

Ditch Witch[®]

AT4020M1

ISSUE NO. 06PL-07/11

For Replacement Copy Order **P/N 053-092**

This product is covered by one or more of the following patents:

US 4,953,638; 5,148,880; 5,242,026; 5,341,887; 5,490,569; 5,684,466; 5,713,423; 5,740,703; 5,758,553; 5,794,719; 5,880,680; 5,941,322; 6,085,852C1; 6,109,371; 6,179,065; 6,216,803; 6,250,403; 6,250,404; 6,290,606; 6,311,790; 6,411,094; 6,543,551; 6,550,547; 6,672,409; 6,739,413; 6,761,231; 6,776,246; 6,808,210; 6,827,158; 6,848,506; 6,871,712; 6,896,077; 7,000,710; 7,011,166; 7,013,990; 7,018,164; 7,025,152; 7,038,454; 7,111,693; 7,150,331; RE37,450; RE37,923; RE37,975; RE38,418

AU 689,533; 706,544; 718,034; 755,862

CA 2,156,398; 2,217,899

FR 674,093

DE 694 17 019; 695 29 634; 697 28 716;

EP 0927892; 1466068

GB 2,312,006; 2,418,553; EP674,093; EP817,901; EP846,841; EP927,892

JP 3,458,247

Other U.S. and foreign patents pending

This manual contains information concerning the following models:
AT/JT4020 Mach 1 Directional Drilling System

Copyright 2004, 2005, 2007, 2011 by The Charles Machine Works, Inc.

 **Ditch Witch**, Ditch Witch, CMW, AutoCrowd, Modularmatic, Jet Trac, Roto Witch, Subsite, Fluid Miser, Perma-Soil, Power Pipe, Super Witch, Super Witch II, Pierce Arrow, The Underground, and The Underground Authority Worldwide are registered trademarks of The Charles Machine Works, Inc.

ID0135016

FOREWORD

This manual contains illustrated parts lists to help you select quality ProTech[®] Replacement parts for your Ditch Witch[®] equipment. Using other replacement parts will lessen the productivity of your equipment.

- ◆ Part numbers enclosed in a box are no longer available from The Charles Machine Works, Inc. Your local Ditch Witch dealer may be able to locate the part for you.
- ◆ Footnotes provide more information to help you identify parts shown in the manual.
- ◆ Assembly instructions and Tech Bits articles referenced in footnotes are available through your local Ditch Witch dealer.
- ◆ Description and specifications in this book were current at publication. However, The Charles Machine Works, Inc. reserves the right to improve equipment, so this manual might not reflect the most current improvements.
- ◆ Instructions on recommended equipment use and maintenance are in the Operator's Manual that was shipped with your equipment.

Keep the following in mind when ordering ProTech replacement parts:

- ◆ Specify parts you need by part number and description, not by illustration reference numbers.
- ◆ Have equipment model and serial number on hand to help ensure you get the right parts for your machine whether it's old or new.

Thank you for buying and using Ditch Witch equipment and ProTech replacement parts.

WARRANTY

DW WARRANTY Policy
July, 2005

POLICY 1: DITCH WITCH® EQUIPMENT AND REPLACEMENT PARTS LIMITED WARRANTY POLICY

Subject to the limitation and exclusions herein, free replacement parts will be provided at any authorized Ditch Witch dealership for any Ditch Witch equipment or parts manufactured by The Charles Machine Works, Inc. (CMW) that fail due to a defect in material or workmanship within one (1) year of first commercial use (Exception: 2 years for all SK500 Attachments). Free labor will be provided at any authorized Ditch Witch dealership for installation of parts under this warranty during the first year following "initial commercial" use of the serial numbered Ditch Witch equipment on which it is installed. The customer is responsible for transporting their equipment to an authorized Ditch Witch dealership for all warranty work.

EXCLUSIONS FROM PRODUCT WARRANTY

- All incidental or consequential damages.
- All defects, damages, or injuries caused by misuse, abuse, improper installation, alteration, neglect, or uses other than those for which products were intended.
- All defects, damages, or injuries caused by improper training, operation, or servicing of products in a manner inconsistent with manufacturer's recommendations.
- All engines and engine accessories (these are covered by original manufacturer's warranty).
- Tires, belts, and other parts which are subject to another manufacturer's warranty. (Such warranty will be available to purchaser.)
- ALL IMPLIED WARRANTIES NOT EXPRESSLY STATED HEREIN, INCLUDING ANY WARRANTY OF FITNESS FOR A PARTICULAR PURPOSE AND MERCHANTABILITY.

IF THE PRODUCTS ARE PURCHASED FOR COMMERCIAL PURPOSES, AS DEFINED BY THE UNIFORM COMMERCIAL CODE, THEN THERE ARE NO WARRANTIES WHICH EXTEND BEYOND THE FACE HEREOF AND THERE ARE NO IMPLIED WARRANTIES OF ANY KIND WHICH EXTEND TO A COMMERCIAL BUYER. ALL OTHER PROVISIONS OF THIS LIMITED WARRANTY APPLY INCLUDING THE DUTIES IMPOSED.

Ditch Witch products have been tested to deliver acceptable performance in most conditions. This does not imply they will deliver acceptable performance in all conditions. Therefore, to assure suitability, products should be operated under anticipated working conditions prior to purchase.

Defects will be determined by an inspection within thirty (30) days of the date of failure of the product or part by CMW or its authorized dealer. CMW will provide the location of its inspection facilities or it's nearest authorized dealer upon inquiry. CMW reserves the right to supply remanufactured replacement parts under this warranty as it deems appropriate.

Extended warranties are available upon request from your local Ditch Witch dealer or CMW.

Some states do not allow exclusion or limitation of incidental or consequential damages, so the above limitation or exclusion may not apply. Further, some states do not allow exclusion of or limitation of how long an implied warranty lasts, so the above limitation may not apply. This limited warranty gives product owner specific legal rights and the product owner may also have other rights which vary from state to state.

For information regarding this limited warranty, contact CMW's Product Support Department, P.O. Box 66, Perry, OK 73077-0066, or contact your local Ditch Witch dealer.

CONTENTS

Decals

Decal Location - AT4020 Mach 1	8
--------------------------------------	---

Engine Components

Air Filter System	30
Covers - Battery	40
Covers - Engine	34
Engine - John Deere Diesel	14
Engine Mounts	20
Engine Oil Drain	28
Engine Skid Edging	24
Engine Skid	22
Fan Clutch	18
Gauge Panel	42
Radiator	32
Sound Insulation	38

Operator's Station

Console	52
Console Gauges	54
Dual Axis Joystick	58
Operator Station	46
Seat - Belts - Cover	50

Track Frame & Main Frame

2-Post ROPS	74
Cylinder Grease	68
Drill Frame - Covers/Locks/Switches	76
Fuel Tank	72
Hose Retaining Clamp	78
Idler	64
Roller	66
Stabilizer - Rear	70
Track Group - Rubber	62

Anchor Systems

Anchor	96
Anchor Drive - Left	92
Anchor Drive - Right	90
Anchor Valve/Cover Mount	84
Auger Anchor Base	82
Flange Hex Driver	94
Front Pipe Guide - (JT4020AT)	86
Front Pipe Guide - (JT4020M1)	88

Lubricator

Applicator	106
Auto-Luber	102
Grease Pump	104
Grease Pump Mounting	100
Selector Valve	108

Drill Frame

Carriage (AT42M1/AT42T2)	118
Carriage (JT42M1/JT42T2)	116

Carriage Chain	120
Clamp Assembly	146
Drill Frame - Covers/Locks/Switches	150
Gearbox - Rotation (JT42M1/JT42T2)	136
Gearbox - Rotation Drive (AT4020) - Begins	128
Gearbox - Rotation Drive (AT4020) - Ends	124
Gearbox - Rotation Drive (JT42M1)	132
Grease Cylinder	152
Hose Track	144
Hydraulic Cylinder (4.5" x 2.25" x 2.75")	154
Outer Spindle Drive Case Drain	142
Pivot	112
Spindle Drive	140
Thrust Drive	114
Thrust Idler	122
Wrench Pipe Guide	148

Pipe Loader System

Gripper Cylinder	168
Guard Lock Pin	180
Pipe Box - (AT Pipe)	174
Pipe Box - (JT Pipe)	176
Pipe Loader Gripper	166
Pipe Loader Lifters	160
Pipe Loader Shuttle - Front	162
Pipe Loader Shuttle - Rear	164
Pipe Loader Shuttle Drive	158
Shuttle Guard	178
Shuttle Stop	170
Shuttle Stop Indicator	172

Fluid System

Antifreeze Tank	200
Fluid Pump - 70 GPM	192
Fluid Pump - 120 GPM	190
Fluid Pump - Power - (L1122 - L1622)	198
Fluid Pump - Power End	194
Mud Pump Plumbing - 70 GPM	186
Mud Pump Plumbing - 120 GPM	184
Mud System Plumbing	188
Pump Mount	196
Wash Wand	202

Hydraulics

2-Speed Track/Thrust	242
Anchor Motor Hydraulics - Left	292
Anchor Motor Hydraulics - Right	290
Anchor Supply Hydraulics	286
Anchor Valve Pressure Return Hydraulics	288
Auxiliary Supply/Return Hydraulics	300
Auxiliary Valve	298
Cylinder - Anchor Thrust - Left	296
Cylinder - Anchor Thrust - Right	294
Frame Tilt Hydraulics	306
Greaser Hydraulics	316

Continued

CONTENTS

Hydraulics Continued

Gripper Hydraulics.....	314
Hydraulic Cylinder - (2x1).....	320
Hydraulic Cylinder - (2x1.25x24).....	322
Hydraulic Cylinder - (3x1.75).....	324
Hydraulic Cylinder - (4x2).....	326
Hydraulic Cylinder - (4x2x10).....	328
Hydraulic Diagram.....	210
Hydraulic Reservoir.....	220
Hydraulic Schematic.....	206
Inner Rotation Control Kit.....	266
Inner Rotation Hydraulics.....	264
Inner Spindle Rotation Gauge - (AT).....	232
Inner/Outer Spindle Drive Case.....	236
Load Sense Hydraulics - Begins.....	258
Load Sense Hydraulics - Ends.....	254
Load Sense Rear Hydraulics.....	262
Main Frame Bulkhead.....	224
Mud Check Supply Hydraulics.....	250
Mud Motor Hydraulics.....	272
Oil Cooler Hydraulics.....	214
Oil Return Hydraulics.....	218
Outer Rotation Hydraulics.....	234
Outer Spindle Drive Case Drain.....	238
Pipe Lifter Hydraulics - (JT4020AT).....	312
Pipe Loader Supply & Return.....	308
Pipe Shuttle Hydraulics.....	310
Remote Filter.....	240
Rotation - Thrust/Mud Gauges.....	222
Rotation Gauge Valve - (JT4020AT).....	228
Rotation Hydraulics.....	226
Rotation Test Ports - (JT4020M1).....	230
Seat Rotation Hydraulics.....	318
Shuttle Stop Hydraulics.....	304
Spindle Brake.....	244
Stabilizer Hydraulics.....	302
Thrust Drive Hydraulics.....	300
Thrust Hydraulics.....	268
Thrust/Track Drive Pump Hydraulics.....	252
Track Brake.....	248
Track Case Drain Hydraulics.....	276
Track Drive Hydraulics.....	274
Track Shift.....	246
Wrench Hydraulics.....	278
Wrench Hydraulics - Front.....	280
Wrench Hydraulics - Rear.....	282
Wrench Hydraulics - Rotate.....	284

Electrical

Alarm/Strobe Light.....	392
Battery.....	384
Dither Assist Harness.....	376
Electrical Diagram - Drill Frame Harness.....	368
Electrical Diagram - Engine.....	342
Electrical Diagram - Gauge (AT/JT).....	348
Electrical Diagram - Main Frame.....	364

Electrical Diagram - Operator Station.....	354
Electrical Diagram - Pullback Stop Harness.....	374
Electrical Diagram - Relay (AT/JT).....	346
Electrical Diagram - Rotation Harness.....	378
Electrical Diagram - Switch Jumper (JT4020AT) ...	352
Electrical Diagram - Water Temp Gauge -Ends	350
Electrical Diagram - Work Light.....	366
Electrical Schematic (JT4020AT).....	332
Electrical Strike System.....	380
Engine Ground.....	390
Left Console Relay Panel.....	388
Load Sense Valve Harness.....	394
Relay Panel (JT4020AT).....	386
Right Console.....	382

Accessories

Cold Start.....	398
Drilling Fluid Transfer.....	400
Grounding Hardware (ESS).....	408
Heated Hose Kit.....	404
Mud Mixing Accessories.....	402
Tool Box.....	412
Vandal Covers.....	410
Working Light.....	406

Miscellaneous

Bolt/Nut Torque Chart.....	416
Filters.....	420
Optional Kits.....	420
Parts Manual Change Request.....	421
Related Publications.....	420
Replacement O-Ring Chart.....	419
Warranty Registration.....	424

DECALS

DECAL LOCATION JT4020AT

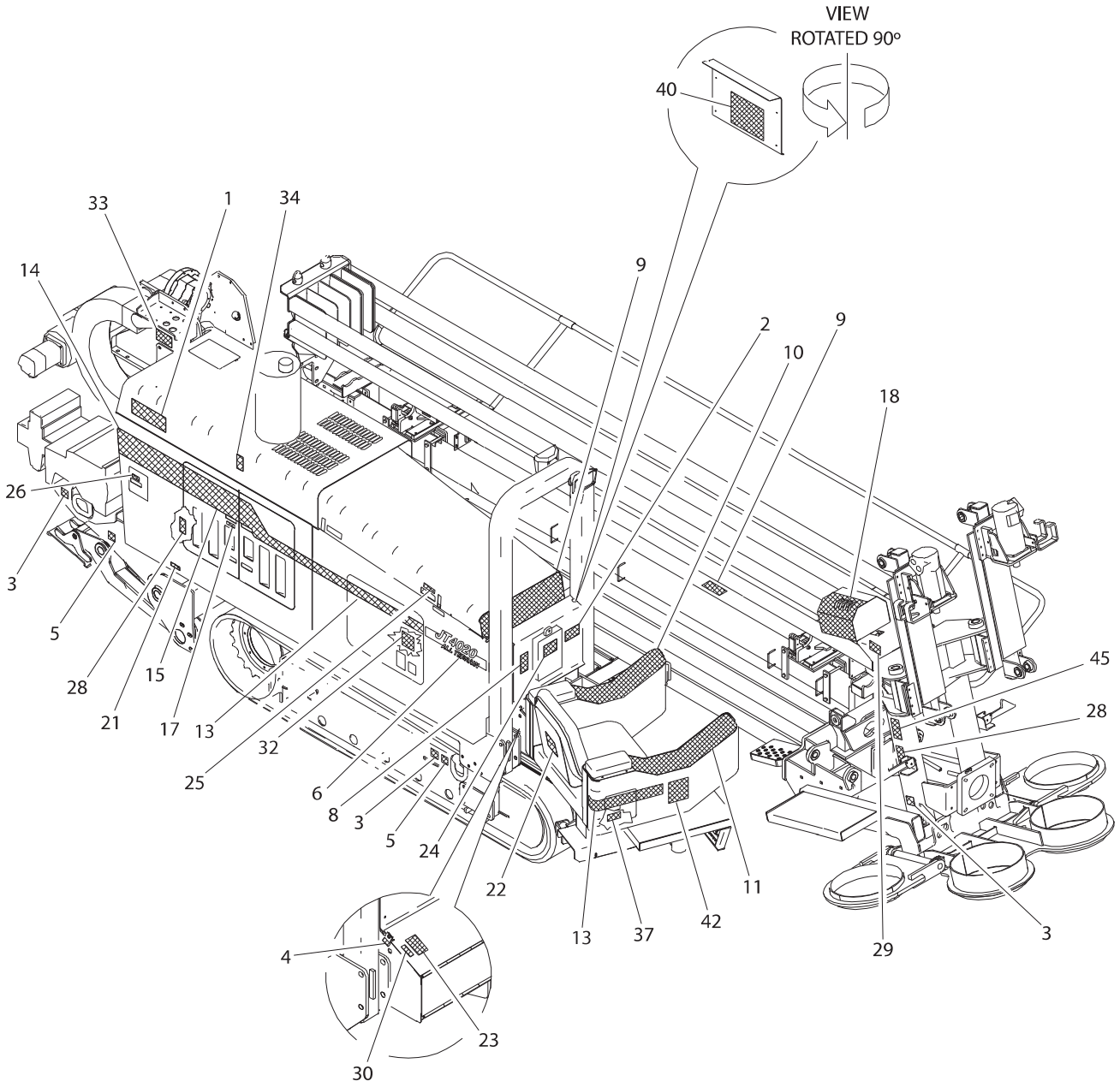

DECAL LOCATION JT4020AT

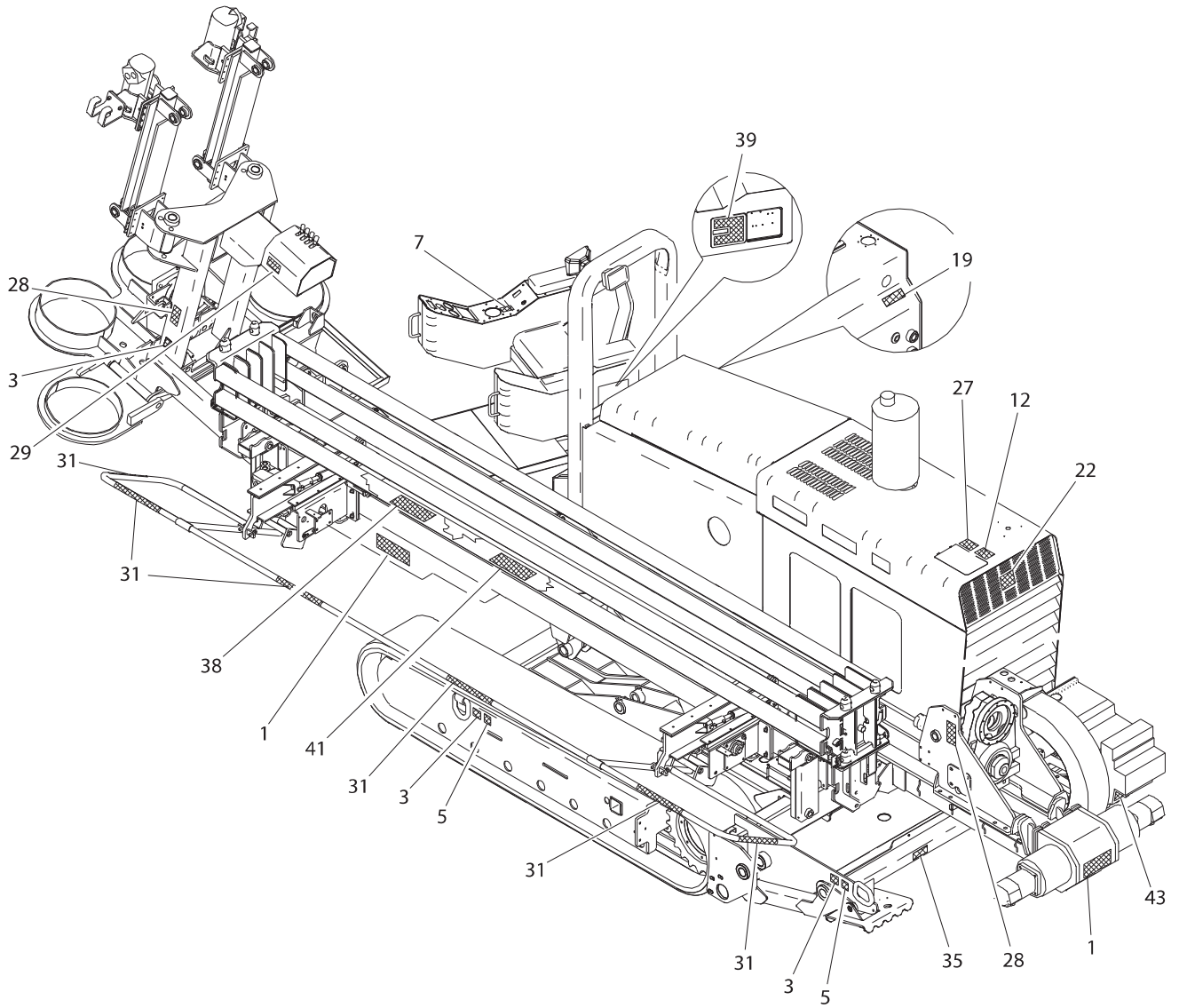

DECAL LOCATION JT4020AT

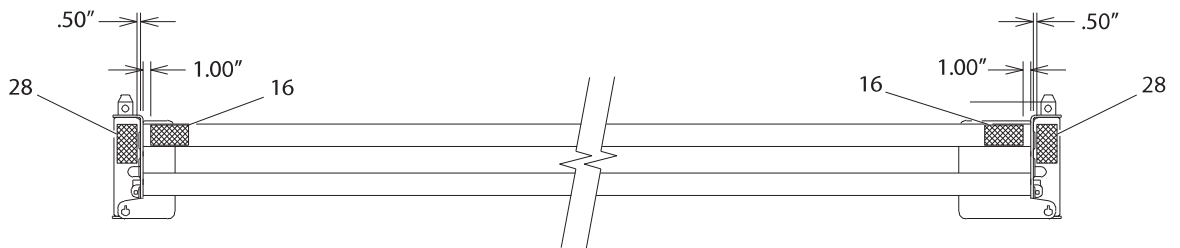
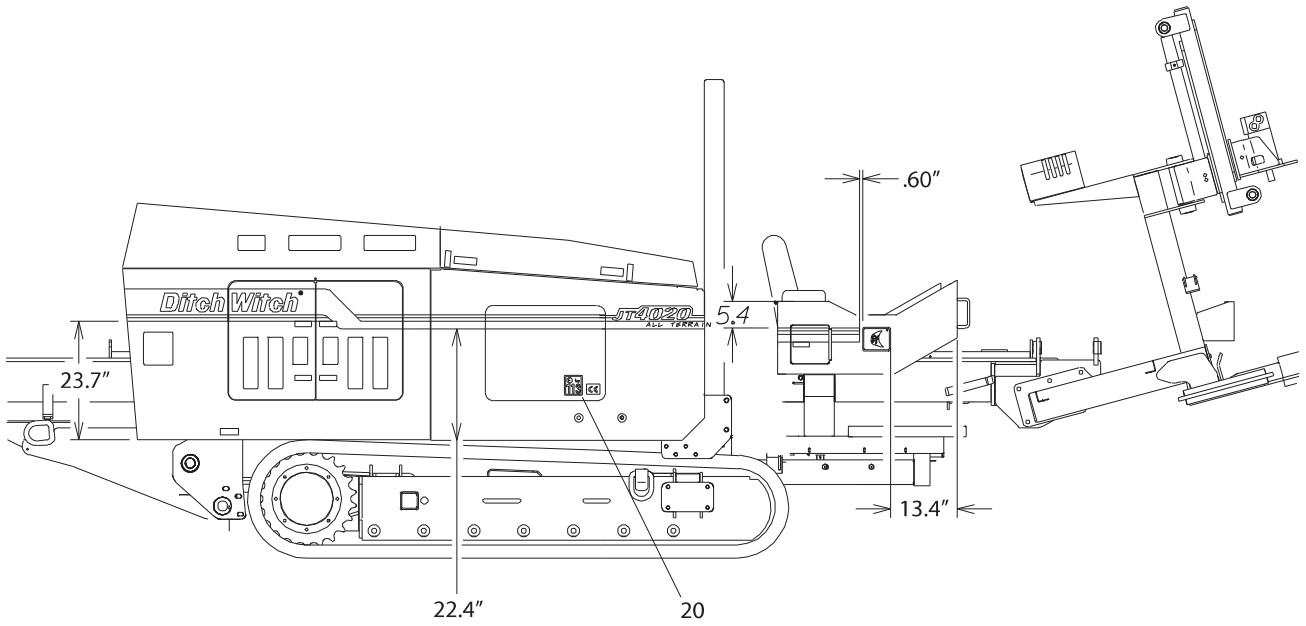

DECAL LOCATION JT4020AT

REF NO.	PART NUMBER	QTY	DESCRIPTION	REMARKS
	275-879		DECAL KIT - 4020AT	
I	274-049	3	DANGER ELECTROCUTION	8 PER TRAFFIC CONES
2	274-050	I	WARNING JOBSITE HAZARD	
3	274-318	6	TIE DOWN LOCATION	
4	274-375	I	MASTER DISCONNECT SWITCH	
5	274-442	4	LIFT LOCATION	
6	273-269	I	JT40AT MODEL -ID	
7	274-724	I	ONE CALL NOTIFICATION	
8	274-780	I	JET TRAC PATENT (S)	
9	700-070	I	JT4020 INSTRUMENT PANEL	
10	700-060	I	JT40AT LEFT CONSOLE	
II	273-218	I	IGNITION - JOYSTICK - GAUGE	
12	273-138	I	NOTICE COOLANT	
13	274-877	AR	GRAPHIC STRIPE	USE I @ 80"
14	274-883	I	DITCH GRAPHIC STRIPE	
15	274-884	I	WITCH GRAPHIC STRIPE	
16	275-326	24	WARNING CRUSHING WEIGHT	4 PER PIPEBOX
17	275-400	I	NOTICE OIL LEVEL	
18	273-181	I	ANCHOR ROTATION-THRUST	
19	274-198	I	NOTICE OIL LEVEL	
20	273-016	I	SOUND POWER II	SEE FOOTNOTE I
21	275-497	I	OIL DRAIN ID	
22	275-449	2	DITCH WITCH LOGO PLACARD	
23	275-033	I	NOTICE ELECTRICAL SYSTEM	
24	275-048	I	IMPORTANT SAFETY RULES	
25	275-120	I	RESERVOIR (THF)	
26	275-148	I	FUEL TANK DIESEL	
27	273-146	I	NOTICE ADD COOLANT	
28	275-184	28	WARNING MOVING PARTS	
29	275-197	2	DANGER ROTATING SHAFT	4 PER PIPEBOX
30	275-203	I	BATTERY	
31	275-230	6	WARNING STRIPE (1.75" X 18")	
32	273-275	I	AT/JT INNER SPINDLE	
33	275-341	I	WARNING SLIDING PARTS	
34	275-355	I	CAUTION HOT PARTS	
35	275-372	I	IMPORTANT CYLINDER LOCK	
36	273-227	I	SHUTTLE STOP INDICATOR	
37	273-198	I	TRACKER CONTROL	
38	273-233	I	FRONT WRENCH VALVE	
39	273-120	I	LEFT RELAY PANEL	
40	273-119	I	RELAY PANEL	
41	273-384	I	PIPELOADER VALVE	
42	275-307	I	DITCH WITCH EMBLEM	
43	700-061	I	WASH WAND	
44	273-267	I	DITCH WITCH BATTERY	SEE FOOTNOTE 2
45	273-278	I	DANGER WRENCH	

FOOTNOTES

1. NOT PART OF KIT. FOR EUROPEAN UNITS ONLY.
2. LOCATE DECAL ON BATTERY SO THAT DECAL IS VISIBLE WHEN VIEWING BATTERY.

ENGINE COMPONENTS

ENGINE AT42M1

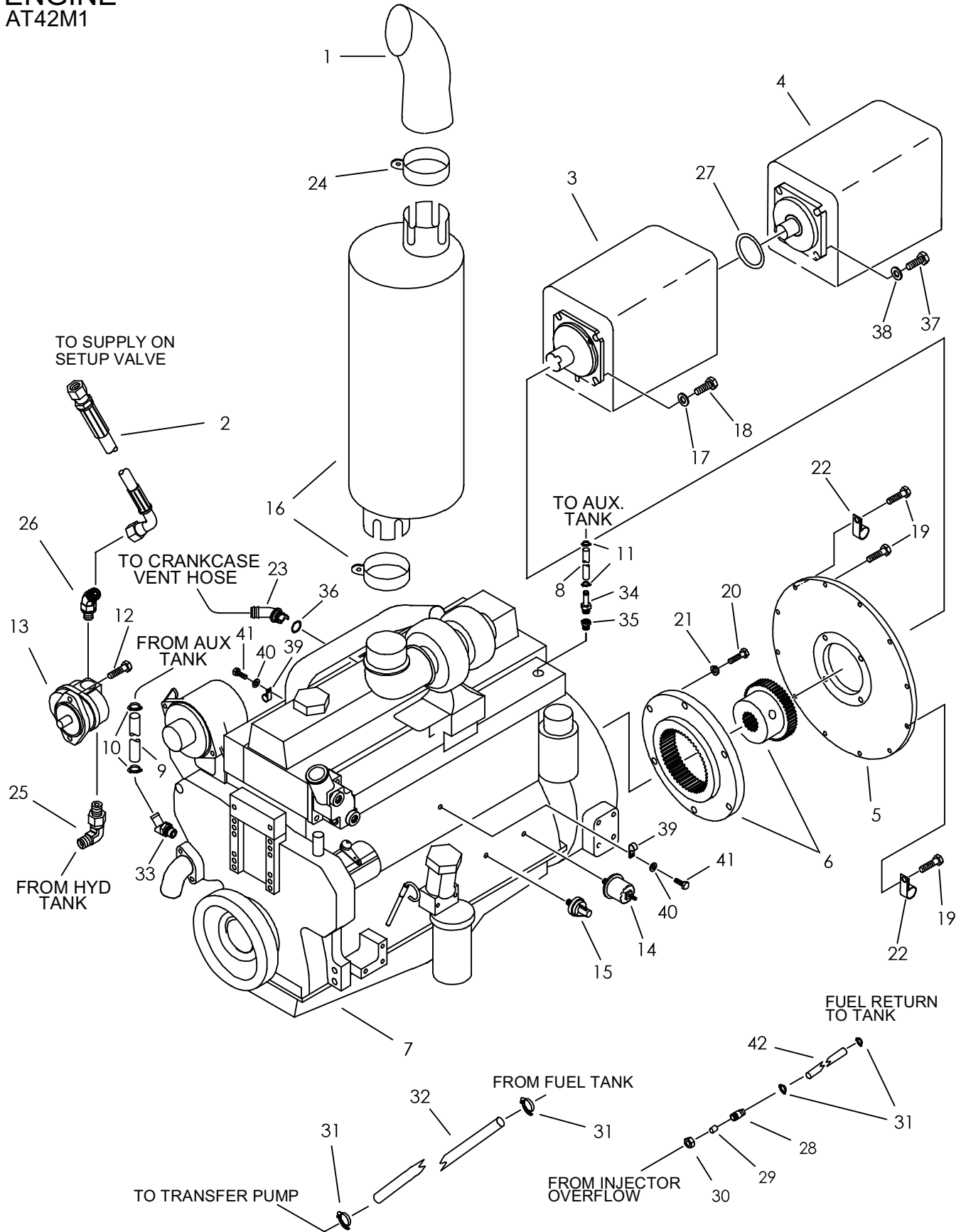

ENGINE AT42M1

REF NO.	PART NUMBER	QTY	DESCRIPTION	REMARKS
1.	196-373	1	EXTENSION TUBE (3" OD X 12")	
2.	154-955	-	HOSE (080FX90-102"-3000)	
3.	153-340	1	HYDRAULIC PUMP	SEE FOOTNOTE 3
	149-939	1	FILTER ELEMENT	
4.	150-2180	1	HYDRAULIC PUMP LS	
	190-1371	-	PUMP SEAL KIT	
5.	336-051	1	FLY WHEEL HOUSING COVER	
6.	160-897	1	DRIVE COUPLING	SEE FOOTNOTE 1
7.	194-083	1	ENGINE - DEERE DIESEL	
	194-823	-	THERMOSTAT	
	165-883	-	GASKET, THERMOSTAT	
	194-815	-	OIL FILTER ELEMENT	
	194-816	-	FUEL FILTER ELEMENT	
	217-451	-	ALTERNATOR (95 AMP)	
	211-022	-	STARTER	
	170-373	-	FAN BELT	
	194-159	-	PUMP, ENGINE COOLANT	
	168-617	-	GASKET, WATER PUMP	
8.	116-108	AR	BULK HOSE (5/16", SOLD PER 1")	USE 1 @ 52"
9.	116-750	AR	BULK HOSE (5/8", SOLD PER 1")	USE 1 @ 28"
10.	110-026	2	WORM CLAMP (1/2" TO 1-1/4")	
11.	110-249	2	WORM CLAMP (1/4" TO 1")	
12.	106-079	2	SCREW (M10-1.50 X 30mm)	
13.	149-838	1	HYDRAULIC PUMP	SEE FOOTNOTE 2
	500-966	-	SEAL REPAIR KIT	
14.	215-183	1	SENDER, OIL PRESSURE HD	USE 567 LOCTITE PIPE SEALANT
15.	217-736	1	OIL PRESSURE SWITCH	USE 567 LOCTITE PIPE SEALANT
16.	196-372	1	MUFFLER OUTLINE	
	194-027	-	MUFFLER CLAMP (4.143")	
17.	105-244	4	WASHER (1/2")	
18.	105-048	4	BOLT (1/2-NC X 1-1/2")	USE 242 LOCTITE
19.	106-383	12	FLG LK SCREW (M10-1.50 X 30mm)	USE 242 LOCTITE
20.	105-156	8	BOLT (3/8-NC X 1-1/2")	USE 242 LOCTITE, TORQUE TO 30 FT LBS

NOT SHOWN:

FOOTNOTES:

- TORQUE CROSSBOLT TO 85-90 FT LB; MOUNT FLUSH WITH END OF SHAFT
- RE-INSTALL GASKET FROM COVER PLATE.
- ON THE BACK OF THE PUMP OF SOME EARLY MACHINES A DIFFERENT MOUNT PAD WAS USED. IF THE BOLTS HOLDING THE PAD TO THE PUMP HAVE A WASHER UNDER THE BOLT HEAD USE O-RING 157-201 BETWEEN THE PUMPS.

NOTE:

ENGINE AT42M1

REF NO.	PART NUMBER	QTY	DESCRIPTION	REMARKS
21.	105-072	8	LOCK WASHER (3/8")	
22.	110-259	1	BOLT-ON CLAMP (.625")	
23.	153-161	1	ELBOW (-12H45, SPECIAL)	
24.	194-049	1	MUFFLER CLAMP	
25.	154-286	1	CONNECTOR (120-16S90)	
26.	154-264	1	CONNECTOR (080-10S45)	
27.	157-084	-	O-RING (159 D70)	
28.	156-275	1	TUBE CONNECTOR (04H-05T)	
29.	156-276	1	FERRULE (05T)	
30.	156-277	1	COMPRESSION NUT (05T)	
31.	110-528	4	SNAP-ON CLAMP (.531" TO .593")	
32.	116-108	AR	BULK HOSE (5/16", SOLD PER 1")	USE 1 @ 68.0"
33.	153-160	1	S/O COUPER (18M-10H45)	REMOVE PLUG AND INSTALL ELBOW IN WATER PUMP
34.	155-162	1	S/O COUPLER (04N-05H)	USE 567 LOCTITE PIPE SEALANT
35.	115-286	1	REDUCER (08N-1/4-NF)	USE 567 LOCTITE PIPE SEALANT
36.	157-050	1	O-RING (116 D70)	
37.	105-302	2	BOLT (5/8-NC X 2", GD8)	LOCTITE 242
38.	106-398	2	WASHER (M16, HARDENED)	
39.	110-259	2	BOLT-ON CLAMP (.625")	
40.	105-118	2	WASHER (3/8")	
41.	105-245	2	SCREW (M10-1.50 X 25MM)	
42.	116-108	AR	BULK HOSE (5/16", SOLD PER 1")	USE 1 @ 78.0"

NOT SHOWN:

FOOTNOTES:

NOTE:

REFER TO O-RING CHART (800-301) IN BACK OF THE BOOK FOR REPLACEMENT OF O-RINGS.

FAN CLUTCH

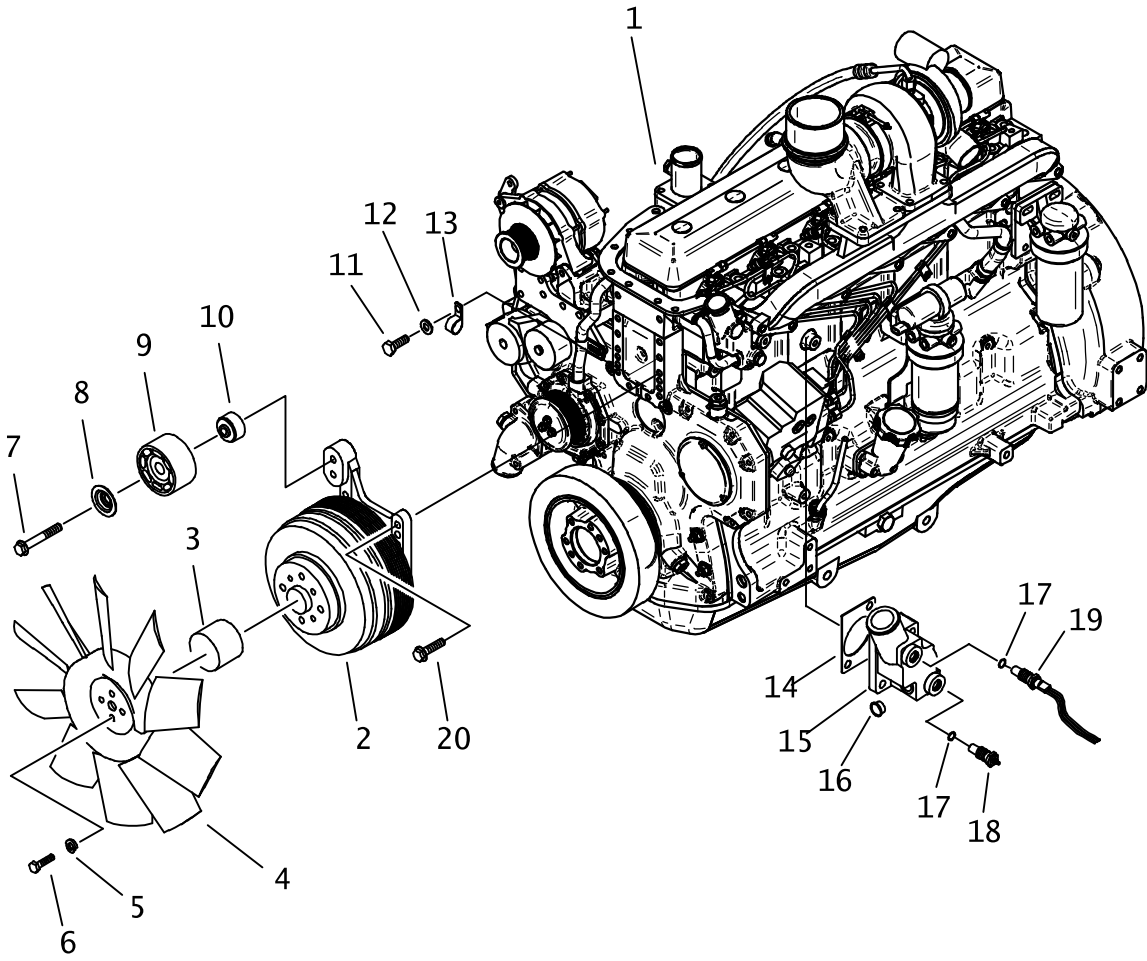

FAN CLUTCH

REF NO.	PART NUMBER	QTY	DESCRIPTION	REMARKS
1.	194-083	-	ENGINE - DEERE DIESEL	
2.	194-298	1	FAN DRIVE	
3.	184-404	2	COOLING FAN SPACER	
4.	194-134	1	FAN (26.0" OD, 2.50" BC)	
5.	105-091	4	LOCK WASHER (5/16")	
6.	106-160	4	FLG LK SCREW (M8-1.25 X 120MM)	
7.	106-998	1	FLG LK SCREW (M10-1.50 X 70MM)	
8.	179-461	1	SLEEVE	
9.	170-379	1	IDLER PULLEY	
10.	179-462	1	SPACER	
11.	105-245	1	SCREW (M10-1.50 X 25MM)	
12.	106-390	1	WASHER (M10)	
13.	110-126	1	BOLT-ON CLAMP (1/2")	
14.	165-883	1	GASKET, THERMOSTAT	
15.	164-027	1	THERMOSTAT HOUSING	
16.	153-993	1	GASKET, THERMOSTAT TUBE	
17.	155-705	2	O-RING (906 D90)	
18.	217-550	1	WATER TEMPERATURE SENDER	
19.	214-895	1	TEMPERATURE SWITCH	
20.	106-497	4	FLG SCREW (M10-1.50 X 35MM)	

NOT SHOWN:

FOOTNOTES:

1. FAN MUST BE CENTERED IN DIAMETER OF RADIATOR SHROUD OPENING, INSTALL WITH NOTCHES TOWARD RADIATOR.
2. REMOVE O-RING FROM PLUG AND INSTALL ON WATER TEMPERATURE SENDER WHEN ASSEMBLING.

NOTE:

ENGINE MOUNTS

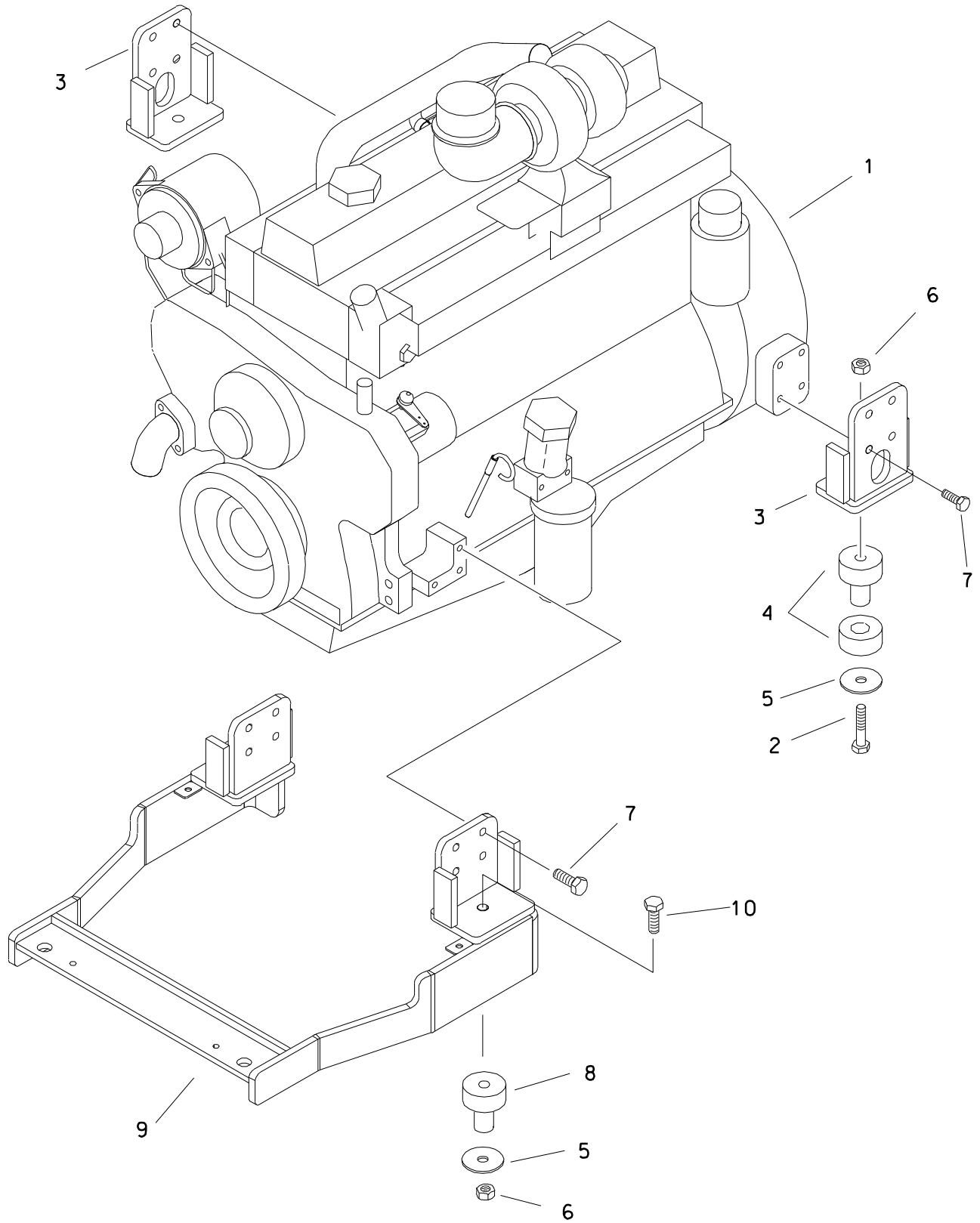

ENGINE MOUNTS

REF NO.	PART NUMBER	QTY	DESCRIPTION	REMARKS
1.	194-083	-	ENGINE - DEERE DIESEL	
2.	106-343	2	SCREW (M16-2.0 X 110mm)	
3.	354-325	2	REAR ENGINE MOUNT	
4.	116-127	2	SHOCK MOUNT	
5.	105-416	4	WASHER (5/8")	
6.	106-545	4	LOCKNUT (M16-2.00, PRV TRQ, 10.9)	
7.	105-247	14	SCREW (M12-1.75 X 35mm)	USE 242 LOCTITE
8.	116-726	2	SHOCK MOUNT	
9.	350-506	1	FRONT ENGINE MOUNT	
10.	106-342	2	SCREW (M16-2.0 X 90mm)	

FOOTNOTES

ENGINE SKID

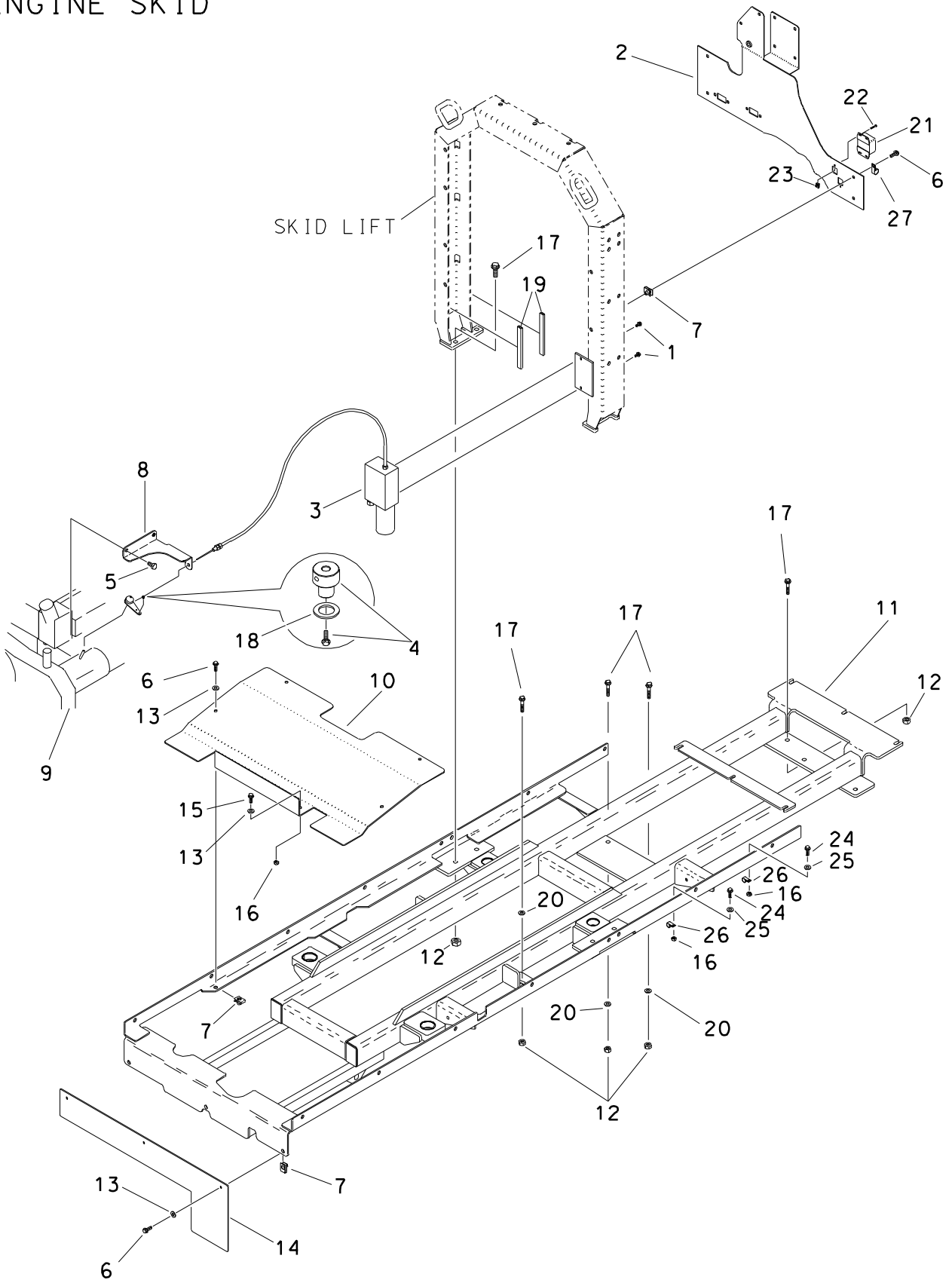

ENGINE SKID

REF NO.	PART NUMBER	QTY	DESCRIPTION	REMARKS
1.	105-836	2	FLG LOCK BOLT (1/4-NC X 1/2 ")	
2.	303-705	-	FIREWALL	
3.	215-231	1	LINEAR ACTUATOR	SEE FOOTNOTE 1
4.	196-058	1	CABLE SWIVEL (.081")	
5.	105-245	2	SCREW (M10-1.50 X 25mm)	
6.	106-991	11	FLG LK SCREW (M8-1.25 X 20mm)	
7.	106-551	44	CLIP NUT (M8-1.25)	
8.	354-952	1	BRACKET	
9.	194-083	-	ENGINE - DEERE DIESEL	
10.	350-415	1	DEFLECTOR FLAP	
11.	318-500	1	ENGINE SKID	
12.	106-685	13	LOCKNUT (M12-1.75, PRV TRQ, 10.9)	
13.	105-118	9	WASHER (3/8")	
14.	350-410	1	DEFLECTOR FLAP	
15.	106-381	2	FLG LK SCREW (M8-1.25 X 25mm)	
16.	106-561	4	LOCKNUT (M8-1.25, PRV TRQ, 10.9)	
17.	106-632	13	FLG LK SCR (M12-1.75 X 35MM, SER)	
18.	106-205	1	WASHER (.191")	
19.	115-686	AR	BULK EDGE (5/32", SOLD PER 1")	USE 2 @ 5.0"
20.	106-391	4	WASHER (M12)	USED ON SLOTTED HOLES
21.	211-017	1	12V-5V VOLTAGE CONVERTOR	
22.	107-268	2	SCREW (M4-0.70 X 20MM, SOC)	
23.	107-516	2	CLIP NUT (M4-.7)	
24.	106-162	2	FLG SCREW (M8-1.25 X 20MM)	
25.	105-118	2	WASHER (3/8")	
26.	110-333	2	BOLT-ON CLAMP (1")	
27.	211-041	1	CONNECTOR CLIP	

FOOTNOTES

1. REMOVE MOUNTING PLATE AND MOUNT USING TWO 1/4" BOLTS THAT COME WITH LINEAR ACTUATOR

ENGINE SKID EDGING

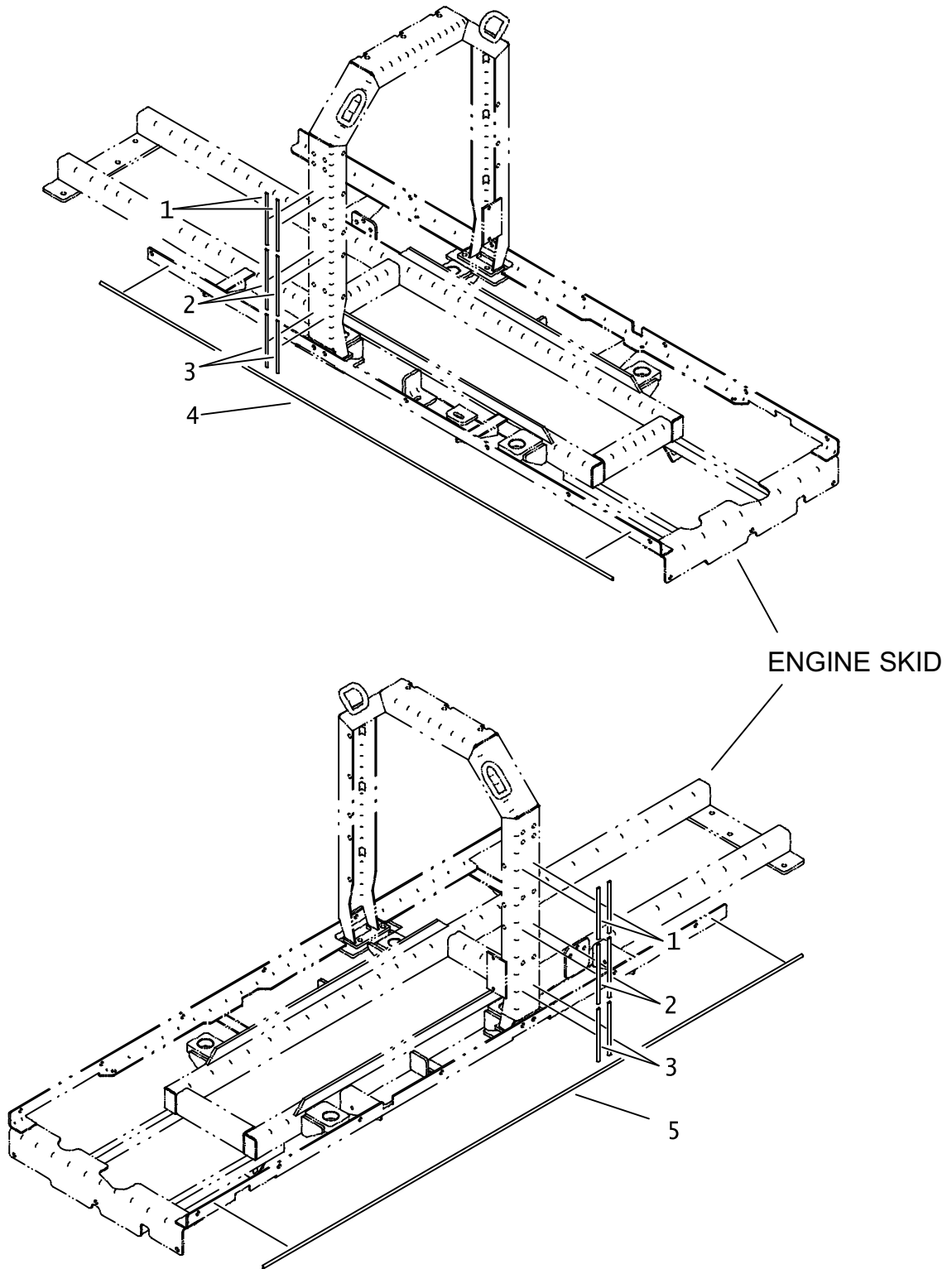

ENGINE SKID EDGING

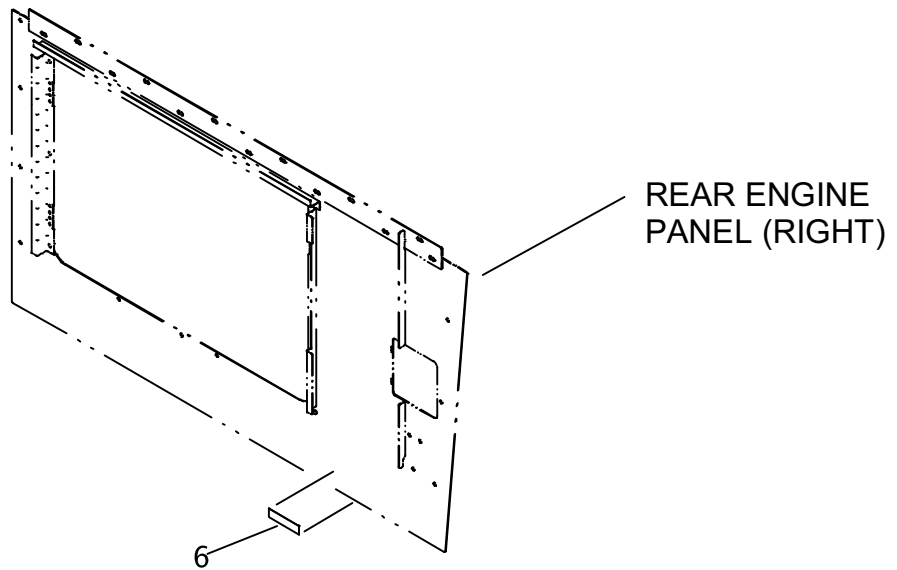
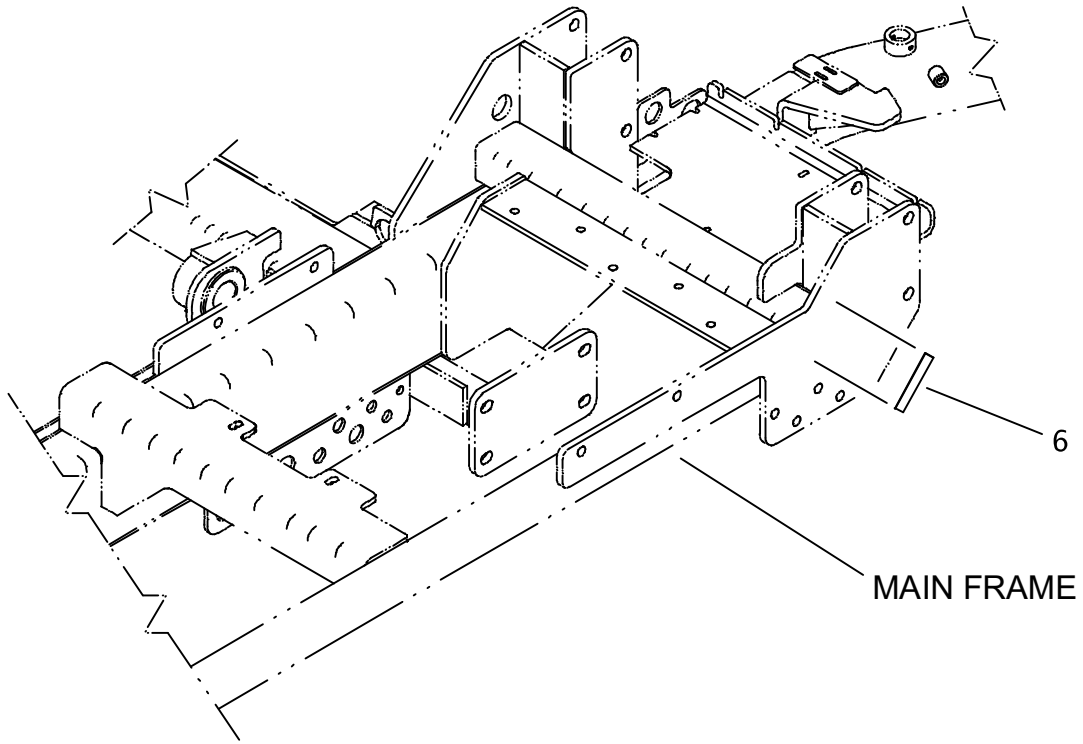

ENGINE SKID EDGING

REF NO.	PART NUMBER	QTY	DESCRIPTION	REMARKS
1.	116-724	AR	BULK SEAL (3/32", SOLD PER 1')	USE 4 @ 7.2"
2.	116-724	AR	BULK SEAL (3/32", SOLD PER 1')	USE 4 @ 8.4"
3.	116-724	AR	BULK SEAL (3/32", SOLD PER 1')	USE 4 @ 7.4"
4.	116-724	AR	BULK SEAL (3/32", SOLD PER 1')	USE 1 @ 83.8"
5.	116-724	AR	BULK SEAL (3/32", SOLD PER 1')	USE 1 @ 88.2"
6.	391-322	AR	.040 X 1.0" UHMW-PE ADHES BACK	USE 8 @ 4"

NOT SHOWN:

FOOTNOTES:

NOTE:

ENGINE OIL DRAIN

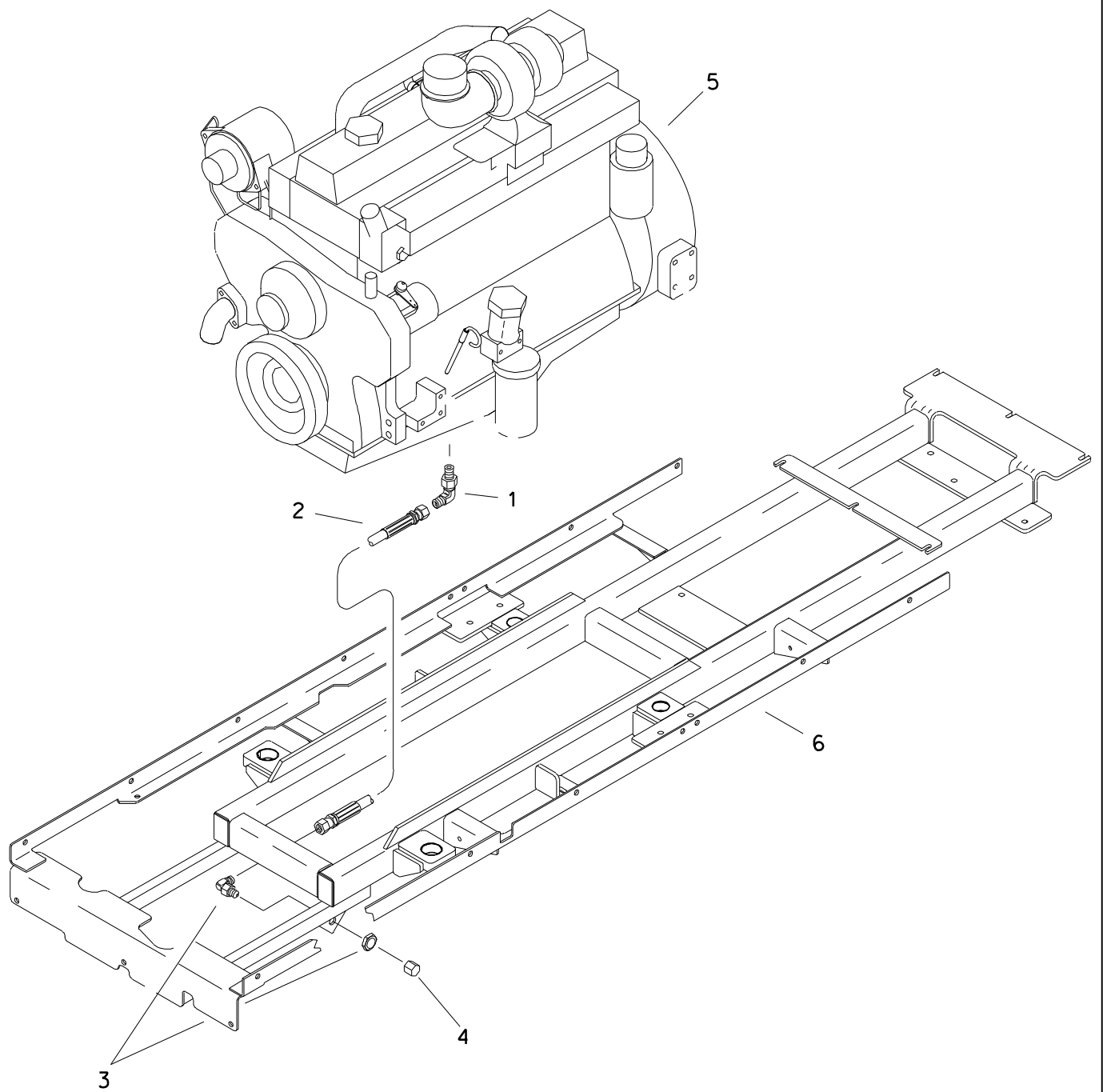

ENGINE OIL DRAIN

REF NO.	PART NUMBER	QTY	DESCRIPTION	REMARKS
1.	154-467	1	CONNECTOR (M18-1.50-08J90)	
2.	154-576	1	HOSE (08JFX-22.5"-2000)	
3.	154-148	1	BK CONNECTOR (08J-08J90BK)	
4.	154-089	1	CAP (08JF)	
5.	194-083	-	ENGINE - DEERE DIESEL	
6.	354-597	-	ENGINE SKID	USED WITH JT4020
	318-500	-	ENGINE SKID	USED WITH AT42M1

FOOTNOTES

NOTE:
REFER TO O-RING CHART (800-301) IN BACK OF THE BOOK FOR REPLACEMENT OF O-RINGS.

AIR FILTER SYSTEM

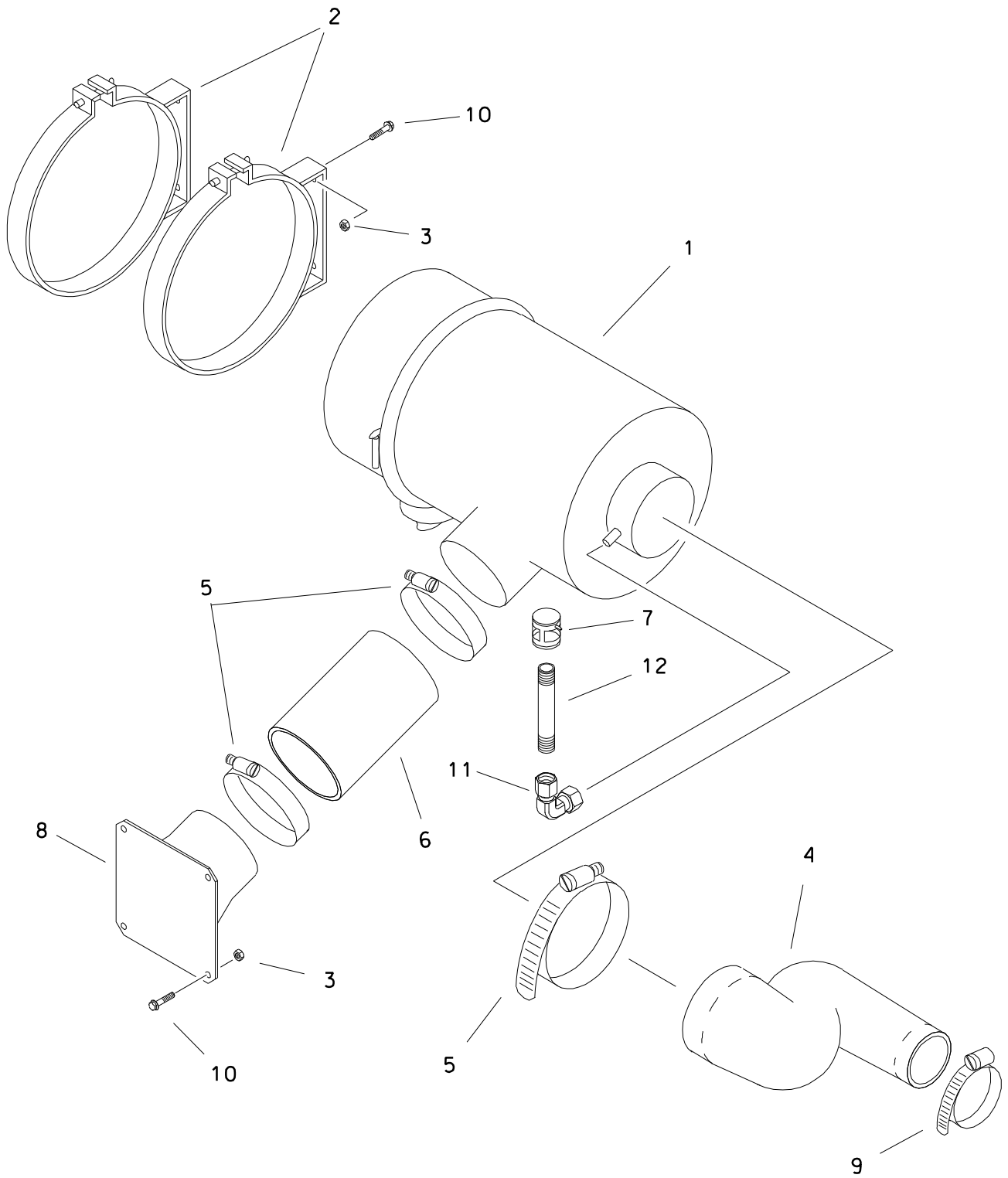

AIR FILTER SYSTEM

REF NO.	PART NUMBER	QTY	DESCRIPTION	REMARKS
1.	159-373	1	AIR FILTER	
	194-827	1	PRIMARY AIR FILTER ELEMENT	
	194-828	1	SECONDARY AIR FILTER ELEMENT	
2.	196-349	2	MOUNTING CLAMP (11.810")	
3.	106-561	8	LOCKNUT (M8-1.25, PRV TRQ, 10.9)	
4.	116-725	1	INTAKE HOSE (3" X 5")	
5.	110-391	3	WORM CLAMP (4-3/4" TO 5-5/8")	
6.	117-616	1	INTAKE HOSE (5" X 12")	
7.	194-788	1	RESTRICTION INDICATOR (25", H2O)	
8.	350-615	1	AIR INTAKE (5")	
9.	110-367	1	WORM CLAMP (3-1/4" TO 4-1/8")	
10.	106-162	8	FLG SCREW (M8-1.25 X 20MM)	
11.	156-228	1	ELBOW (O2NF-O2NF90)	
12.	115-188	1	NIPPLE (O2N-4.250")	

FOOTNOTES

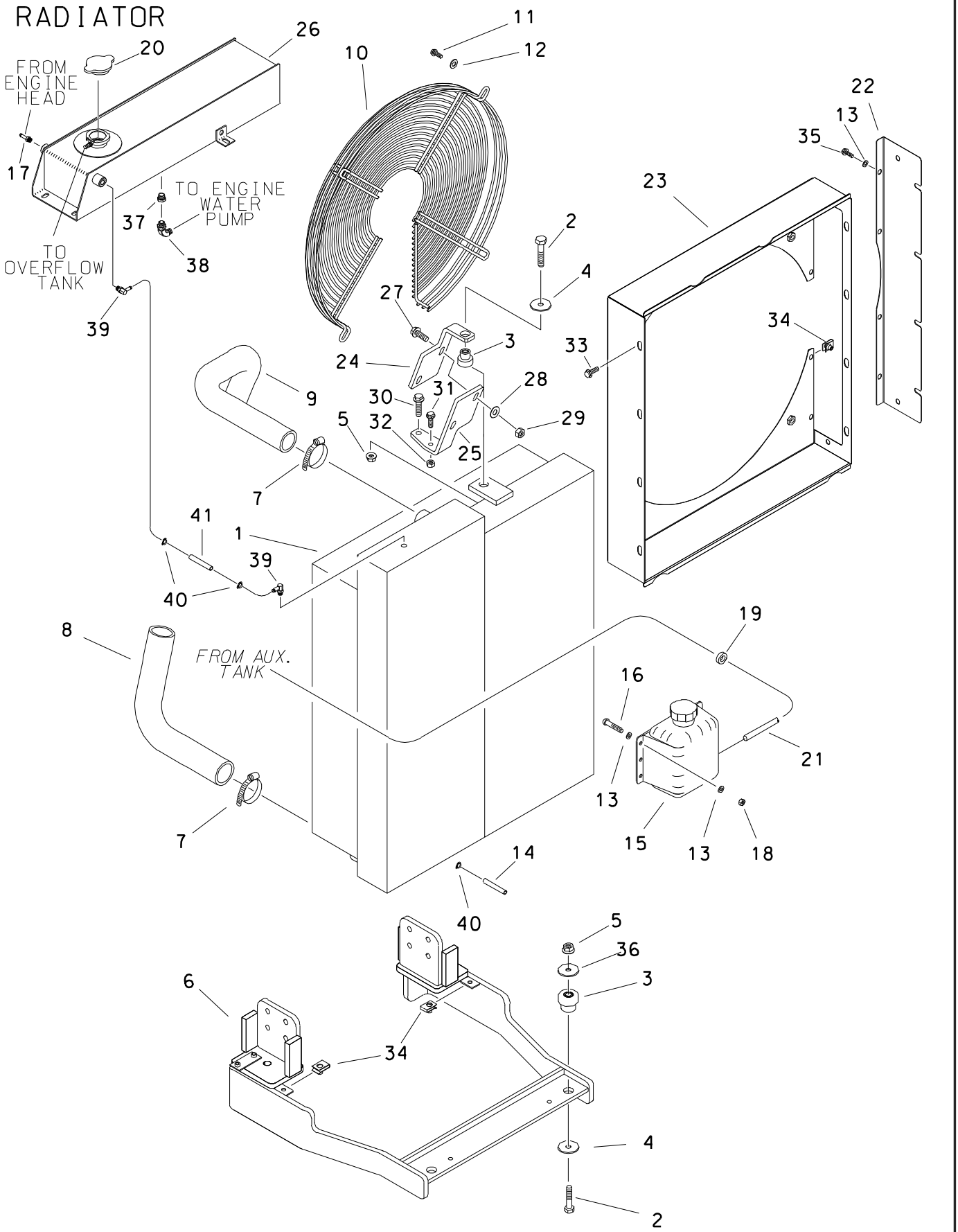

RADIATOR

REF NO.	PART NUMBER	QTY	DESCRIPTION	REMARKS
1.	194-085	1	RADIATOR	SEE FOOTNOTE 1
	111-084	1	RADIATOR CAP (16PSI)	
2.	106-142	3	SCREW (M10-1.50 X 65mm)	
3.	117-906	3	SHOCK MOUNT (70D)	
4.	105-223	3	WASHER (3/8")	
5.	106-387	3	FLG LOCKNUT (M10-1.50)	
6.	350-506	-	FRONT ENGINE MOUNT	
7.	110-134	4	WORM CLAMP (2.062" TO 2.750")	
8.	116-706	1	LOWER COOLANT HOSE	
9.	116-705	1	UPPER COOLANT HOSE	
10.	195-030	1	FAN GUARD (27")	
11.	106-162	4	FLG SCREW (M8-1.25 X 20MM)	
12.	105-118	4	WASHER (3/8")	
13.	105-117	14	WASHER (5/16")	SEE FOOTNOTE 2
14.	116-458	AR	BULK TUBING (3/8", SOLD PER 1")	USE 1 @ 48"
15.	364-229	1	OVERFLOW TANK (3 QUART)	
	110-765	-	CAP (2-1/4")	
	190-053	-	POLY-PATCH TANK REPAIR KIT	
16.	107-334	2	SCREW (M8-1.25 X 25MM, BUT SOC)	
17.	155-162	1	S/O COUPLER (04N-05H)	
18.	106-561	2	LOCKNUT (M8-1.25, PRV TRQ, 10.9)	
19.	115-349	1	GROMMET (1/2")	SEE FOOTNOTE 1
20.	111-084	1	RADIATOR CAP (16 PSI)	
21.	115-381	AR	BULK TUBING (1/4", SOLD PER 1")	USE 1 @ 39"
22.	318-532	1	SHROUD COVER	
23.	318-531	1	FAN SHROUD	
24.	305-809	1	TOP RADIATOR BRACKET (UPPER)	
25.	305-808	1	TOP RADIATOR BRACKET (LOWER)	
26.	309-868	1	EXPANSION TANK	
27.	107-565	2	FLG LK SCREW (M12-1.75 X 40MM)	
28.	106-391	2	WASHER (M12)	
29.	106-685	2	LOCKNUT (M12-1.75, PRV TRQ, 10.9)	
30.	107-004	1	FLG LK SCREW (M12-1.75 X 45MM)	
31.	106-383	1	FLG LK SCREW (M10-1.50 X 30MM)	
32.	105-894	1	LOCKNUT (M10-1.50, PRV TRQ, 10.9)	
33.	105-826	8	FLG LOCK BOLT (3/8-NC X 1")	
34.	106-551	8	CLIP NUT (M8-1.25)	
35.	106-991	6	FLG LK SCREW (M8-1.25 X 20MM)	
36.	106-622	2	WASHER (3/8")	
37.	155-202	1	REDUCER (12N-08NF)	USE LOCTITE 567 PIPE SEALANT
38.	514-285	1	S/O COUPLER (08N-10H90)	USE LICTITE 567 PIPE SEALANT
39.	155-164	2	S/O COUPLER (04N-05H90)	
40.	110-249	3	WORM CLAMP (1/4" TO 5/8")	
41.	116-108	AR	BULK HOSE (5/16", SOLD PER 1")	USE 1 @ 4.0"

FOOTNOTES

- FAN MUST BE CENTERED IN DIAMETER OF RADIATOR SHROUD OPENING. ROUTE OVERFLOW HOSE THROUGH HOLE AND GROMMET (115-349) IN TOP HOOD.
- ONE OF THESE WASHER (106-916) SHOULD BE PLACED BETWEEN NUT (106-561) AND OVERFLOW TANK (364-229), TWO PLACES. ONE OF THE WASHERS SHOULD BE PLACED BETWEEN OVERFLOW TANK AND HOOD STIFFENER PLATE, TWO PLACES.

ENGINE COVERS

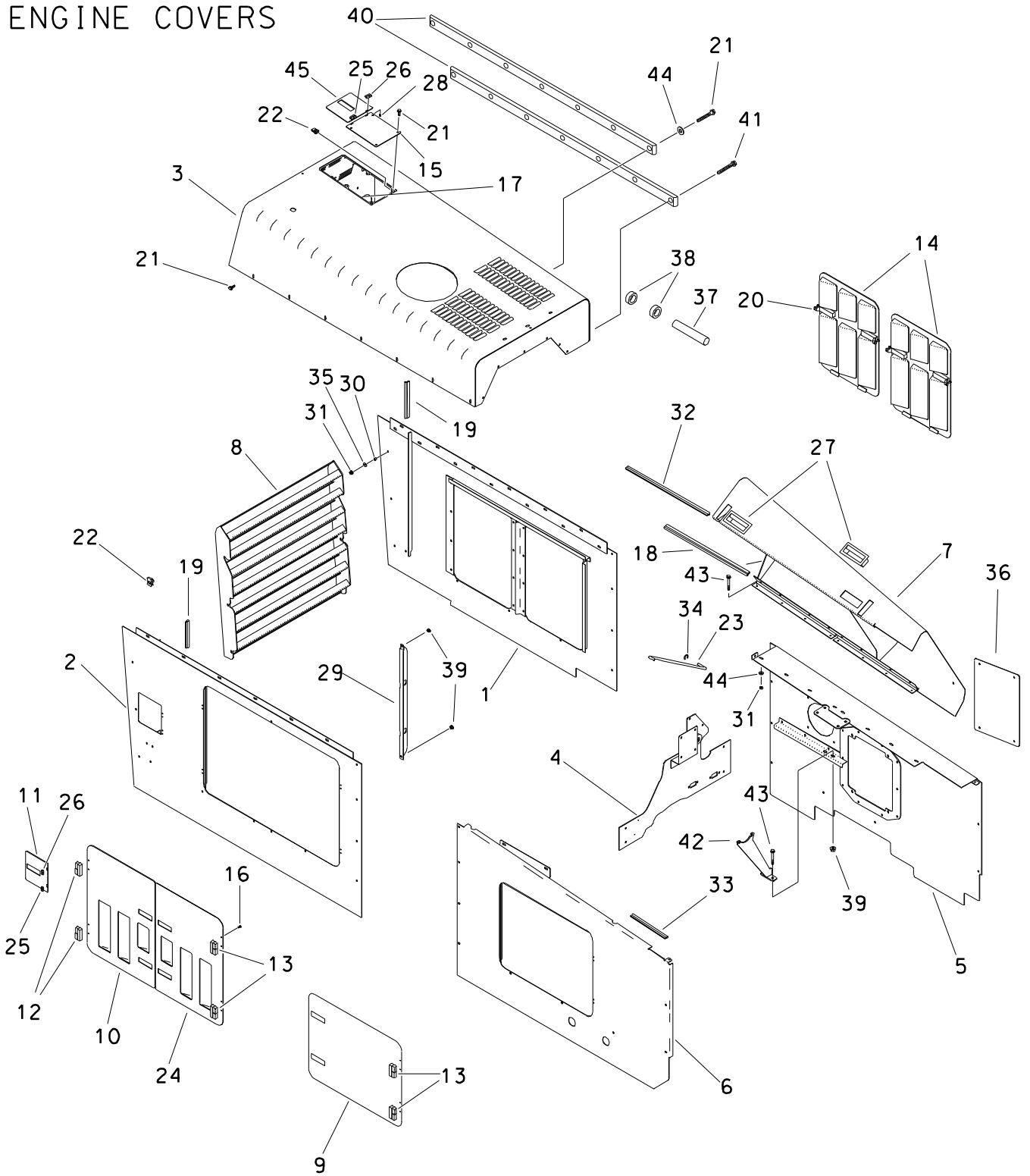

ENGINE COVERS

REF NO.	PART NUMBER	QTY	DESCRIPTION	REMARKS
1.	309-463	1	REAR ENGINE PANEL (LEFT)	
2.	309-462	1	REAR ENGINE PANEL (RIGHT)	
3.	309-236	1	ENGINE PANEL (TOP)	
4.	303-705	1	FIREWALL	
5.	310-452	1	FRONT ENGINE PANEL (LEFT)	
6.	310-448	1	FRONT ENGINE PANEL (RIGHT)	
7.	350-611	1	FRONT HOOD	
8.	354-564	1	GRILLE	
9.	354-579	1	DOOR PANEL	
10.	350-419	1	LEFT DOOR	
11.	354-581	1	DOOR PANEL	
12.	111-002	2	LIFT-OFF HINGE (OFF-SET)	
13.	105-617	4	LIFT-OFF HINGE (OFF-SET)	
14.	350-412	2	LEFT DOOR	
15.	309-243	1	PLATE	
16.	106-228	24	SCREW (M5-.80 X 10mm)	
17.	116-489	AR	BULK EDGE (1/8",SOLD PER 1')	USE 1 @ 35.5"
18.	116-489	AR	BULK EDGE (1/8",SOLD PER 1')	USE 1 @ 31.5"
19.	116-489	AR	BULK EDGE (1/8",SOLD PER 1')	USE 2 @ 27.5"
20.	117-558	14	ADJUST LEVER LATCH (LOCKING)	
	214-961		KEY, PAIR (BASE CODE)	
	217-309		LOCK PLUG 4/LATCH (BASE CODE)	
	110-757	14	LEVER LATCH (ADJUST LOCKING)	INCL KEYS
	110-596		KEYS (PAIR)	
21.	106-991	79	FLG LOCK SCREW (M8-1.25 X 20mm)	
22.	106-551	75	CLIP NUT (M8-1.25)	
23.	354-884	1	PROP BAR	
24.	350-420	1	RIGHT DOOR	
25.	111-051	2	HINGE	
26.	111-052	2	HINGE	
27.	110-989	2	POCKET PULL	
28.	105-650	16	SCREW (M4-.70 X 10mm)	
29.	350-745	1	BACKUP BAR	

FOOTNOTES

ENGINE COVERS

REF NO.	PART NUMBER	QTY	DESCRIPTION	REMARKS
30.	184-870	2	SPACER	
31.	106-561	9	LOCKNUT (M8-1.25, PRV TRQ, 10.9)	
32.	115-686	AR	BULK EDGE (5/32", SOLD PER 1")	USE 1 @ 35.5"
33.	115-686	AR	BULK EDGE (5/32", SOLD PER 1")	USE 1 @ 8.0"
34.	115-477	1	GRIP RING (.375")	
35.	106-389	2	WASHER (M8)	
36.	308-718	1	DOOR	
37.	117-378	AR	BULK HOSE, L P (-12)(PER IN)	USE 1" @ 53.0", SEE FOOTNOTE 1
38.	115-033	2	GROMMET (1-1/4")	SEE FOOTNOTE 2
39.	106-386	4	FLG LOCKNUT (M8-1.25)	
40.	318-791	2	WEAR STRIP	
41.	106-992	7	FLG LK SCREW (M8-1.25 X 25MM)	
42.	318-481	-	SUPPORT	
43.	106-162	9	FLG SCREW(M8-1.25 X 20MM, GD8)	
44.	105-117	21	WASHER (5/16")	
45.	320-438	1	DOOR PANEL	

FOOTNOTES

1. INSTALL THROUGH HOLES IN TOP PANEL (309-236 REF#3) AFTER INSTALLING GROMMETS (115-033 REF#38).
2. INSTALL IN HOLES IN TOP PANEL (309-236 REF#3) BEFORE INSTALLING HOSE (117-378 REF#34).

SOUND INSULATION ENGINE COVERS

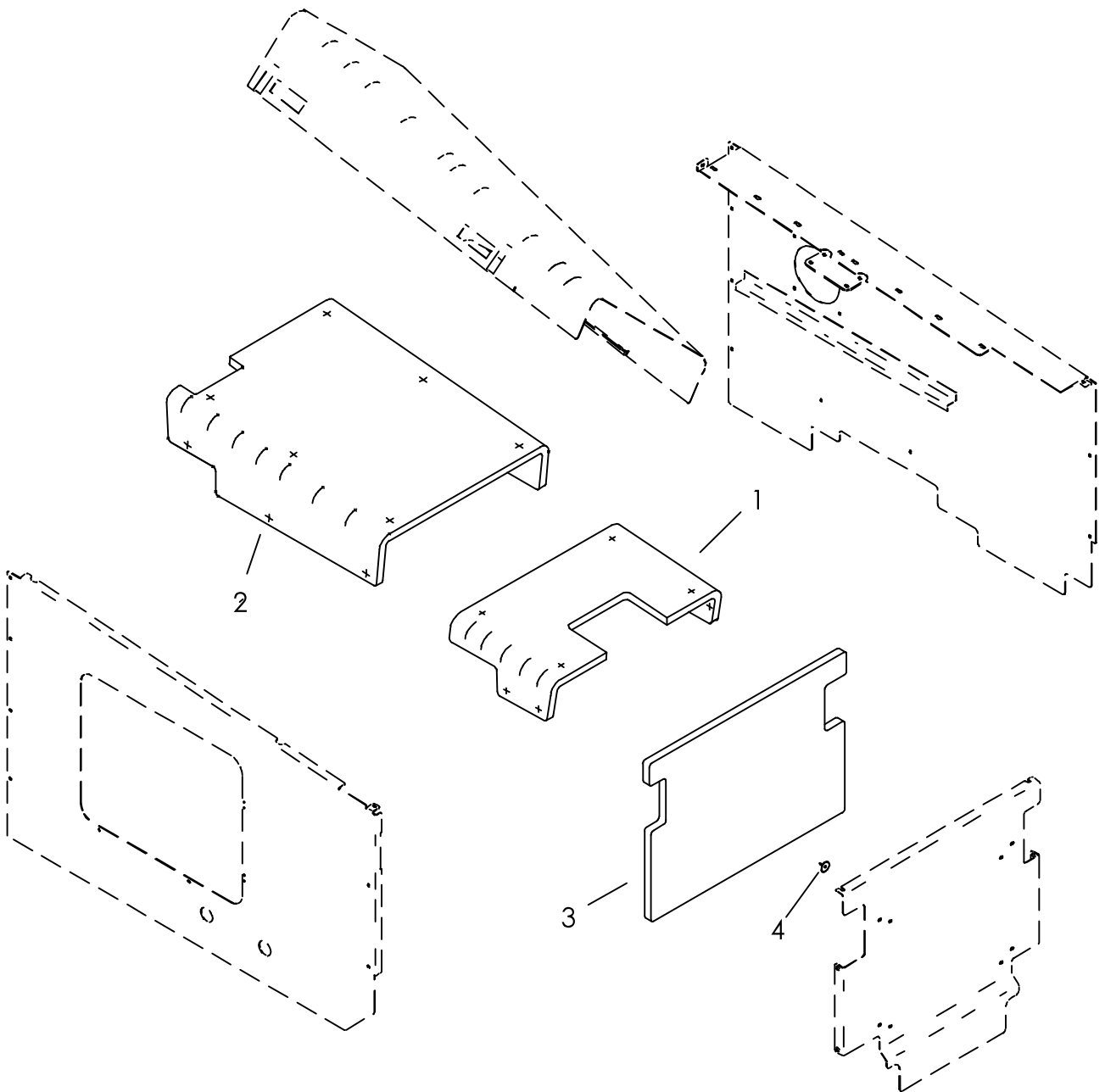

SOUND INSULATION ENGINE COVERS

REF NO.	PART NUMBER	QTY	DESCRIPTION	REMARKS
1.	354-937	1	SOUND INSULATION (HOOD-FRONT)	SEE FOOTNOTE 1, 2
2.	354-938	1	SOUND INSULATION (HOOD-REAR)	SEE FOOTNOTE 1, 2
3.	354-939	1	SOUND INSULATION (BATTERY PANEL)	
4.	107-950	20	INSULATION STUD	SEE FOOTNOTE 2

NOT SHOWN:

FOOTNOTES:

1. FIBERGLASS MUST BE SCORED ALONG BEND LINE TO ACHIEVE ACCEPTABLE BEND RESULTS
2. "X" MARKS ON INSULATION INDICATE APPROX LOCATION OF INSULATION STUDS

NOTE:

BATTERY COVERS

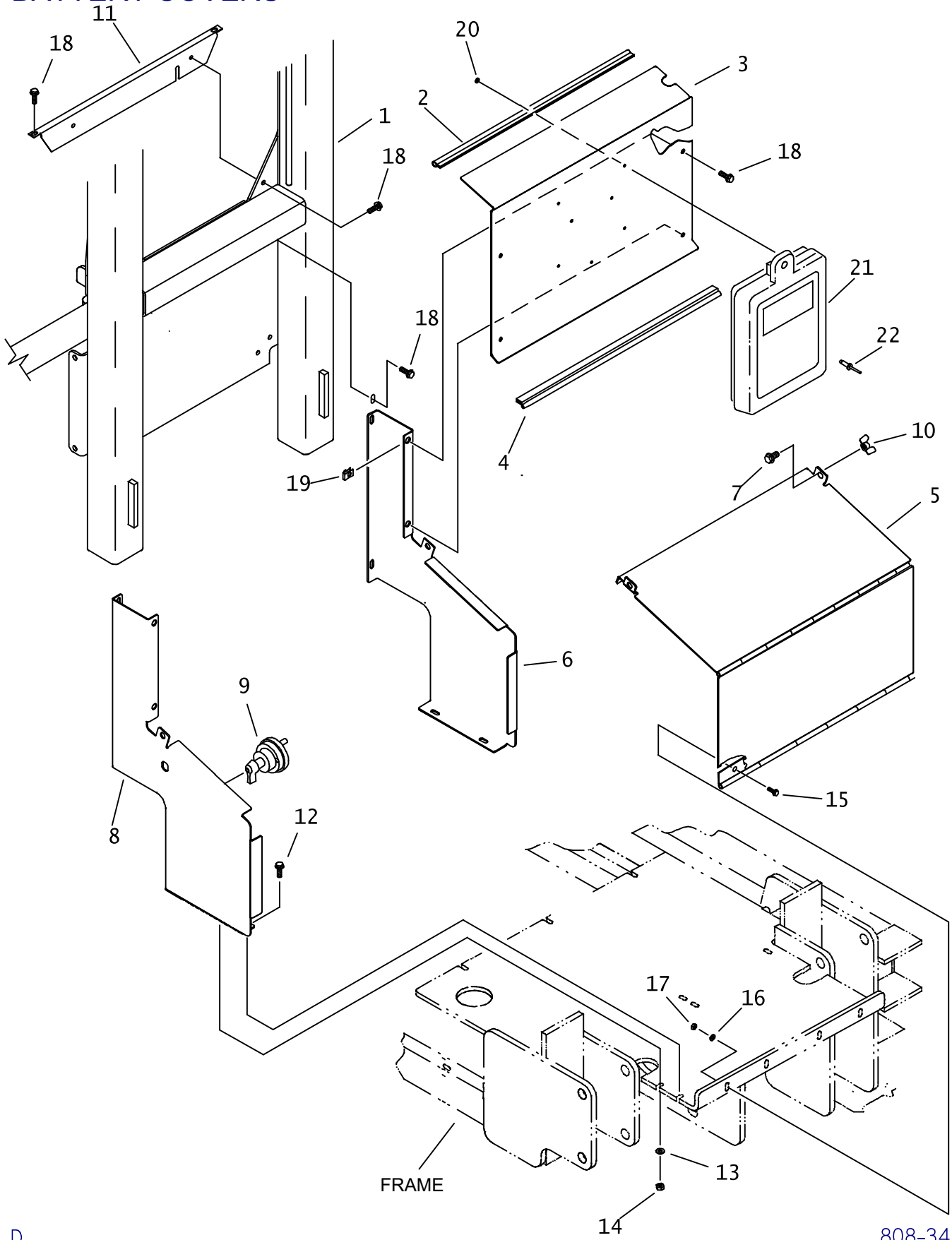

D

808-341

BATTERY COVERS

REF NO.	PART NUMBER	QTY	DESCRIPTION	REMARKS
1.	309-190	-	2-POST ROPS	
2.	116-421	AR	BULK EDGE (1/8", SOLD PER 1')	USE 1 @ 21.5"
3.	354-467	1	RELAY BOARD COVER	BEFORE S/N
	320-998	-	RELAY COVER	
4.	116-489	AR	BULK EDGE (1/8", SOLD PER 1')	USE 1 @ 22"
5.	354-880	1	BATTERY COVER	BEFORE S/N
	320-999	-	BATTERY COVER	
6.	354-469	1	BATTERY SIDE PANEL (LEFT)	BEFORE S/N
	322-370	-	BATTERY SIDE PANEL (LEFT)	
7.	105-825	2	FLG LK BOLT (3/8-NC X 3/4")	
8.	354-468	1	BATTERY SIDE PANEL (RIGHT)	BEFORE S/N
	322-371	-	BATTERY SIDE PANEL (RIGHT)	
9.	217-819	-	BATTERY DISCONNECT SWITCH	
10.	105-180	2	WING NUT (3/8-NC)	
11.	309-189	1	COVER PLATE	
12.	106-381	4	FLG LK SCREW (M8-1.25 X 25MM)	
13.	105-117	4	WASHER (5/16")	
14.	106-561	4	LOCKNUT (M8-1.25, PRV TRQ, 10.9)	
15.	106-988	4	FLG LK SCREW (M6-1.00 X 20MM)	
16.	105-117	4	WASHER (5/16")	
17.	106-538	4	LOCKNUT (M6-1.00, PRV TRQ, 10.9)	
18.	106-991	12	FLG LK SCREW (M8-1.25 X 20mm)	
19.	106-551	4	CLIP NUT (M8-1.25)	
20.	106-205	3	WASHER (.191")	
21.	318-588	1	MANUAL COMPARTMENT	
22.	110-560	4	POP RIVET (3/16" X 1/2", ALUM)	

FOOTNOTES

NOTE:

D

808-341

GAUGE PANEL

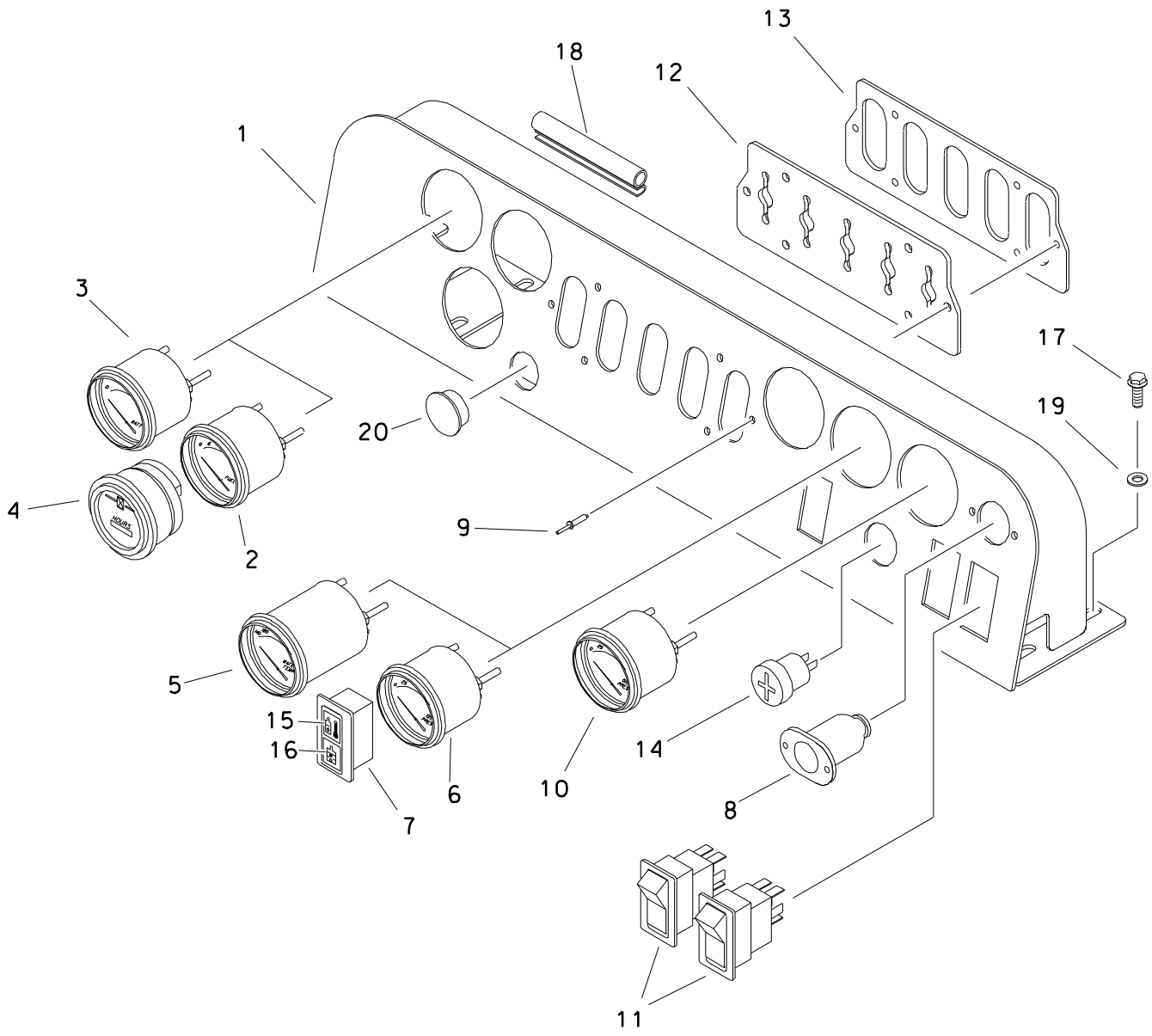

GAUGE PANEL

REF NO.	PART NUMBER	QTY	DESCRIPTION	REMARKS
1.	308-337	1	INSTRUMENT PANEL	
2.	215-133	-	FUEL GAUGE	
-	215-415	-	NITE-LIGHT KIT (12V DC)	
3.	215-129	-	VOLT METER	
-	215-415	-	NITE-LIGHT KIT (12V DC)	
4.	215-128	-	HOOR METER	
5.	258-037	-	WATER TEMPERATURE GAUGE	
-	215-415	-	NITE-LIGHT KIT (12V DC)	
6.	215-131	-	OIL PRESSURE GAUGE	
-	215-415	-	NITE-LIGHT KIT (12V DC)	
7.	217-020	-	PILOT LIGHT	ON-ON, SPDT
-	217-046	-	BULB (12V DC)	
8.	214-301	-	ACCESSORY SOCKET	
9.	110-560	8	PDP RIVET (3/16" X 1/2", ALUM)	
10.	211-070	-	TACHOMETER (3000 RPM)	
11.	217-907	-	ROCKER SWITCH (DPDT) ON-ON	
12.	117-383	1	CONTROL HANDLE SEAL	
13.	310-126	1	SEAL BACK-UP PANEL	
14.	306-603	-	AUDIO ALARM	
15.	217-027	-	INSERT (RED) HYD OIL HI TEMP	
16.	217-036	-	INSERT (YELLOW) HYD OIL PSI	
17.	106-987	4	FLG LOCK SCREW (M6-1.00 X 16mm)	
18.	116-489	AR	BULK EDGE (1/8", SOLD PER 1 FT)	USE 1 @ 32.5"
19.	106-076	4	WASHER (1/4")	
20.	111-112	1	PLUG (1.00)	

NOT SHOWN:

106-574	5	CLIP NUT (M6-1.00)	ATTACH TO HYDRAULIC TANK
---------	---	--------------------	--------------------------

FOOTNOTES

NOTES:

OPERATOR'S STATION

OPERATOR STATION

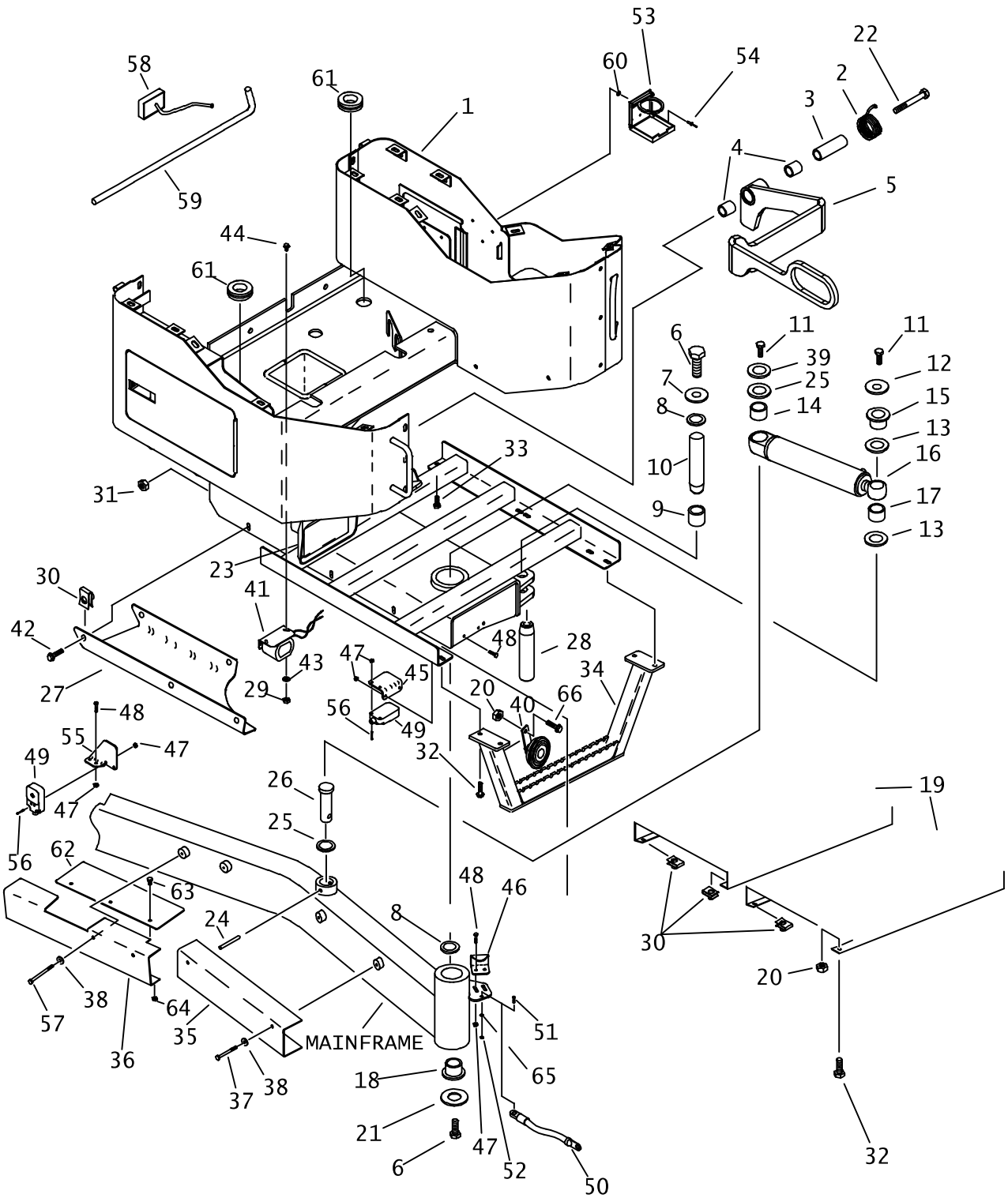

OPERATOR STATION

REF NO.	PART NUMBER	QTY	DESCRIPTION	REMARKS
1.	313-733	1	OPERATOR FRAME	
2.	117-156	1	TORSION SPRING	
3.	354-454	1	HANDLE SPACER	
4.	125-813	2	COMPOSITION BUSHING (1")	
5.	319-499	1	HANDLE	
6.	106-345	2	SCREW (M20-2.50 X 50mm)	
7.	105-423	1	WASHER (3/4")	
8.	111-001	2	WASHER (M51.2)	
9.	125-754	1	COMPOSITION BUSHING (2")	
10.	179-226	1	TAPERED PIN (50.8mm X 272mm)	
11.	105-245	2	SCREW (M10-1.50 X 25mm)	
12.	106-396	1	WASHER (M10, HARDENED)	
13.	110-084	2	BRASS BUSHING (1-5/32")	
14.	125-771	1	COMPOSITION BUSHING (1.25")	
15.	181-981	1	TAPERED INSERT (1")	
16.	151-031	1	CYL (2" X 1" X 8")	
17.	125-770	1	COMPOSITION BUSHING (1")	
18.	184-064	1	TAPERED INSERT (2")	
19.	350-989	2	FLOOR TREADS	
20.	106-561	5	LOCKNUT (M8-1.25, PRV TRQ, 10.9)	
21.	106-399	1	WASHER (M20, HARDENED)	
22.	106-336	1	SCREW (M12-1.75 X 90mm)	
23.	217-007	1	WORKING LIGHT (CLEAR, RECT)	
24.	105-503	1	ROLL PIN (1/4" X 2")	
25.	110-093	2	MACHINERY BUSHING (1-1/4", 18GA)	
26.	179-225	1	PIN (31.75mm X 60mm)	
27.	350-988	1	CHANNEL COVER	
28.	183-767	1	TAPERED PIN (25.4mm X 60mm)	
29.	106-538	2	LOCKNUT (M6-1.00, PRV TRQ, 10.9)	
30.	106-551	11	CLIP NUT (M8-1.25)	
31.	106-685	1	LOCKNUT (M12-1.75, PRV TRQ, 10.9)	
32.	106-381	5	FLG LK SCREW (M8-1.25 X 25MM)	
33.	106-992	6	FLG LK SCREW (M8-1.25 X 25MM)	
34.	354-488	1	STEP	
35.	354-500	1	WIRE COVER	
36.	314-723	1	COVER	
37.	106-595	2	SCREW (M6-1.00 X 60mm)	
38.	106-388	4	WASHER (M6)	
39.	105-223	1	WASHER (3/8")	
40.	192-006	1	HIGH FREQUENCY HORN	
	192-005	1	HORN BRACKET	
	306-609	1	HIGH FREQUENCY HORN-----	OBSOLETE
41.	214-416	1	HORN (ELECTRIC)	
42.	106-991	5	FLG LK SCREW (M8-1.25 X 20MM)	

NOT SHOWN:

FOOTNOTES:

NOTE:

OPERATOR STATION

REF NO.	PART NUMBER	QTY	DESCRIPTION	REMARKS
43.	106-389	2	WASHER (M8)	
44.	106-161	2	FLG SCREW (M6-1.00 X 20MM)	
45.	307-773	1	BRACKET, SWITCH	
46.	307-771	1	TARGET PLATE	
47.	106-850	10	LOCKNUT (M5-.80)	
48.	107-430	6	SCREW (M5 X 14MM)	
49.	215-1175	2	PROXIMITY SWITCH	
50.	214-088	1	CABLE ASS'Y (6GA X 200 MM)	
51.	106-217	1	BOLT (1/4-NC X 1", SIL BRZ)	
52.	106-455	1	LOCKNUT (1/4-NC, SIL BRZ)	
53.	354-905	1	CUP HOLDER	
54.	110-560	3	POP RIVET (3/16" X 1/2", ALUM)	
55.	307-772	1	BRACKET, SWITCH	
56.	106-427	4	SCREW (M5-0.80 X 22MM, SOC)	
57.	106-945	2	SCREW (M6-1.00 X 100MM)	
58.	211-042	1	CURRENT TRANSFORMER	
59.	215-799	1	VOLTAGE STAKE	
60.	106-205	3	WASHER (.191")	
61.	115-355	2	GROMMET (1-3/8)	
62.	315-649	1	PLATE	
63.	106-234	3	SCREW (M6-1.00 X 12MM)	
64.	106-106	3	NUT (M6-1.00)	
65.	106-221	1	INT STAR WASHER (1/4", SIL BRZ)	
66.	106-162	1	FLG SCREW (M8-1.25 X 20MM)	

NOT SHOWN:

107-269	4	SCREW (#4-40 X 3/4", PAN)
106-277	4	NUT (#4-40, BRASS)
117-283	1	ABRASION SLEEVE (4.000" X 20")

FOOTNOTES:

NOTE:

SEAT-BELT-COVER

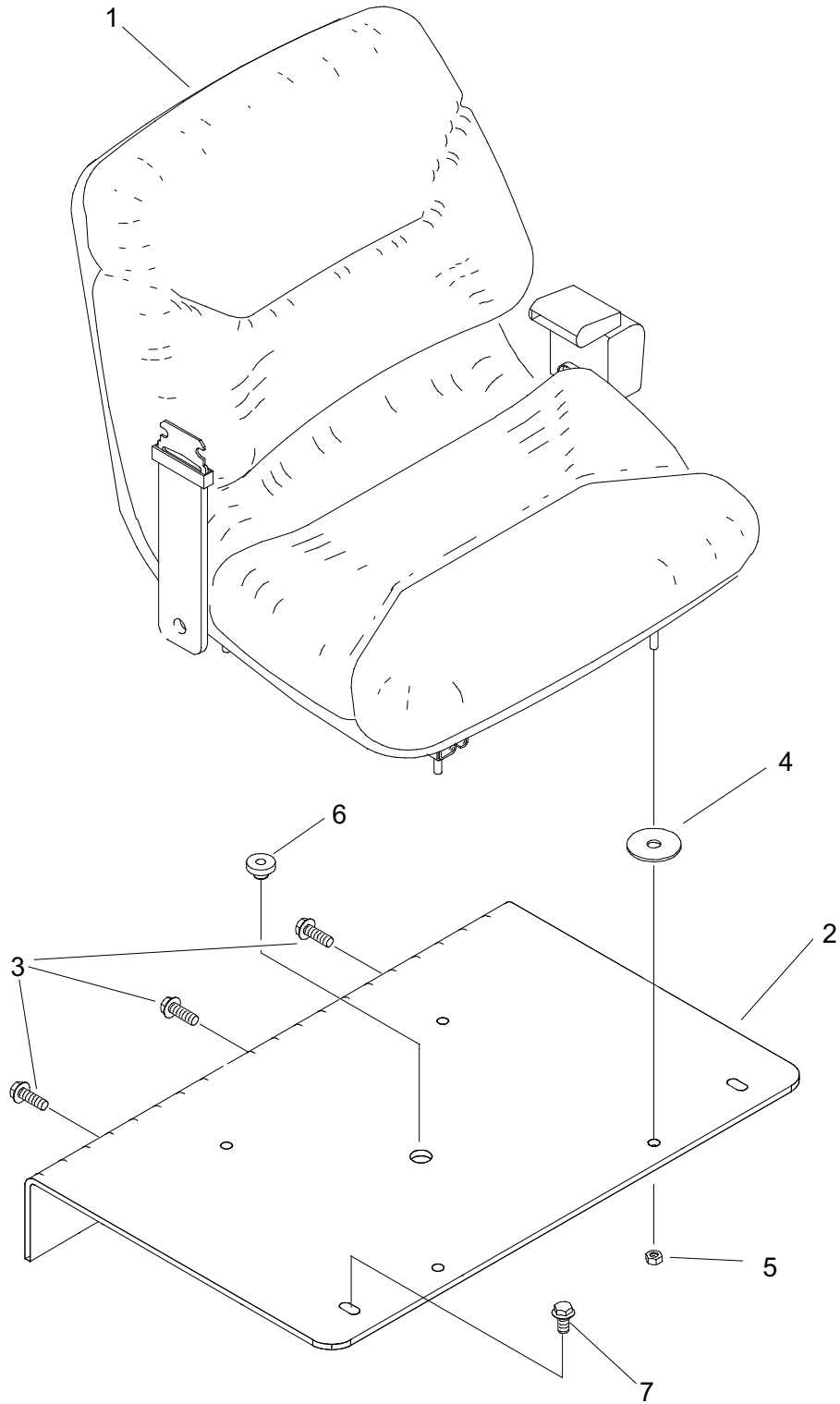

SEAT-BELT-COVER

REF NO.	PART NUMBER	QTY	DESCRIPTION	REMARKS
1.	117-1000	1	SEAT ASS'Y W/ SEAT BELT	INCL SWITCH
	214-964	-	SEAT SWITCH W/ BOOT	
	214-965	-	SEAT SWITCH HARNESS	
2.	308-787	1	SEAT BASE	
3.	107-001	3	FLG LK SCREW (M10-1.50 X 25mm)	
4.	105-267	4	CUP WASHER (5/16")	
5.	106-561	4	LOCKNUT (M8-1.25,PRV TRQ,10.9)	
6.	116-203	1	GROMMET (9/16")	
7.	106-999	2	FLG LK SCREW (M10-1.50 X 20mm)	

NOT SHOWN:

FOOTNOTES:

NOTE:

CONSOLE

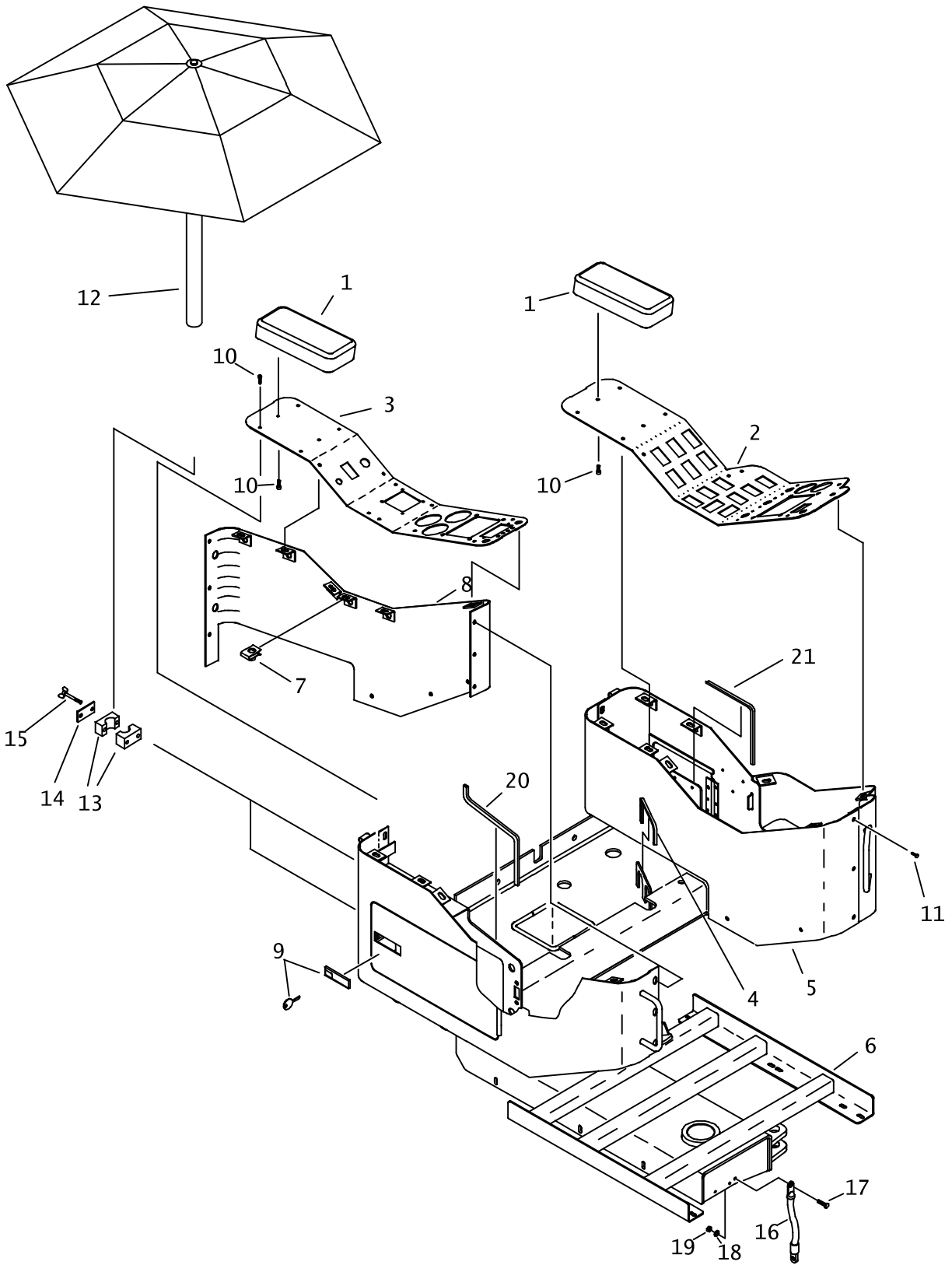

CONSOLE

REF NO.	PART NUMBER	QTY	DESCRIPTION	REMARKS
1.	350-389	2	ARM REST PAD	
2.	313-729	1	LEFT CONSOLE COVER	
3.	211-011	1	RIGHT CONSOLE	
4.	116-789	AR	RUBBER EDGE TRIM 1/8" (12 GA)	USE 2 @ 10"
5.	350-749	1	LEFT CONSOLE	
6.	313-733	-	OPERATOR FRAME	
7.	106-574	37	CLIP NUT (M6-1.00)	
8.	308-790	1	RIGHT CONSOLE	
9.	117-558	2	ADJUST LEVER LATCH (LOCKING)	
	214-961		KEY, PAIR (BASE CODE)	
	217-309		LOCK PLUG 4/LATCH (BASE CODE)	
	<u>110-757</u>	2	LEVER LATCH (ADJUST LOCKING)	INCLUDES KEYS
	110-596	-	KEY (PAIR)	
10.	106-640	24	SCREW (M6-1.00 X 20mm, BUT SOC)	
11.	106-988	17	FLG LK SCREW (M6-1.00 X 20mm)	
12.	344-0001	1	UMBRELLA (6.5')	
	500-1962	-	POLE (16")	
13.	111-026	2	BOLT-ON CLAMP (1-1/4", PAIR)	
14.	322-362	2	BACKUP SPACER	
15.	105-621	4	WING BOLT (1/4-NC X 3")	
16.	214-088	-	CABLE ASS'Y (6GA X 200 MM)	
17.	106-217	1	BOLT (1/4-NC X 1", SIL BRZ)	
18.	106-221	1	INT STAR WASHER (1/4", SIL BRZ)	
19.	106-455	1	LOCKNUT (1/4-NC, SIL BRZ)	
20.	116-789	AR	RUBBER EDGE TRIM 1/8" (12 GA)	USE 1 @ 19"
21.	116-789	AR	RUBBER EDGE TRIM 1/8" (12 GA)	USE 1 @ 22"

NOT SHOWN:

FOOTNOTES:

NOTE:

CONSOLE GAUGES

JT42T2 / AT42T2
JT42T3 / AT42T3

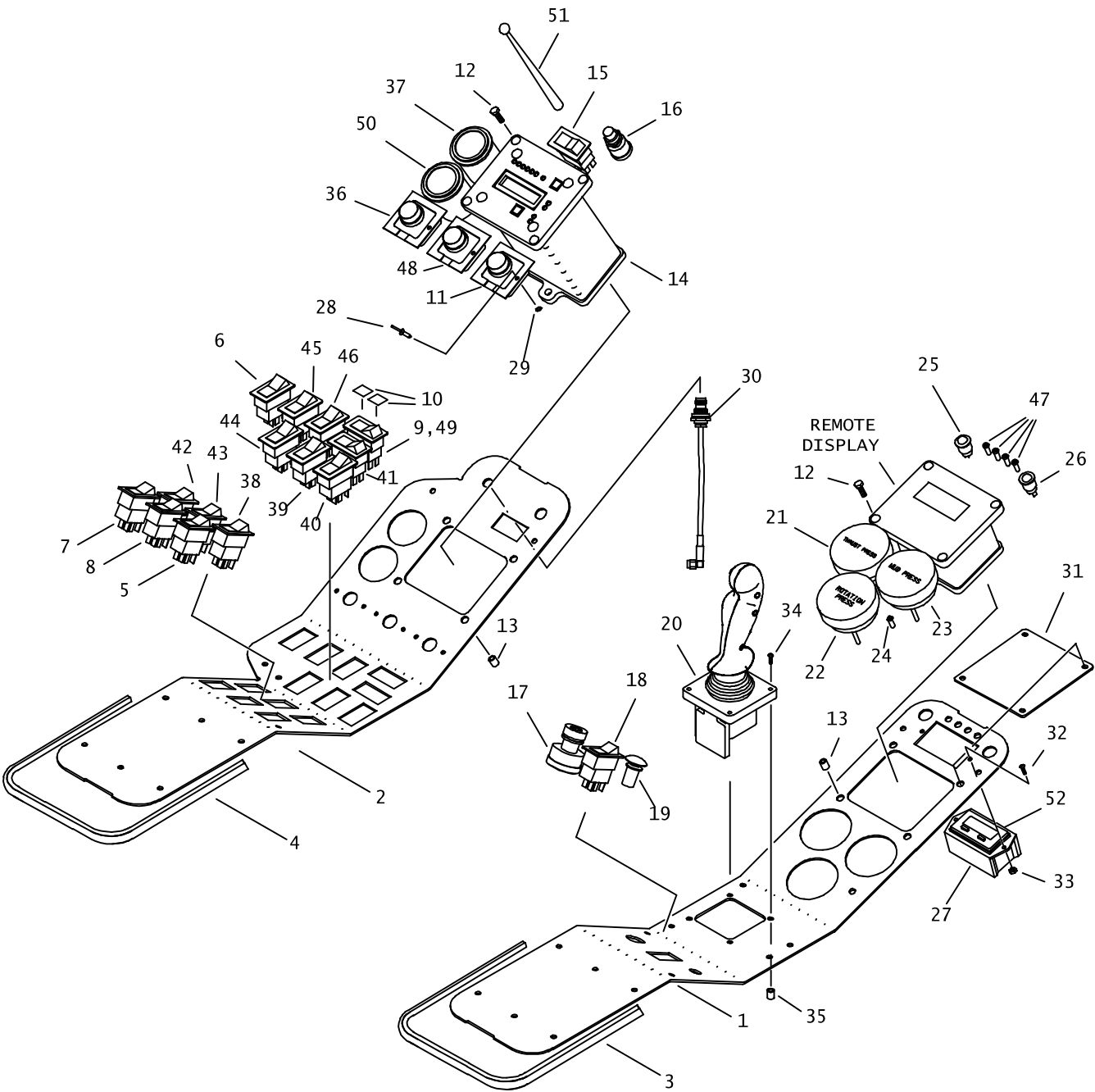

CONSOLE GAUGES

JT42T2 / AT42T2

JT42T3 / AT42T3

REF NO.	PART NUMBER	QTY	DESCRIPTION	REMARKS
1.	211-011	-	RIGHT CONSOLE COVER	
2.	313-729	-	EFT CONSOLE COVER	
3.	116-789	AR	RUBBER EDGE TRIM 1/8 " (12 GA)	USE 1 @ 86"
4.	116-789	AR	RUBBER EDGE TRIM 1/8 " (12 GA)	USE 1 @ 83"
5.	214-489	-	ROCKER SW (DPDT) (ON)-OFF-(ON)	THROTTLE
6.	217-908	1	ROCKER SWITCH (DPDT) ON-ON-ON	INNER SPINDLE ON-OFF-(MAN), AT ONLY
	110-962	-	FILLER PLUG	JT ONLY
7.	217-912	-	ROCKER SWITCH (DPDT) ON-ON-ON	BORE/BACKREAM
8.	217-907	-	ROCKER SWITCH (DPDT) ON-ON	OUTER SPINDLE BRAKE
9.	217-923	-	ROCKER SW (DPDT) ON-OFF-ON	MOBILE/BORE
10.	217-156	2	DIFFUSION LENS (GREEN)	
11.	214-566	-	POTENTIOMETER	DRILL FLUID POT.
12.	106-640	8	SCREW (M6-1.00 X 20MM,BUT SOC)	
13.	105-630	8	NUTSERT(M6X1.0).70-4.20THK	
14.	217-241	-	ESID MODULE	ELECTRICAL STRIKE SYSTEM
15.	217-911	-	ROCKER SWITCH (SPDT) ON-OFF-ON	SEAT ROTATE
16.	306-607	-	HORN BUTTON	HORN
	306-608	-	BUTTON COVER	
17.	214-852	1	IGNITION SWITCH	
	214-961	-	KEY, PAIR	
	214-962	-	SWITCH MOUNTING NUT	
18.	217-917	-	ROCKER SWITCH (DPDT) OFF-(ON)	COLD START
19.	217-206	-	BUTTON SWITCH (SPST)	ENGINE STOP
20.	215-1224	-	DUAL AXIS JOYSTICK	JOYSTICK
21.	258-063	-	GAUGE (4000 PSI)	THRUST PRESSURE GAUGE
22.	258-061	-	HYD PRESSURE GAUGE (6000 PSI)	INNER/OUTER ROTATION PRESSURE GAUGE
23.	258-062	-	PRESSURE GAUGE (1500PSI)	MUD PRESSURE GAUGE
24.	214-701	-	STATUS LIGHT	"MUD ON" LED
25.	214-563	-	RED LED 12V	DIAGNOSTIC LIGHT
26.	214-840	-	GREEN LED (12V DC)	CONTROL CYCLE LIGHT
27.	217-221	-	FLOW METER DISPLAY	MUD FLOW METER
28.	110-560	6	POP RIVET (3/16" X 1/2 ", ALUM)	
29.	106-205	6	WASHER (.191")	
30.	214-413	-	RIG RF CABLE 2130MM	
31.	348-896	1	COVER PLATE	COVER FOR HOLE WHEN REMOTE DISPLAY IS NOT INSTALLED.
32.	106-049	2	BOLT (#10-24 X 3/4 ", PLPS)	
33.	106-048	2	LOCKNUT (#10-24)	
34.	107-414	4	SCREW (M4-0.70 X 30MM, BUT SOC)	
35.	107-635	4	NUTSERT (M4 X 0.7)	
36.	211-089	-	4.5V-12.0V POTENTIOMETER	INNER SPINDLE POT., AT ONLY
37.	217-561	-	SPINDLE TACHOMETER (250 RPM)	OUTER SPINDLE TACH, AT ONLY
	111-067	-	EXPANSION PLUG (2.125")	JT ONLY
38.	214-489	-	ROCKER SW (DPDT) (ON)-OFF-(ON)	PIPE SHUTTLE
39.	217-907	-	ROCKER SWITCH (DPDT) ON-ON	REAR WRENCH

NOT SHOWN:

FOOTNOTES:

NOTE:

CONSOLE GAUGES

JT42T2 / AT42T2

JT42T3 / AT42T3

REF NO.	PART NUMBER	QTY	DESCRIPTION	REMARKS
40.	217-907	-	ROCKER SWITCH (DPDT) ON-ON	FRONT WRENCH
41.	214-489	-	ROCKER SW (DPDT) (ON)-OFF-(ON)	LUBER
42.	214-489	-	ROCKER SW (DPDT) (ON)-OFF-(ON)	PIPE LIFT
43.	214-489	-	ROCKER SW (DPDT) (ON)-OFF-(ON)	PIPE GRIP
44.	214-489	-	ROCKER SW (DPDT) (ON)-OFF-(ON)	WRENCH ROTATE
45.	214-489	-	ROCKER SW (DPDT) (ON)-OFF-(ON)	INNER SPINDLE MANUAL CW/CCW, AT ONLY
	110-962	-	FILLER PLUG	JT ONLY
46.	214-489	-	ROCKER SW (DPDT) (ON)-OFF-(ON)	CRUISE CONTROL
47.	214-701	-	STATUS LIGHT	
48.	214-566	-	POTENTIOMETER	OUTER SPINDLE POT.
49.	217-925	-	ROCKER SWITCH (ACTUATOR)	
50.	211-099	-	SPINDLE TACHOMETER (250 RPM)	INNER SPINDLE TACH, AT ONLY
	111-067	-	EXPANSION PLUG (2.125")	JT ONLY
51.	221-177	-	ANTENNA UHF US-UK EXR450TN CEN	USA
	219-948	-	ANTENNA 420-450MHZ RT ANG TNC	INTERNATIONAL
52.	319-412	1	FLOW METER WEATHER COVER	

NOT SHOWN:

FOOTNOTES:

NOTE:

DUAL AXIS JOYSTICK

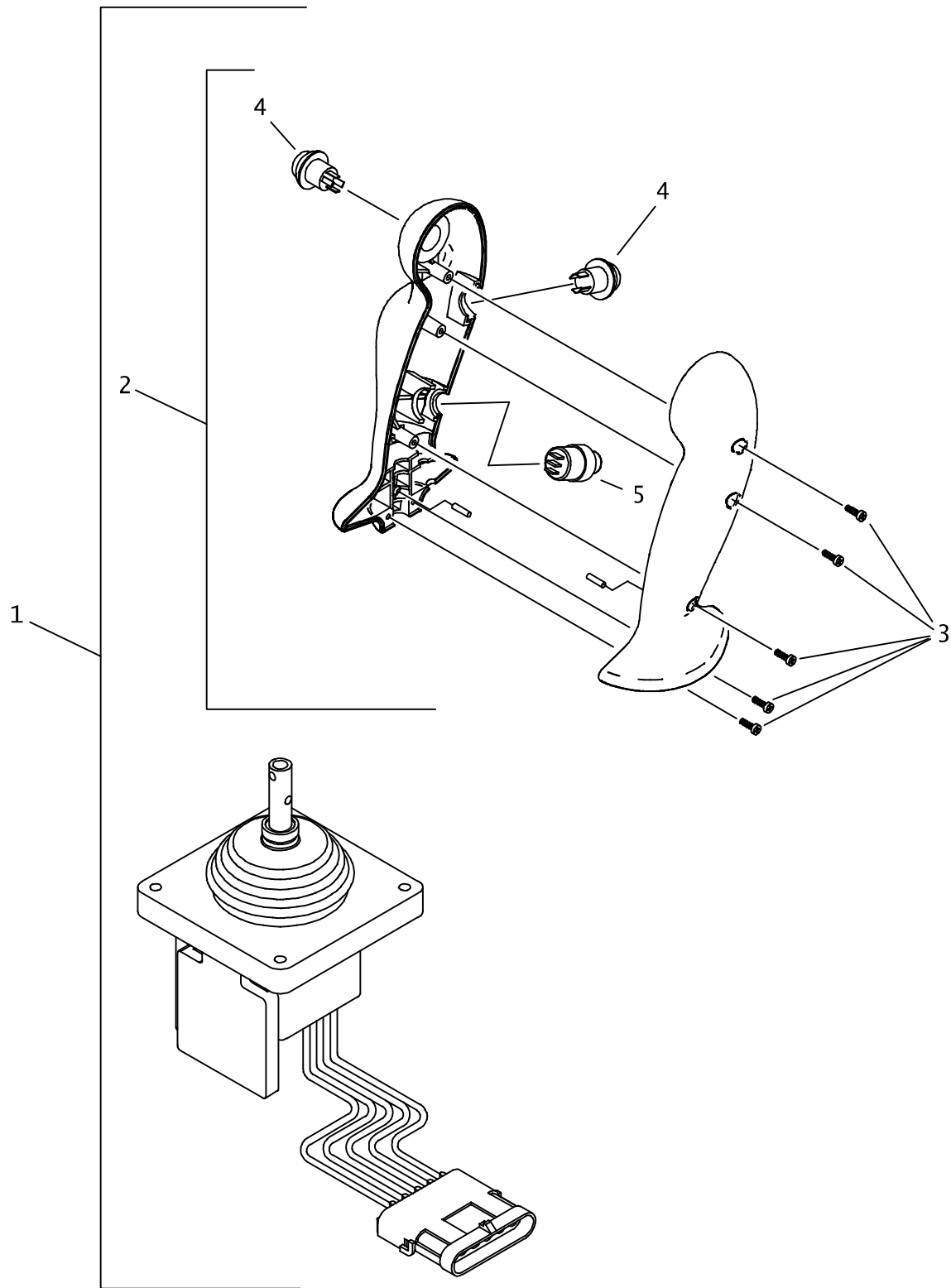

DUAL AXIS JOYSTICK

REF NO.	PART NUMBER	QTY	DESCRIPTION	REMARKS
1.	215-1224	-	DUAL AXIS JOYSTICK	
2.	500-1433	-	JOYSTICK HANDLE ASSEMBLY	INCLUDES REF No's 3,4,& 5
3.	107-410	-	SCREW (#2.5 X 8", PAN, PLASTIC)	
4.	214-614	-	PUSHBUTTON SW (SPST) OFF-(ON)	
5.	214-616	-	PUSHBUTTON SW (SPDT) ON-ON	

NOT SHOWN:

FOOTNOTES:

NOTE:

NOTES:

TRACK FRAME & MAIN FRAME

TRACK GROUP

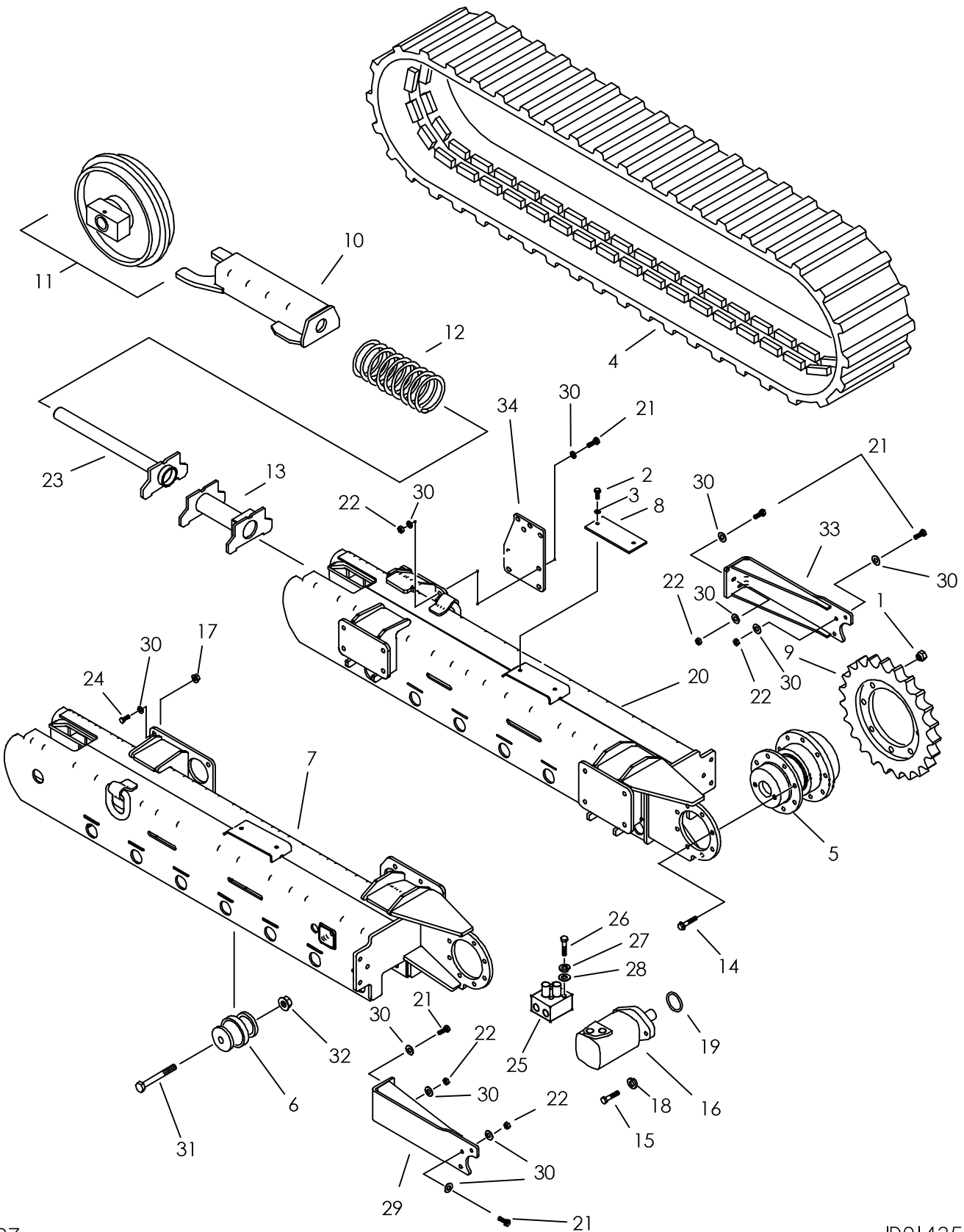

TRACK GROUP

REF NO.	PART NUMBER	QTY	DESCRIPTION	REMARKS
1.	106-066	16	LUG NUT (5/8-NF)	
2.	107-010	4	FLG LOCK SCREW (M12-1.75 X 30mm)	
3.	106-397	4	WASHER (M12, HARDENED)	
4.	354-480	2	RUBBER TRACK (400MM,82P,72MM)	
5.	166-417	2	PLANETARY GEARBOX	TRACK PLANETARY, USE 500-2009 O-RING/GASKET KIT
	500-1755	-	INPUT SHAFT	
6.	354-861	14	ROLLER	
7.	350-757	1	LEFT ROLLER FRAME	
8.	349-314	2	SLIDE PAD	
9.	141-578	2	SPROCKET (20T)	
10.	354-517	2	YOKE	
11.	354-860	2	IDLER PARTS ASS'Y	
12.	117-164	2	COMPRESSION SPRING	COMPRESSED LENGTH 18" +0 -1/4" TO KEEP TRACKS TIGHT
13.	354-531	1	RIGHT GREASE CYLINDER	
	354-530	1	LEFT GREASE CYLINDER	
14.	105-970	16	FLG BOLT (5/8-NC X 2-1/2")	USE 242 LOCTITE
15.	107-773	4	SCREW (1/2-NC X 4.25", GD8)	USE 242 LOCTITE; TORQUE TO 130 FT LB
16.	153-592	1	HYDRAULIC MOTOR	RIGHT SIDE, USE SEAL KIT 500-752
	153-593	1	HYDRAULIC MOTOR	LEFT SIDE
17.	106-442	16	FLG LKNUT (M16-2.00, PRV TRQ, 10.9)	TORQUE SPECS.: SEE FOOTNOTE 1
18.	105-070	4	LOCK WASHER (.500")	
19.	155-768	2	O-RING (155 D70)	
20.	350-758	1	RIGHT ROLLER FRAME	
21.	106-616	20	SCREW (M16-2.00 X 55mm, 10.9)	
22.	106-545	27	LOCKNUT (M16-2.00,PRV TRQ, 10.9)	
23.	354-529	2	SPRING GUIDE	
24.	107-598	16	SCREW (M16 X 60MM 10.9)	
25.	153-767	2	COUNTERBALANCE MANIFOLD	
	158-020	2	HYDRAULIC VALVE	
26.	107-739	8	SCREW (3/8-NF X 5.25", GD 5)	
27.	105-072	8	LOCK WASHER (3/8")	
28.	106-390	8	WASHER (M10)	
29.	354-569	1	LEFT TRACK GUARD	
30.	106-398	56	WASHER (M16, HARDENED)	
31.	105-597	14	BOLT (1-NC X 7.50", GD8)	USE 242 LOCTITE
32.	105-919	14	FLG NUT (1-NC)	
33.	354-570	1	RIGHT TRACK GUARD	
34.	350-831	1	ROPS SUPPORT PLATE	

NOT SHOWN:

FOOTNOTES:

1. APPLY LOCTITE 242;TIGHTEN ALL TRACK-MAIN FRAME JOINT FASTENERS TO 150 FT LB AND FINAL TORQUE OF 225 FT LB AT NUT; OR INITIAL TORQUE TO 125 FT LB AND FINAL TORQUE TO 185 FT LB AT BOLT HEAD. DO NOT DRAW MATING SURFACES TOGETHER WITH A SINGLE NUT-BOLT COMBINATION.

NOTE:

IDLER

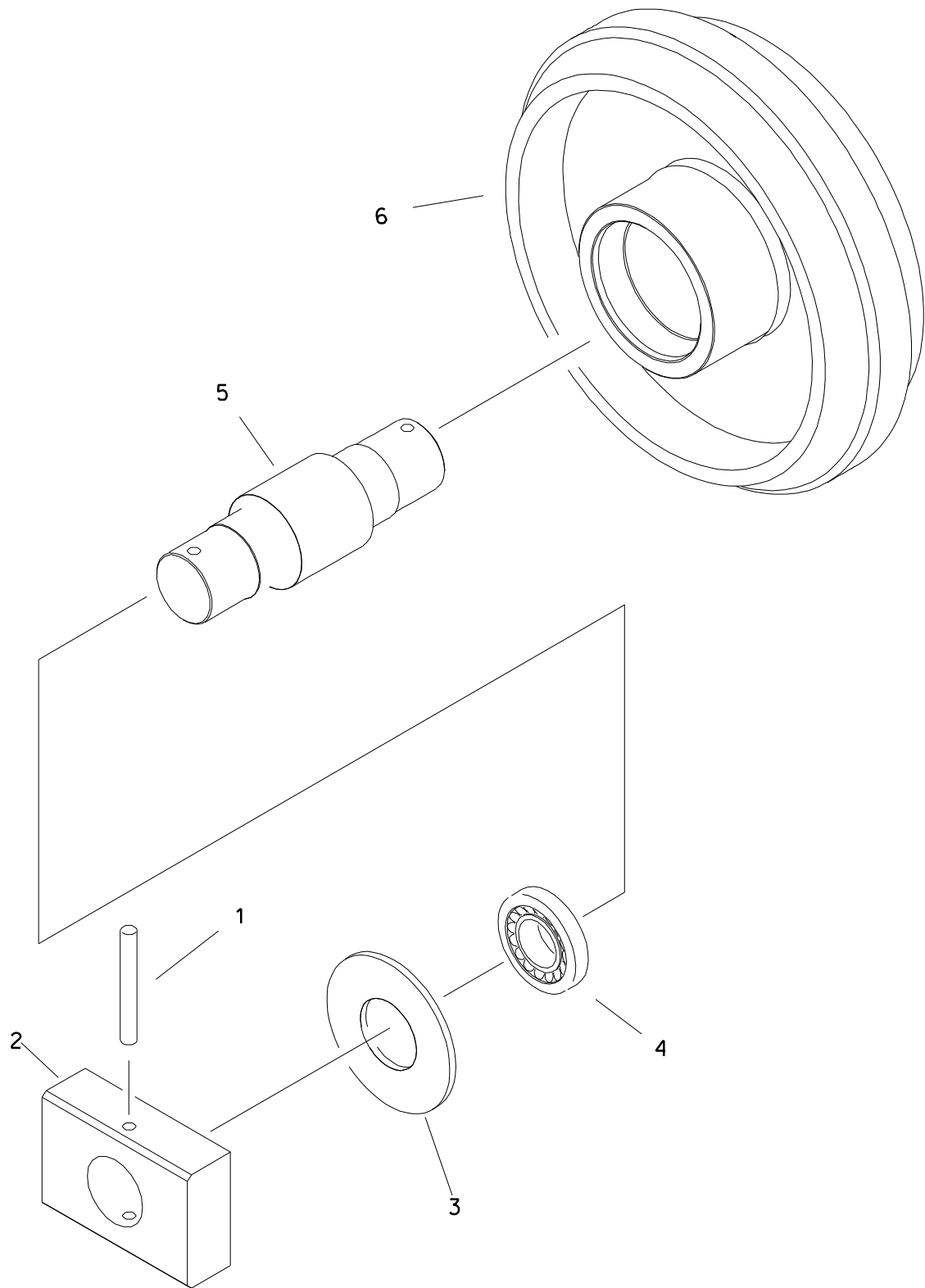

IDLER

REF NO.	PART NUMBER	QTY	DESCRIPTION	REMARKS
	354-860		IDLER	INCL REF NO'S 1 - 6
1.	107-295	2	ROLL PIN (.375" X 3.75")	
2.	354-833	2	OUTER BLOCK	
3.	125-482	2	WASHER (2.283")	
4.	125-134	2	BALL BEARING (2.362")	PACK WITH GREASE
5.	354-827	1	IDLER SHAFT	
6.	350-515	1	IDLER	PACK INSIDE WITH GREASE

FOOTNOTES

ROLLER

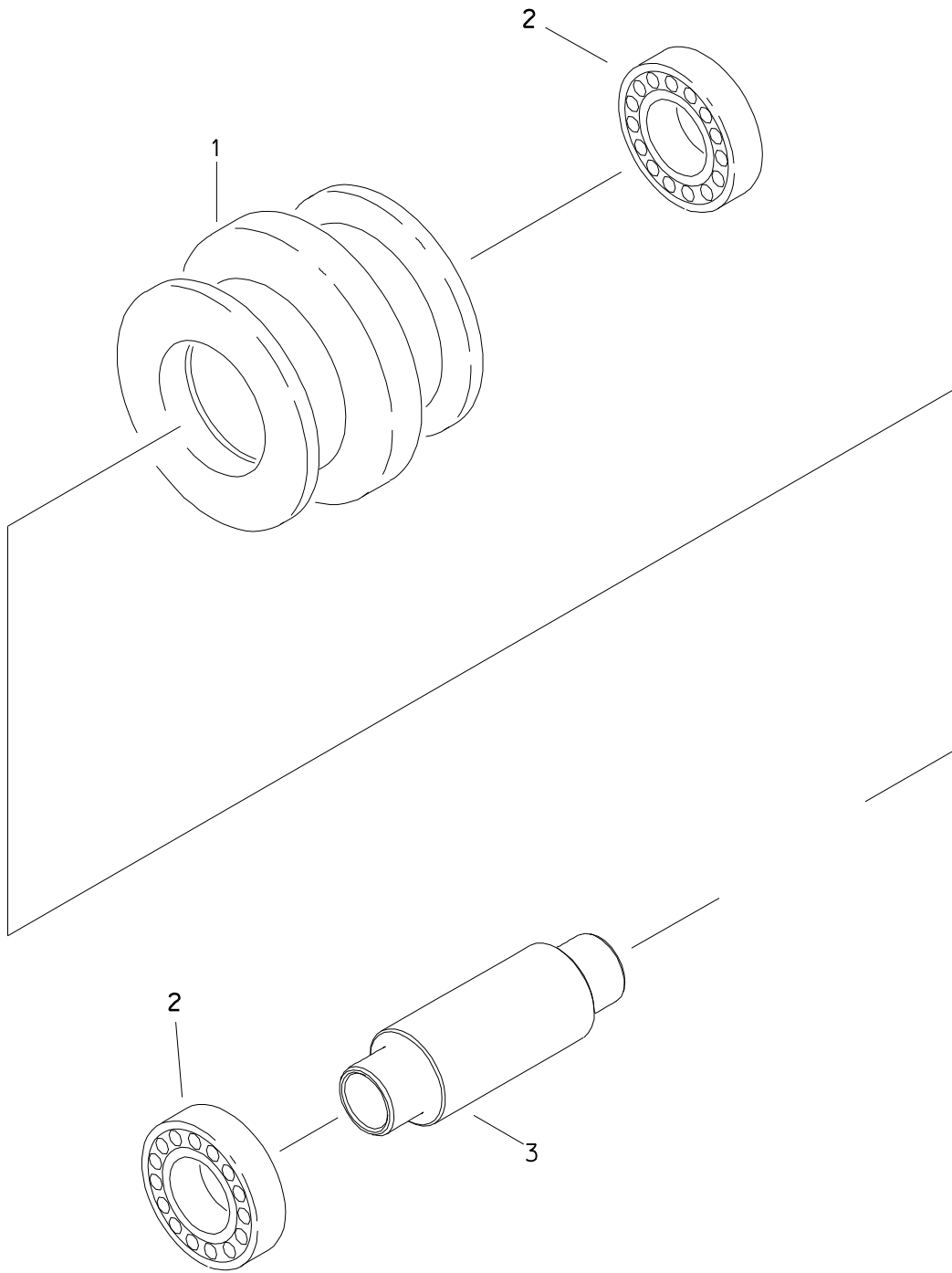

GREASE CYLINDER

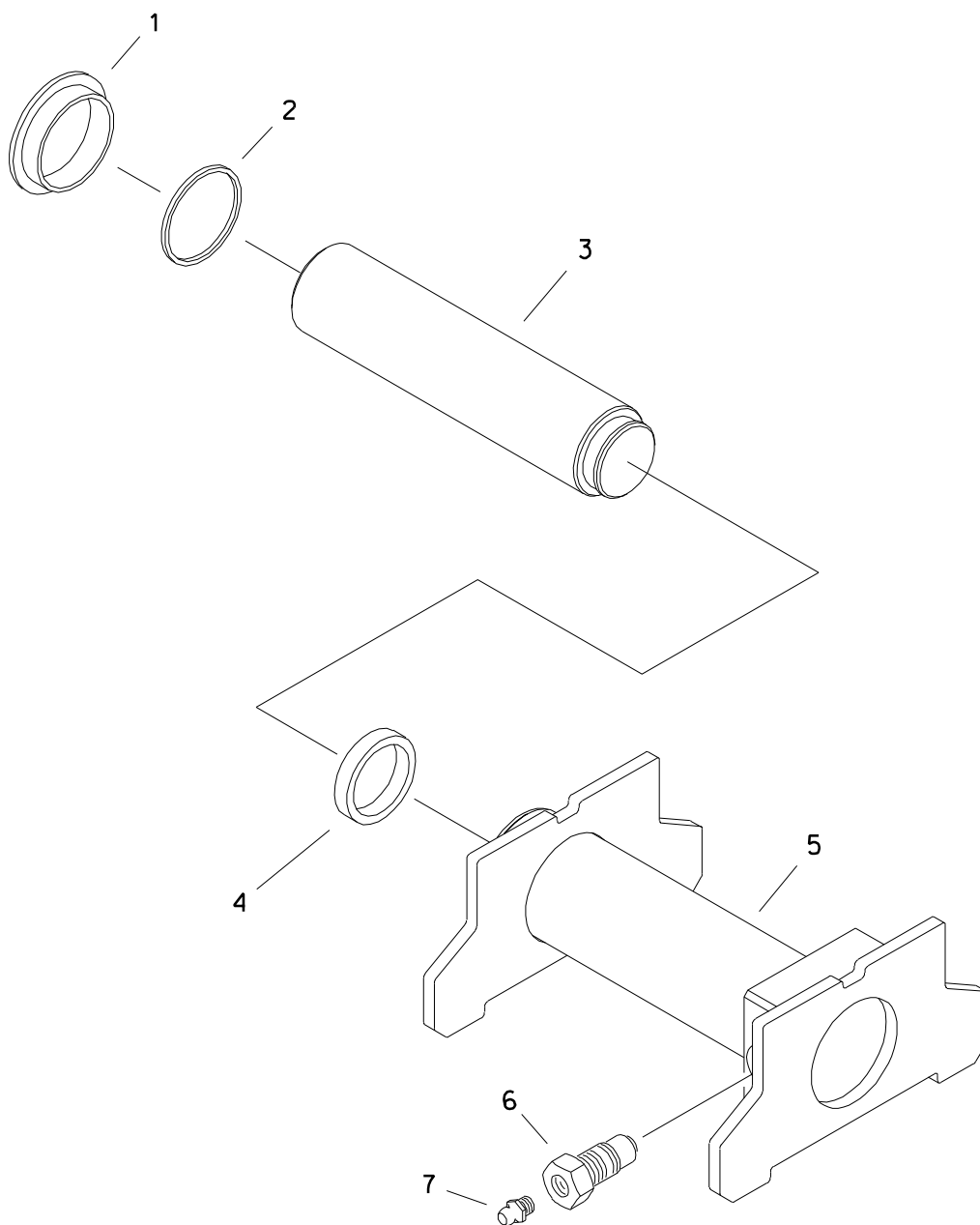

GREASE CYLINDER

REF NO.	PART NUMBER	QTY	DESCRIPTION	REMARKS
	354-530	1	LEFT GREASE CYLINDER	INCL REF NO'S 1 THRU 7
	354-531	1	RIGHT GREASE CYLINDER	INCL REF NO'S 1 THRU 7
1.	157-562	1	RETAINER RING (2.625")	
2.	157-561	1	ROD WIPER (2.492")	
3.	150-682	1	GREASE CYLINDER ROD	
4.	157-560	1	PISTON SEAL (1.975")	
5.	151-184	1	RIGHT BARREL	
	151-183	1	LEFT BARREL	
6.	159-093	1	RELIEF VALVE (5/8-NF, Q2N)	
7.	115-019	1	ZERK (Q2N)	

FOOTNOTES

REAR STABILIZER

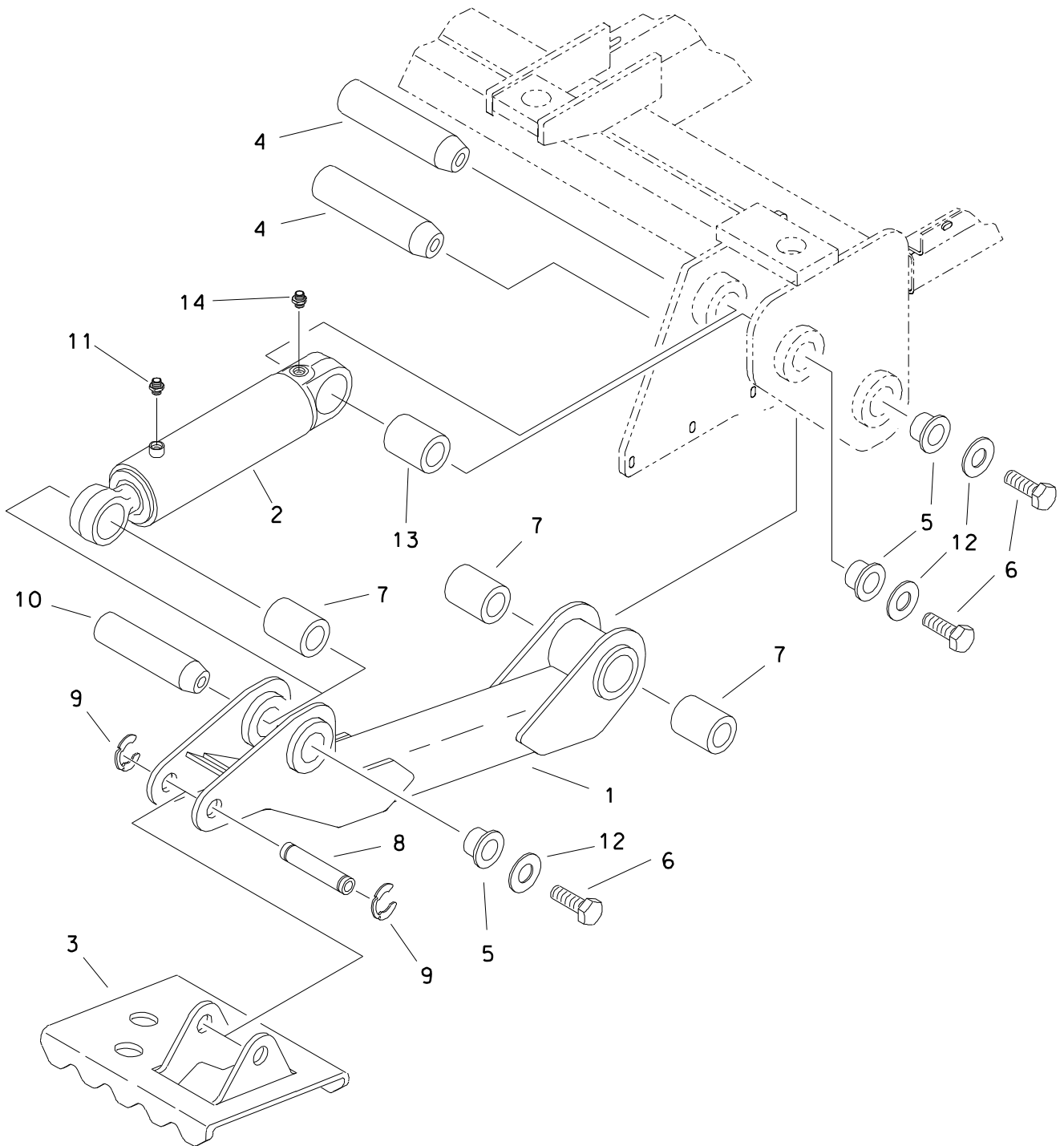

REAR STABILIZER

REF NO.	PART NUMBER	QTY	DESCRIPTION	REMARKS
1.	350-508	1	RIGHT STABILIZER	
	354-537	1	LEFT STABILIZER	
2.	151-187	2	CYLINDER ASSEMBLY	4" X 2" X 10"
3.	350-850	1	RIGHT STABILIZER PAD	
	354-536	1	LEFT STABILIZER PAD	
4.	179-223	4	TAPERED PIN (50.8mm X 208mm)	
5.	184-064	6	TAPERED INSERT (2")	
6.	106-798	6	SCREW (M20-2.50 X 55mm, 10.9)	
7.	125-754	6	COMPOSITION BUSHING (2")	
8.	179-224	2	PAD PIN	
9.	115-483	4	KLIP RING (1.25")	
10.	183-832	2	TAPERED PIN (50.8MM X 135MM)	
11.	154-261	2	CONNECTOR (040-08S)	
12.	106-399	6	WASHER (M20, HARDENED)	
13.	125-844	2	COMPOSITION BUSHING (2")	
14.	154-374	2	CONNECTOR (040-08S, DRF)	

FOOTNOTES

NOTES

REFER TO O-RING CHART (800-301) IN BACK OF BOOK FOR REPLACEMENT OF O-RINGS.

FUEL TANK

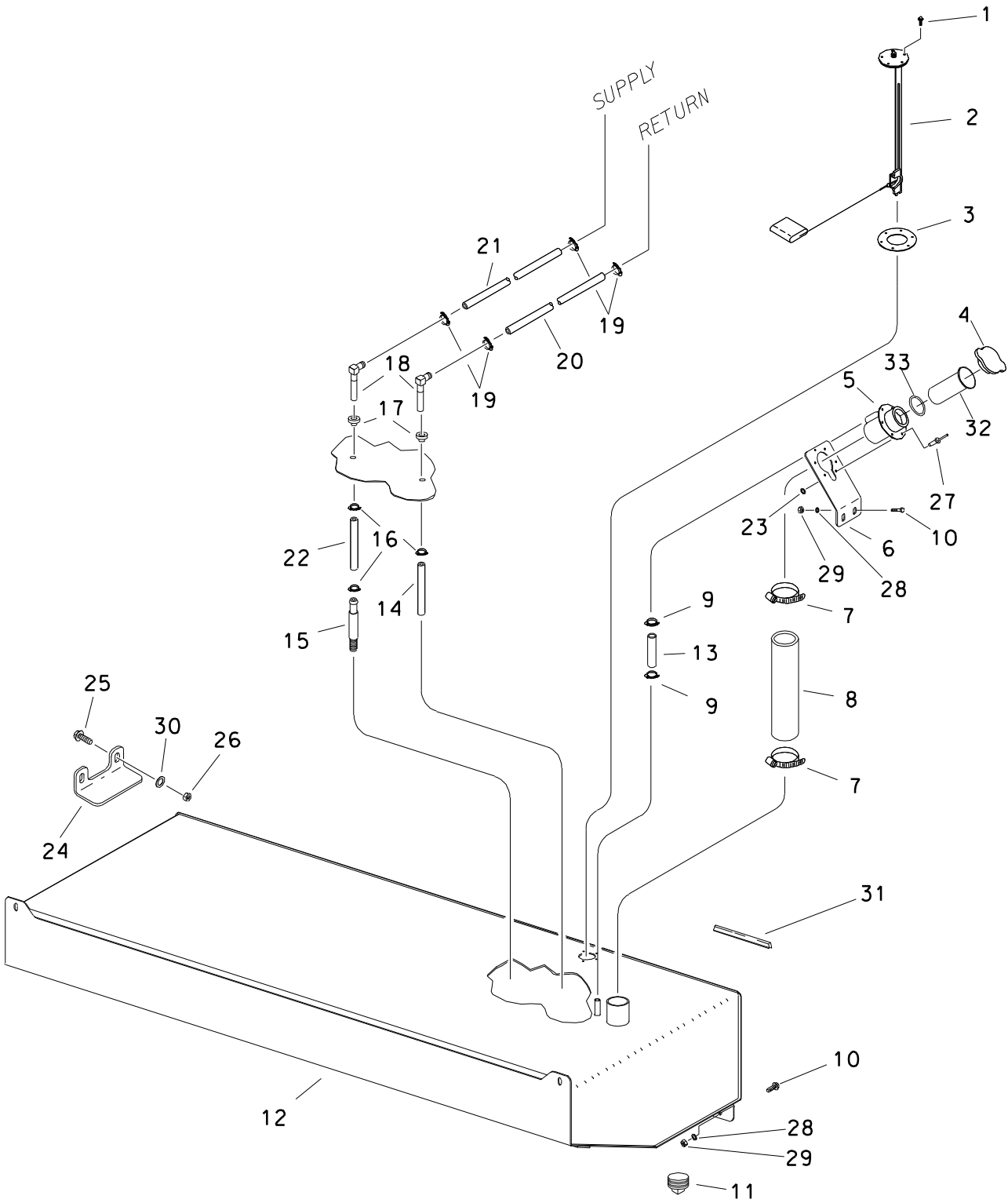

FUEL TANK

REF NO.	PART NUMBER	QTY	DESCRIPTION	REMARKS
1.	105-214	5	FLG SCREW (#10-24 X 1/2")	
2.	217-568	1	FUEL SENDER	
3.	165-704	1	GASKET	
4.	110-010	1	FUEL CAP (1-1/2")	
5.	364-080	1	FILLER NECK	
	364-659	1	FILLER NECK	
6.	364-487	1	FUEL FILL BRACKET	
7.	110-134	2	WORM CLAMP (2-1/16" TO 2-3/4")	
8.	116-721	1	FUEL HOSE (21")	
9.	110-217	2	WORM CLAMP (7/16" TO 1")	
10.	106-162	6	FLG SCREW (M8-1.25 X 20mm)	
11.	115-152	1	PLUG (12N, SQ, FM)	
12.	364-477	1	FUEL TANK	
13.	116-322	AR	BULK HOSE (1/2", SOLD PER 1')	USE 1 @ 22"
14.	118-096	AR	BULK FUEL TUBING (1/4", PER 1')	USE 1 @ 9"
15.	156-268	1	FUEL STRAINER (04H)	SEE FOOTNOTE 1
	194-505	1	FUEL PICKUP (04H)	BEGINS WITH S/N. SEE FOOTNOTE 1
16.	110-563	3	SPRING CLAMP (3/8")	
17.	116-325	2	GROMMET (.362")	SEE FOOTNOTE 1
18.	156-269	2	S/O COUPLER (04H-05H90)	BEGINS WITH S/N. SEE FOOTNOTE 1
19.	110-528	4	SNAP-ON CLAMP (.531" TO .593")	
20.	116-108	AR	BULK HOSE (5/16", SOLD PER 1')	USE 1 @ 78"
21.	116-108	AR	BULK HOSE (5/16", SOLD PER 1')	USE 1 @ 68"
22.	118-096	AR	BULK FUEL TUBING (1/4", PER 1')	USE 1 @ 7", SEE FOOTNOTE 1
23.	106-205	4	WASHER (.191")	INSTALL ON POP RIVET
24.	354-973	2	TANK CLAMP	
25.	106-632	4	FLG LK SCR (M12-1.75X35MM, SER)	
26.	106-685	4	LOCKNUT (M12-1.75, PRV TRQ, 10.9)	
27.	110-253	4	POP RIVET (3/16" X 1/2")	
28.	105-117	6	WASHER (5/16")	
29.	106-561	6	LOCKNUT (M8-1.25, PRV TRQ, 10.9)	
30.	106-391	4	WASHER (M12)	
31.	116-789	AR	RUBBER EDGE TRIM 1/8" (FT)	USE 1 @ 15", SEE FOOTNOTE 2
32.	364-663	1	FILLER NECK SCREEN	BEGINS WITH S/N.
33.	155-708	1	O-RING (218 D70)	BEGINS WITH S/N.

FOOTNOTES

- WHEN INSTALLING SUPPLY HOSE, INSTALL 116-325 ON SMALL PORTION OF LONG HOSE BARB OF 156-269 FIRST. INSTALL 7" HOSE 1.5" ONTO 156-269 AND FULLY ONTO 156-268. COMPLETED ASSEMBLY SHOULD MEASURE 10.8+/-0.1 FROM END TO END.
- START EDGING 8" FROM END OF TANK AND USE LOCTITE 401.

2-POST ROPS

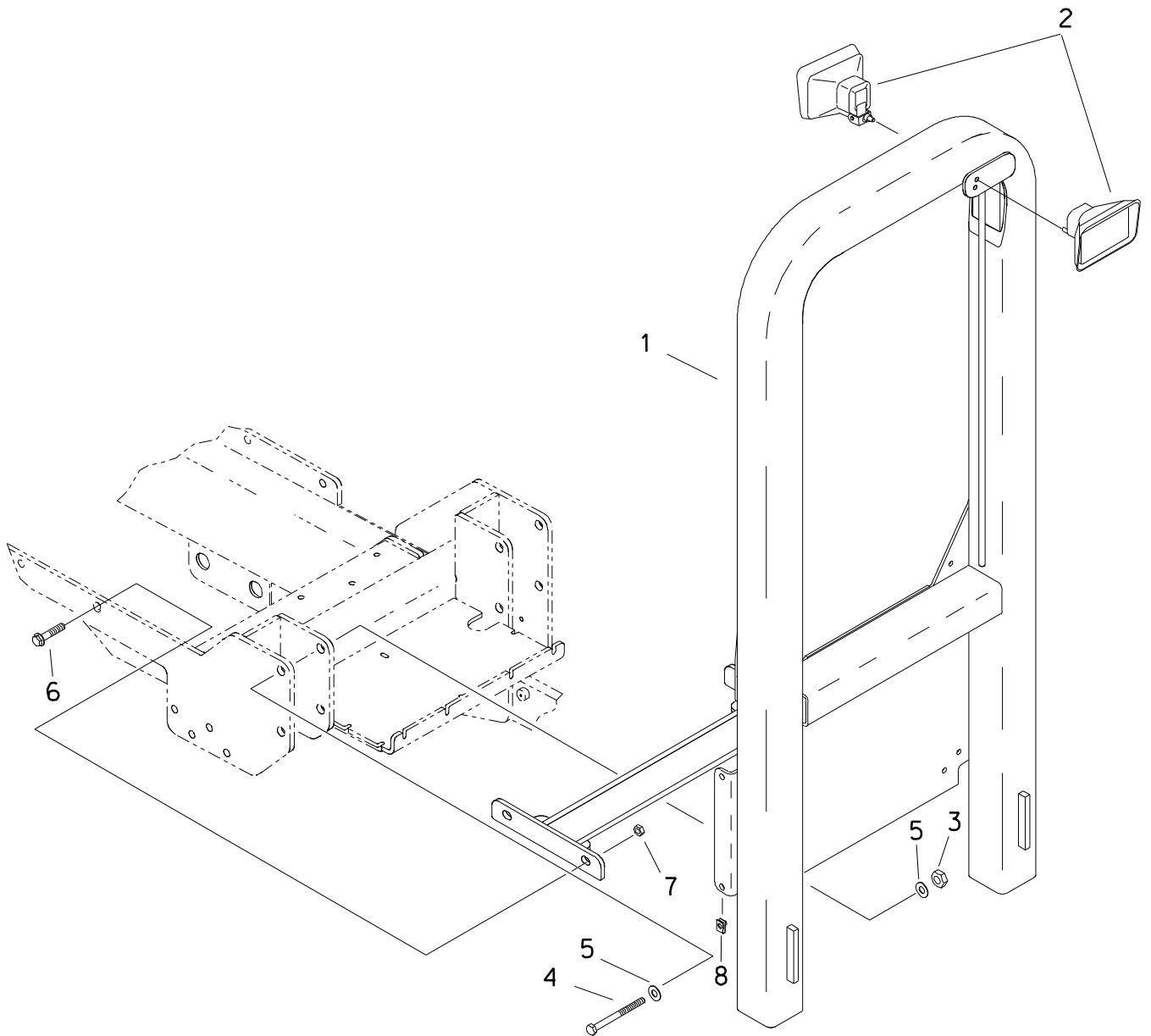

2-POST ROPS

REF NO.	PART NUMBER	QTY	DESCRIPTION	REMARKS
1.	309-190	1	2-POST ROPS	
2.	217-057	-	WORKING LIGHT - CLEAR	
-	105-033	1	BOLT (5/16-NC X 2")	
-	105-091	2	LOCK WASHER (5/16")	
-	105-092	2	NUT (5/16-NC)	
3.	106-665	4	LOCKNUT (M20-2.50, 10.9)	
4.	106-373	4	SCREW (M20-2.5 X 160mm)	
5.	106-399	8	WASHER (M20, HARDENED)	
6.	106-470	4	FLG SCREW (M16-2.00 X 40mm)	
7.	106-545	4	LOCKNUT (M16-2.00, PRV TRQ, 10.9)	
8.	107-687	4	CLIP NUT M8-1.25, LONG, WIDE	

FOOTNOTES

DRILLFRAME COVERS/LCKS/SWITCHES

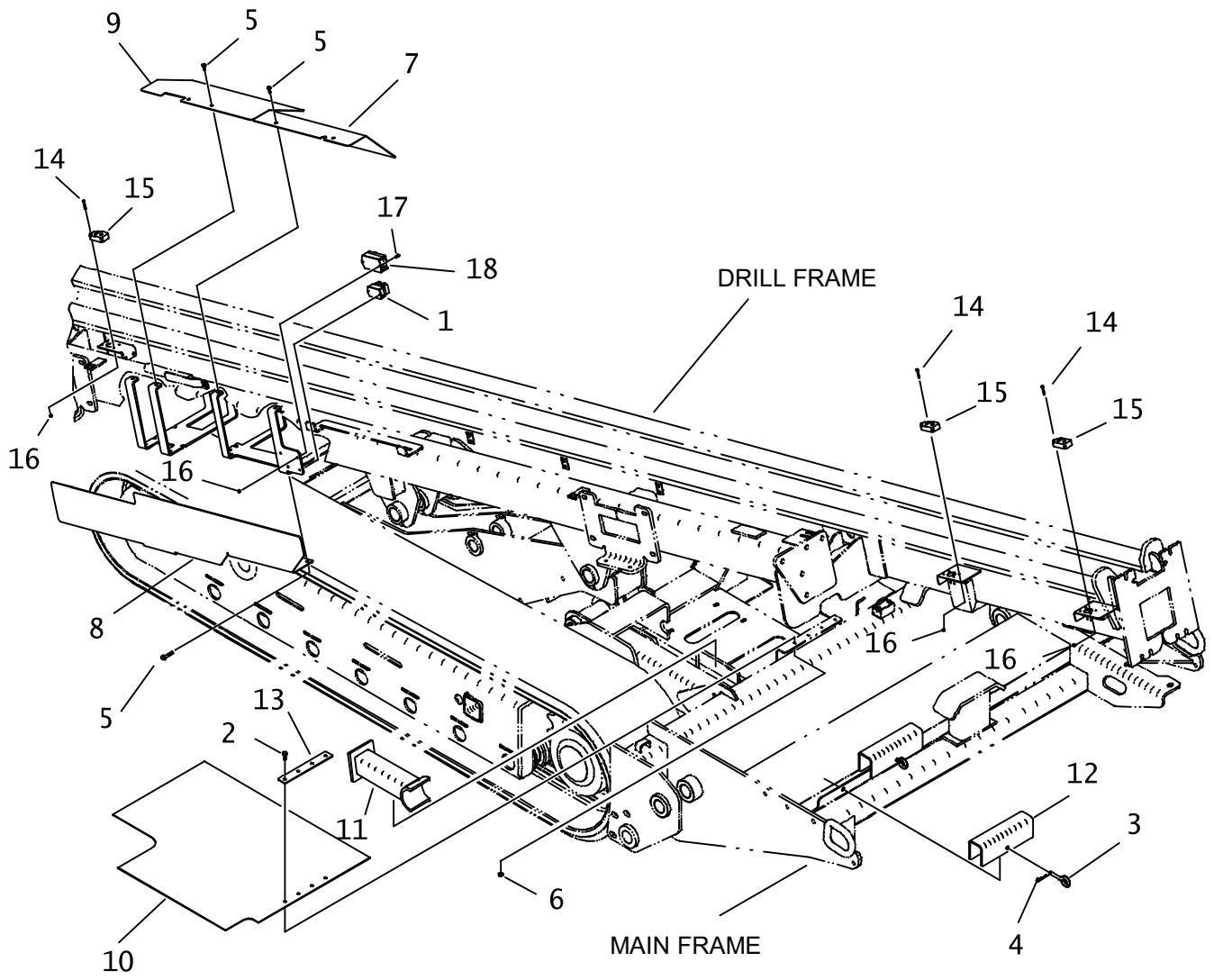

DRILLFRAME COVERS/LCKS/SWITCHES

REF NO.	PART NUMBER	QTY	DESCRIPTION	REMARKS
1.	211-026	1	DIODE PACK (DEUTSCH)	
2.	106-162	4	FLG SCREW (M8-1.25 X 20MM)	
3.	110-034	2	EYE PIN (7/16" X 3")	
4.	110-033	2	HAIR CLIP PIN (1/8" X ")	
5.	106-991	8	FLG LK SCREW (M8-1.25 X 20MM)	
6.	106-561	4	LOCKNUT (M8-1.25, PRV TRQ, 10.9)	
7.	305-948	1	VALVE COVER	
8.	305-949	1	VALVE COVER	
9.	305-947	1	VALVE COVER	
10.	116-863	1	COVER FLAP	
11.	354-562	1	DRILL FRAME STIFF LEG	
12.	354-980	2	CYLINDER LOCK	
13.	350-514	1	CLAMP PLATE	
14.	107-465	6	SCREW (M5-0.80 X 30MM, SOC)	
15.	215-1175	3	PROXIMITY SWITCH	
16.	106-850	10	LOCKNUT (M5-0.80)	
17.	106-542	4	SCREW (M5-0.80X16MM, PAN PLPS)	
18.	211-025	-	IN-LINE DIODE PACK	

NOT SHOWN:

107-451 AR SHIM (.135")
213-103 AT/JT42M1 REAR STOP HARNESS

FOOTNOTES:

NOTE:

HOSE RETAINING CLAMP

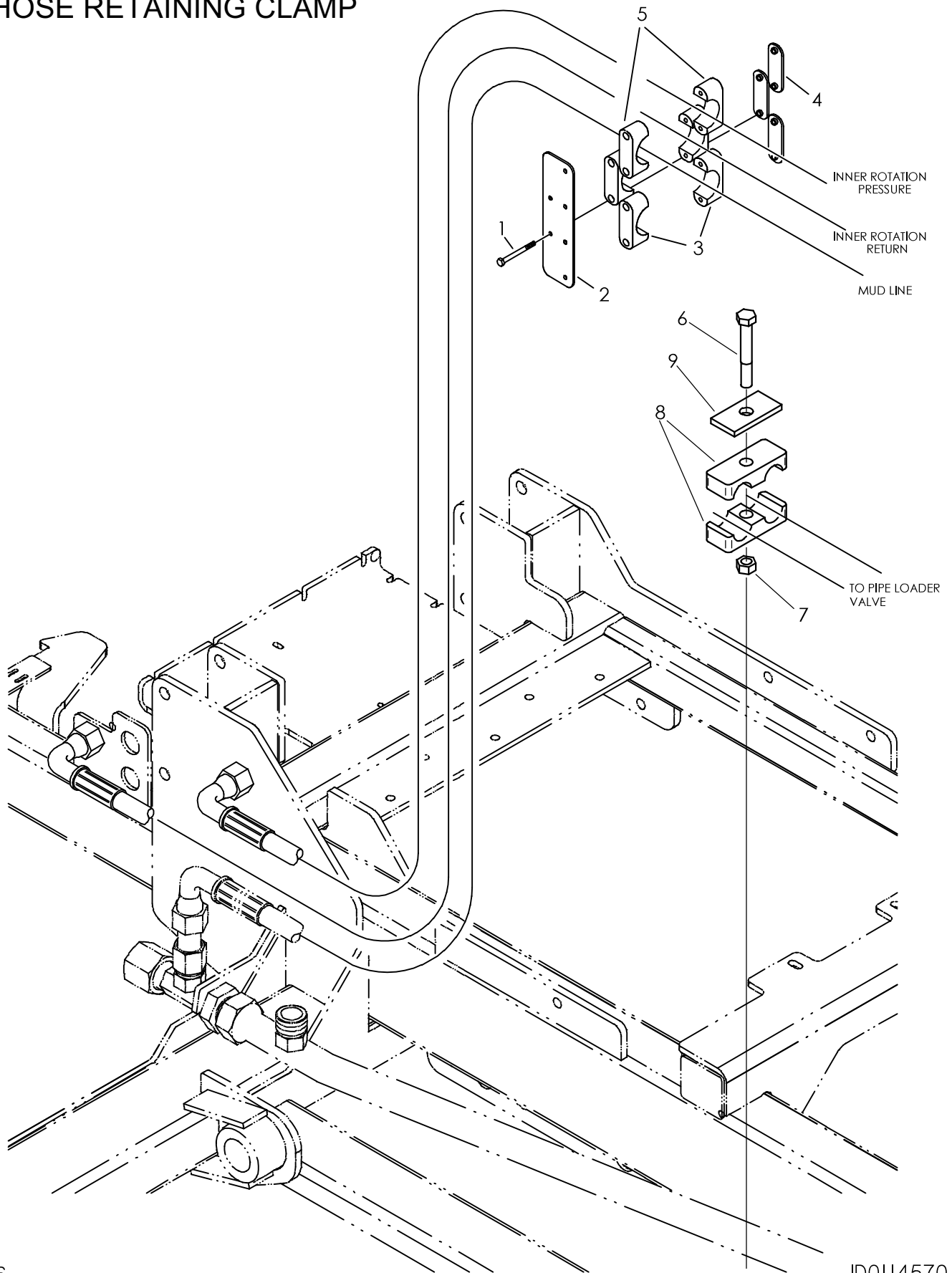

HOSE RETAINING CLAMP

REF NO.	PART NUMBER	QTY	DESCRIPTION	REMARKS
1.	107-743	6	SCREW (1/4-NC X 2.75", GD 5)	
2.	314-794	1	PLATE	
3.	110-970	2	CLAMP (2.00")	
4.	110-972	3	WELD PLATE	
5.	111-010	1	BLT-ON CLAMP(1.750", SET)	
6.	106-570	1	SCREW (M8-1.25 X 60MM)	FOOTNOTE I
7.	106-561	1	LOCKNUT (M8-1.25 PRV TRQ, 10.9)	FOOTNOTE I
8.	110-195	2	BOLT-ON CLAMP (3/4", PER HALF)	FOOTNOTE I
9.	305-256	1	BACKUP SPACER	FOOTNOTE I

NOT SHOWN:

FOOTNOTES:

- I. USE WITH RACK & PINION UNITS ONLY

NOTE:

ANCHOR SYSTEMS

AUGER ANCHOR BASE

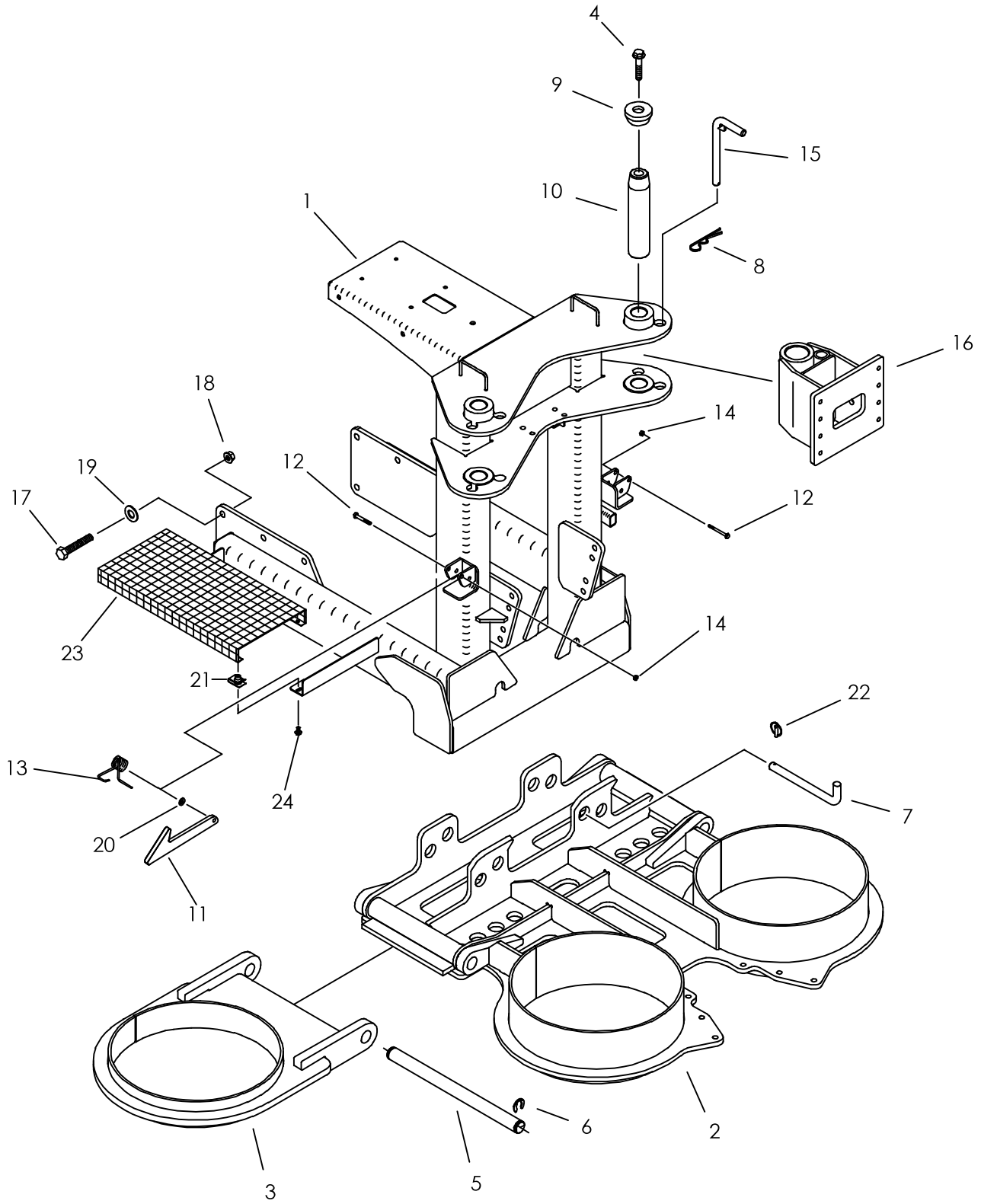

AUGER ANCHOR BASE

REF NO.	PART NUMBER	QTY	DESCRIPTION	REMARKS
1.	310-362	-	ANCHOR ATTACHMENT FRAME	
	327-1059	-	ANCHOR ATTACHMENT FRAME	SEE FOOTNOTE I
2.	313-592	1	ANCHOR BASE	
3.	343-548	2	PIVOT	
4.	106-470	2	FLG SCREW (M16-2.00 X 40mm)	
5.	184-973	2	PIN	
6.	115-483	4	KLIP RING (1.25")	
7.	343-445	2	PIN (31.75MM X 262MM)	
8.	110-128	2	SPRING CLIP PIN (5/32" X 1")	
9.	181-975	2	TAPERED INSERT (1.75")	
10.	179-239	2	TAPERED PIN (44.4mm X 288mm)	
11.	350-371	2	LATCH	
12.	106-332	4	SCREW (M10-1.50 X 70mm)	
13.	115-580	2	TORSION SPRING	
14.	105-894	4	LOCKNUT (M10-1.50,PRV TRQ, 10.9)	
15.	350-516	2	PIN	
16.	309-209	2	ARM	
17.	106-798	8	SCREW (M20-2.50 X 55MM, 10.9)	USE LOC TITE 242
18.	106-356	8	FLG LOCKNUT (M20-2.50,10.9,PRV TRQ)	
19.	106-399	8	WASHER (M20, HARDENED)	
20.	105-884	6	WASHER (.531")	
21.	106-551	4	CLIP NUT (M8-1.25)	
22.	110-228	2	LYNCH PIN (7/16" X 2")	
23.	350-989	1	FLOOR TREADS	
24.	106-991	4	FLG LK SCREW (M8-1.25 X 20MM)	

NOT SHOWN:

FOOTNOTES:

I. USE ON 4020 WITH RACK AND PINION

NOTE:

ANCHOR VALVE & COVER MOUNT

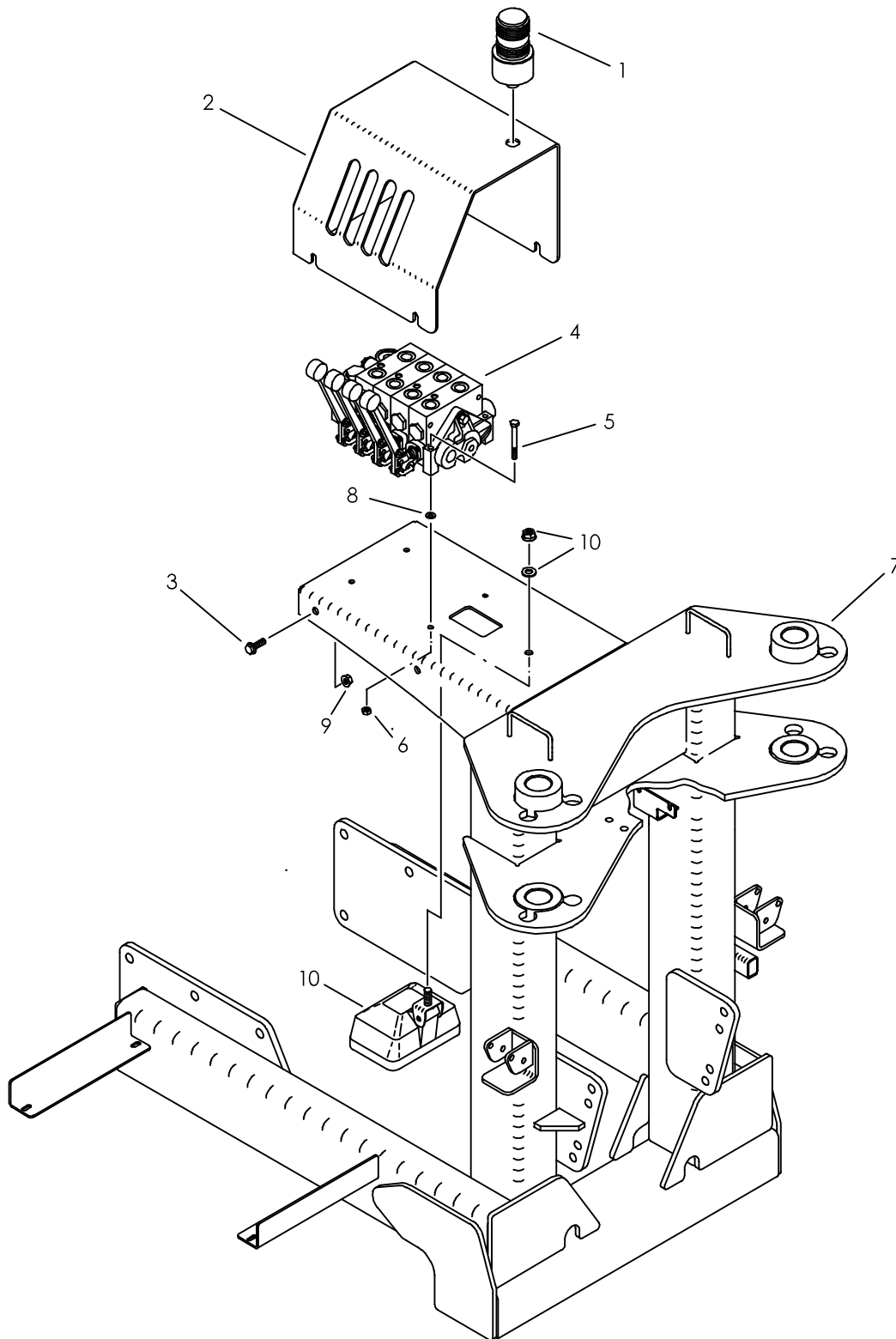

ANCHOR VALVE & COVER MOUNT

REF NO.	PART NUMBER	QTY	DESCRIPTION	REMARKS
1.	214-697	-	STROBE LIGHT (12V, DC, GREEN)	INSTALL ELECTRICAL PLUG AFTER MOUNTING LIGHT
	217-297	-	STROBE LIGHT GREEN MED PROFILE	
	214-103	1	2-WAY MALE CONNECTOR	
	214-991	-	REPLACEMENT FLASH TUBE	
	217-303	-	REPLACEMENT LENS (GREEN)	
	157-645	2	WEATHER-PAC SEAL (2.80MM)	
	214-104	2	PACKARD MALE TERMINAL	
	217-301	-	BRUSH GUARD	
2.	309-254	1	VALVE COVER	
3.	106-383	4	FLG LK SCREW (M10-1.50 X 30MM)	
4.	149-952	-	HYD CONTROL VALVE (4-SPOOL)	SEE FOOTNOTE I
5.	106-330	3	SCREW (M8-1.25 X 70MM)	
6.	106-561	3	LOCKNUT (M8-1.25,PRV TRQ,10.9)	
7.	310-362	-	ANCHOR ATTACHMENT FRAME	
	327-1059	-	ANCHOR ATTACHMENT FRAME	
8.	106-389	3	WASHER (M8)	
9.	106-387	4	FLG LOCKNUT (M10-1.50)	
10.	217-007	1	WORKING LIGHT (CLEAR, RECT)	

NOT SHOWN:

FOOTNOTES:

I. USE ON 4020 WITH RACK AND PINION.

NOTE:

FRONT PIPE GUIDE. ALL TERRAIN ONLY

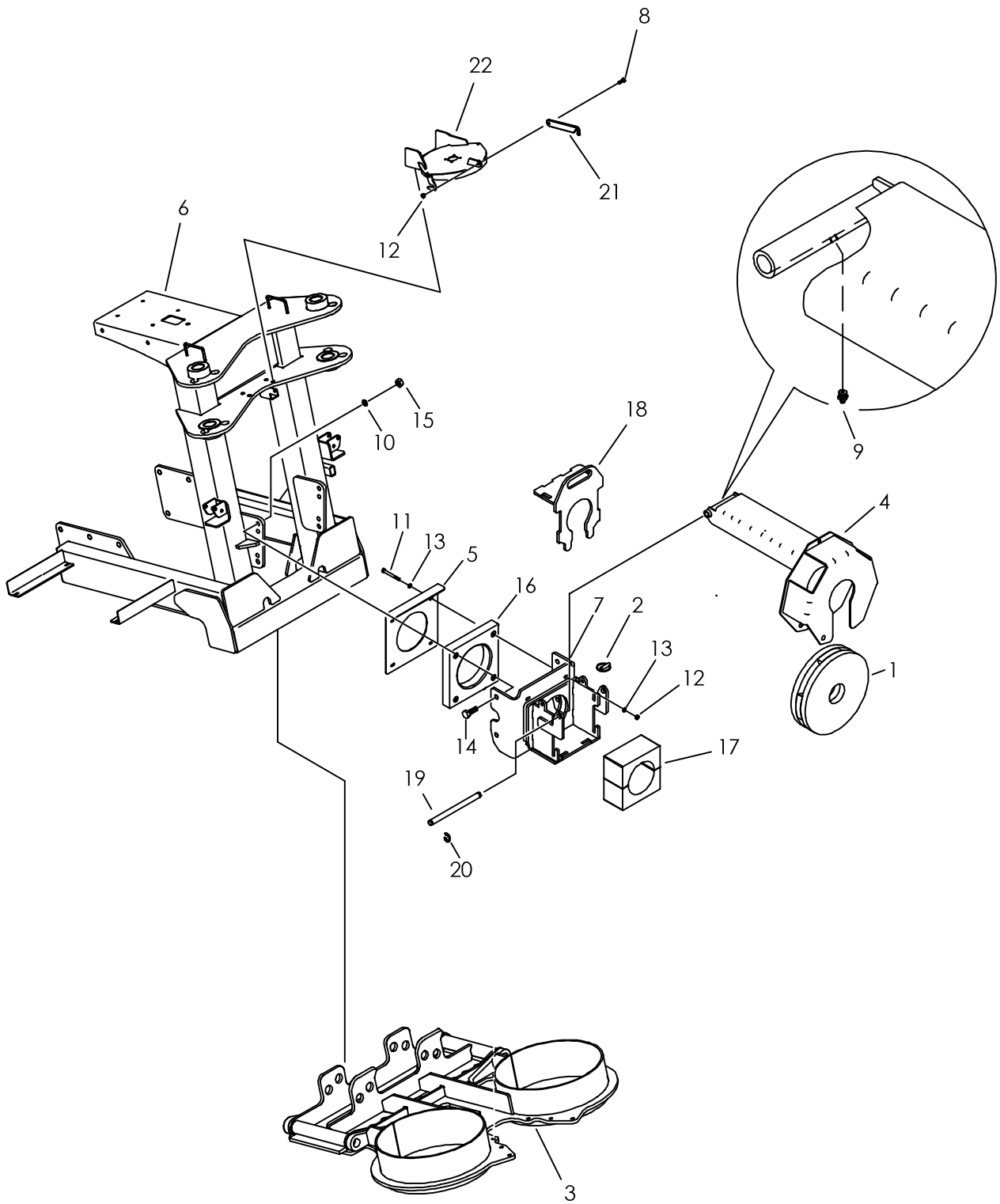

FRONT PIPE GUIDE. ALL TERRAIN ONLY

REF NO.	PART NUMBER	QTY	DESCRIPTION	REMARKS
1.	157-196	1	ROD WIPER	
2.	110-228	2	LYNCH PIN (7/16" X 2")	
3.	313-592	1	ANCHOR BASE	
4.	314-732	1	WIPER MOUNT	
5.	310-366	1	COVER	
6.	310-362	1	ANCHOR ATTACHMENT FRAME	
	327-1059	1	ANCHOR ATTACHMENT FRAME	SEE FOOTNOTE I
7.	319-747	1	GUIDE BEARING MOUNT	
8.	106-381	1	FLG LK SCREW (M8-1.25 X 25MM)	
9.	115-003	1	ZERK (1/4-NF, STR)	
10.	106-397	4	WASHER (M12, HARDENED)	
11.	106-602	4	SCREW (M8-1.25 X 80MM)	
12.	106-561	5	LOCKNUT (M8-1.25, PRV TRQ, 10.9)	
13.	105-117	8	WASHER (5/16")	
14.	107-307	4	BOLT (M12-1.75 X 45MM)	
15.	106-685	4	LOCKNUT (M12-1.75, PRV TRQ, 10.9)	
16.	211-084	1	CURRENT TRANSFORMER	
17.	314-359	2	GUIDE BLOCK (4.13)	
18.	314-387	1	BLOCK RETAINER	
19.	178-863	1	PIVOT PIN	
20.	115-503	2	KLIP RING (.750")	
21.	314-744	1	HOOK	
22.	350-400	-	COVER	

NOT SHOWN:

214-542	CURRENT COIL CABLE
211-042	VOLTAGE LIMITER
215-799	VOLTAGE STAKE

FOOTNOTES:

I. USE ON 4020 WITH RACK AND PINION. USE UPPER SET OF HOLES TO MOUNT 319-747.

NOTE:

FRONT PIPE GUIDE

JT 4020 MACH 1 ONLY

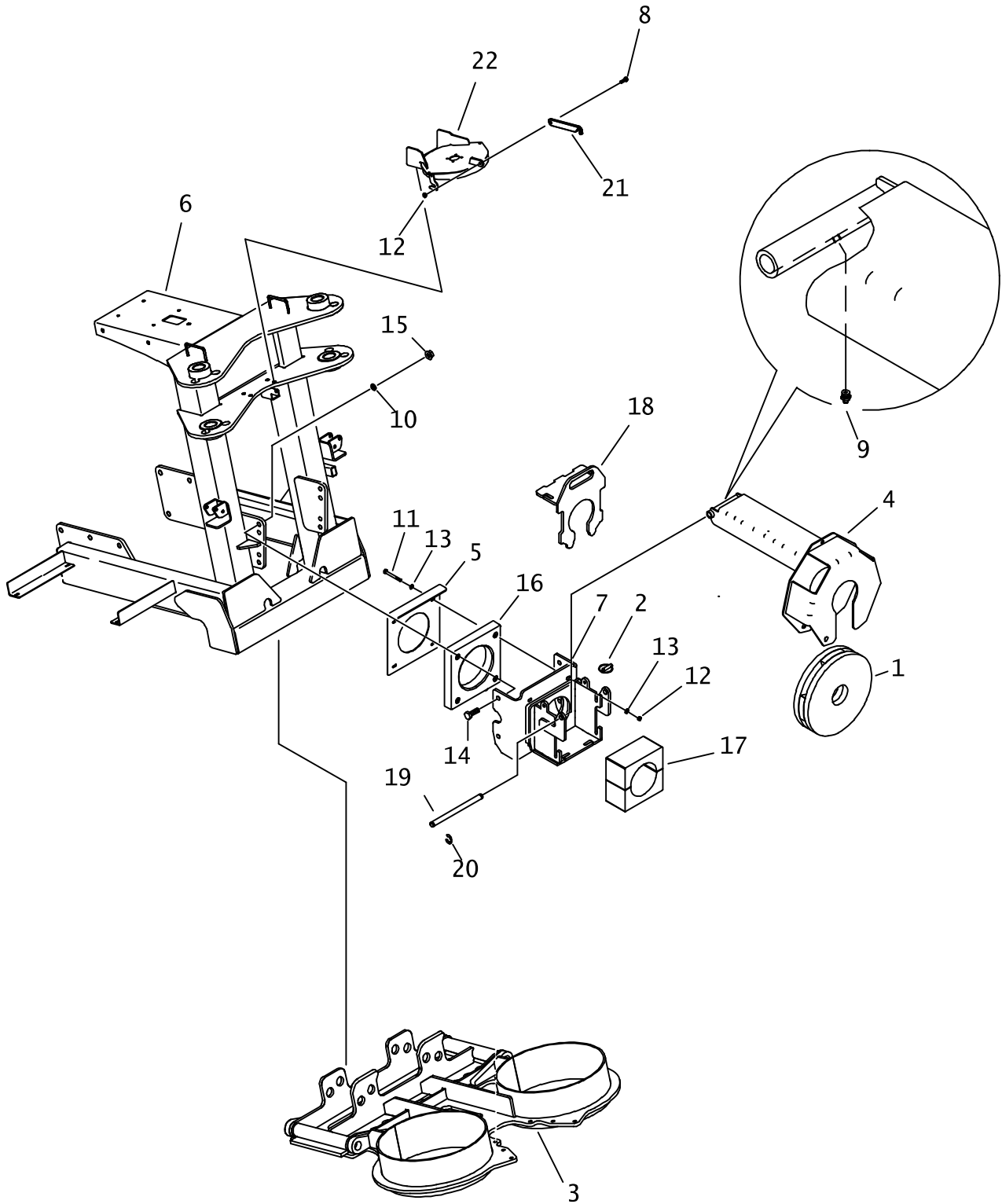

FRONT PIPE GUIDE JT 4020 MACH 1 ONLY

REF NO.	PART NUMBER	QTY	DESCRIPTION	REMARKS
1.	117-627	1	ROD WIPER	
2.	110-228	2	LYNCH PIN (7/16" X 2")	
3.	313-592	1	ANCHOR BASE	
4.	314-732	1	WIPER MOUNT	
5.	310-366	1	COVER	
6.	310-362	1	ANCHOR ATTACHMENT FRAME	
	327-1059	1	ANCHOR ATTACHMENT FRAME	SEE FOOTNOTE I
7.	319-747	1	GUIDE BEARING MOUNT	
8.	106-381	1	FLG LK SCREW (M8-1.25 X 25MM)	
9.	115-003	1	ZERK (1/4-NF, STR)	
10.	106-397	4	WASHER (M12, HARDENED)	
11.	106-602	4	SCREW (M8-1.25 X 80MM)	
12.	106-561	5	LOCKNUT (M8-1.25, PRV TRQ, 10.9)	
13.	105-117	8	WASHER (5/16")	
14.	107-307	4	BOLT (M12-1.75 X 45MM)	
15.	106-685	4	LOCKNUT (M12-1.75, PRV TRQ, 10.9)	
16.	211-084	1	CURRENT TRANSFORMER	
17.	314-360	2	GUIDE BLOCK (3.50)	
18.	314-387	1	BLOCK RETAINER	
19.	178-863	1	PIVOT PIN	
20.	115-503	2	KLIP RING (.750")	
21.	314-744	1	HOOK	
22.	350-400	-	COVER	

NOT SHOWN:

214-542	CURRENT COIL CABLE
211-042	VOLTAGE LIMITER
215-799	VOLTAGE STAKE

FOOTNOTES:

USE ON 4020 WITH RACK AND PINION.

NOTE:

RIGHT AUGER ANCHOR DRIVE

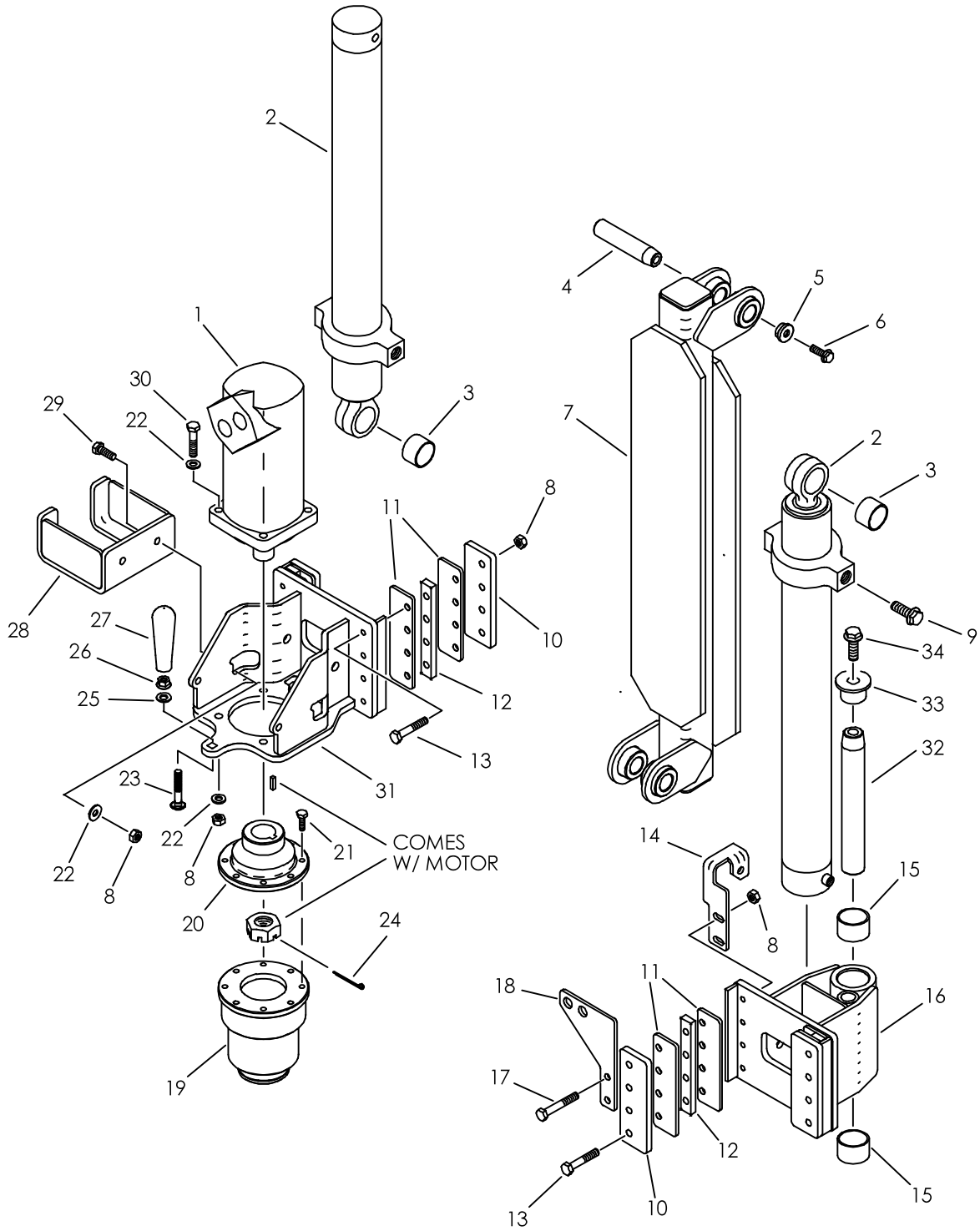

RIGHT AUGER ANCHOR DRIVE

REF NO.	PART NUMBER	QTY	DESCRIPTION	REMARKS
1.	149-895	1	HYD MOTOR	
	500-390		SEAL REPAIR KIT - REAR	
	500-391		SEAL REPAIR KIT - SHAFT	
	502-177		SHAFT AND BEARING ASS'Y	
	107-792		BOLT (5/16"X 1-5/8", DBL HEX)	
	165-900		KEY (7/16" SQ X 1.250")	
	105-917		CASTLE NUT (1-1/4-NF)	SEE FOOTNOTE 1
	500-2123		FRONT RETAINER (ANCHOR MOTOR)	
2.	150-747	2	CYLINDER ASSEMBLY	
3.	125-771	2	COMPOSITION BUSHING (1.25")	
4.	183-765	2	TAPERED PIN (31.7MM X 110MM)	
5.	181-982	2	TAPERED INSERT (1.25")	
6.	106-469	2	FLG SCREW (M12-1.75 X 30MM)	USE LOCTITE 242
7.	359-799	1	MAST	
8.	106-685	23	LOCKNUT(M12-1.75,PRV TRQ,10.9)	
9.	106-471	4	FLG SCREW (M16-2.00 X 30MM)	USE LOCTITE 242
10.	309-194	4	CLAMP PLATE	
11.	309-195	8	GLIDE STRIP	
12.	309-203	4	CARRIAGE SPACER BAR	
13.	106-335	14	SCREW (M12-1.75 X 70MM)	
14.	309-205	1	BULKHEAD PLATE	
15.	125-773	2	COMPOSITION BUSHING (1.75")	
16.	309-209	1	ARM	
17.	106-700	2	SCREW (M12-1.75 X 80MM)	
18.	309-204	1	BULKHEAD PLATE	
19.	309-582	-	FLANGED HEX DRIVER	
20.	178-881	1	FLANGE	
21.	105-245	8	SCREW (M10-1.50 X 25MM)	USE LOCTITE 242
22.	106-397	9	WASHER (M12, HARDENED)	
23.	105-279	1	CARRIAGE BOLT (1/2-NC X 3")	
24.	105-501	1	COTTER PIN (1/8" X 2")	
25.	105-071	1	WASHER (1/2")	
26.	105-833	1	FLG LOCKNUT (1/2-NC)	
27.	110-531	1	HANDLE (1/2-NC, BLACK)	USE LOCTITE 242
28.	309-602	1	ANCHOR HANGER	
29.	106-333	2	SCREW (M12-1.75 X 40MM, 8.8)	
30.	106-594	4	SCREW (M12-1.75 X 60MM)	
31.	309-207	1	MOTOR MOUNT	
32.	179-239	1	TAPERED PIN (44.4MM X 288MM)	
33.	181-975	1	TAPERED INSERT (1.75")	
34.	106-470	1	FLG SCREW (M16-2.00 X 40MM)	USE LOCTITE 242

NOT SHOWN:

FOOTNOTES:

- I. TORQUE NUT TO 375 FT. LB. DRY OR 275 FT. LB. LUBED

NOTE:

LEFT AUGER ANCHOR DRIVE

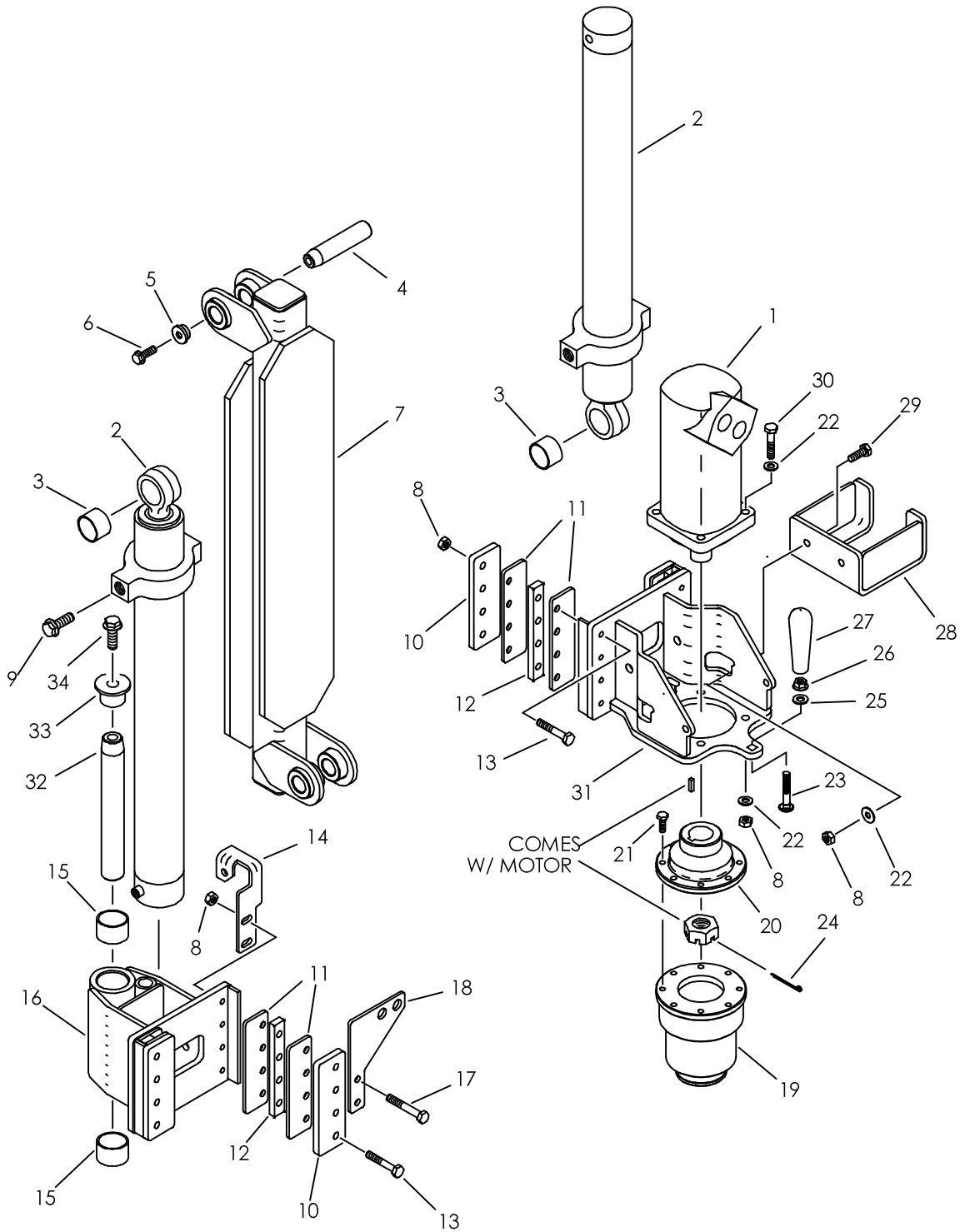

LEFT AUGER ANCHOR DRIVE

REF NO.	PART NUMBER	QTY	DESCRIPTION	REMARKS
1.	149-895	1	HYD MOTOR	
	500-390		SEAL REPAIR KIT - REAR	
	500-391		SEAL REPAIR KIT - SHAFT	
	502-177		SHAFT AND BEARING ASS'Y	
	107-792		BOLT (5/16" X 1-5/8", DBL HEX)	
	165-900		KEY (7/16" SQ X 1.250")	
	105-917		CASTLE NUT (1-1/4-NF)	SEE FOOTNOTE 1
	500-2123		FRONT RETAINER (ANCHOR MOTOR)	
2.	150-747	2	CYLINDER ASSEMBLY	
3.	125-771	2	COMPOSITION BUSHING (1.25")	
4.	183-765	2	TAPERED PIN (31.7MM X 110MM)	
5.	181-982	2	TAPERED INSERT (1.25")	
6.	106-469	2	FLG SCREW (M12-1.75 X 30MM)	USE LOCTITE 242
7.	359-799	1	MAST	
8.	106-685	23	LOCKNUT(M12-1.75,PRV TRQ,10.9)	
9.	106-471	4	FLG SCREW (M16-2.00 X 30MM)	USE LOCTITE 242
10.	309-194	4	CLAMP PLATE	
11.	309-195	8	GLIDE STRIP	
12.	309-203	4	CARRIAGE SPACER BAR	
13.	106-335	14	SCREW (M12-1.75 X 70MM)	
14.	309-206	1	BULKHEAD PLATE	
15.	125-773	2	COMPOSITION BUSHING (1.75")	
16.	309-209	1	ARM	
17.	106-700	2	SCREW (M12-1.75 X 80MM)	
18.	309-204	1	BULKHEAD PLATE	
19.	309-582	-	FLANGED HEX DRIVER	
20.	178-881	1	FLANGE	
21.	105-245	8	SCREW (M10-1.50 X 25MM)	USE LOCTITE 242
22.	106-397	9	WASHER (M12, HARDENED)	
23.	105-279	1	CARRIAGE BOLT (1/2-NC X 3")	
24.	105-501	1	COTTER PIN (1/8" X 2")	
25.	105-071	1	WASHER (1/2")	
26.	105-833	1	FLG LOCKNUT (1/2-NC)	
27.	110-531	1	HANDLE (1/2-NC, BLACK)	USE LOCTITE 242
28.	309-602	1	ANCHOR HANGER	
29.	106-333	2	SCREW (M12-1.75 X 40MM, 8.8)	
30.	106-594	4	SCREW (M12-1.75 X 60MM)	
31.	309-207	1	MOTOR MOUNT	
32.	179-239	1	TAPERED PIN (44.4MM X 288MM)	
33.	181-975	1	TAPERED INSERT (1.75")	
34.	106-470	1	FLG SCREW (M16-2.00 X 40MM)	USE LOCTITE 242

NOT SHOWN:

FOOTNOTES:

1. TORQUE NUT TO 375 FT. LB. DRY OR 275 FT. LB. LUBED

NOTE:

FLANGED HEX DRIVER ASS'Y

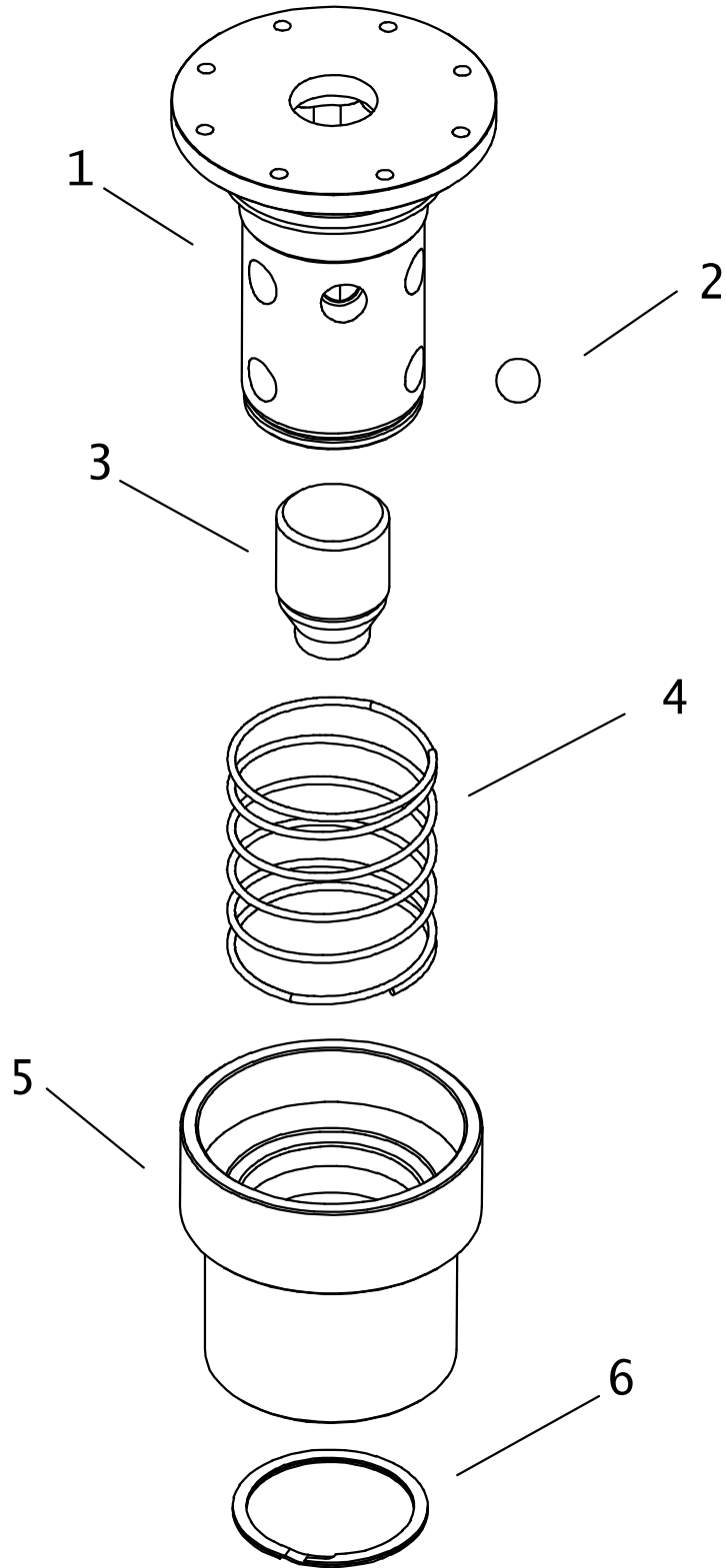

FLANGED HEX DRIVER ASS'Y

REF NO.	PART NUMBER	QTY	DESCRIPTION	REMARKS
	309-582		FLANGED HEX DRIVER	INCLUDEDS REF NO. 1-6
1.	309-093	1	ANCHOR DRIVER	FOOTNOTE 2
2.	125-150	9	DETENT BALL (.875")	
3.	309-095	1	WEIGHT STOP	
4.	117-160	1	COMPRESSION RING	
5.	178-591	1	LOCK COLLAR	
6.	118-054	1	EXTERNAL SNAP RING	
	116-761	1	SPIRAL RETAINING RING	FOOTNOTE 1

NOT SHOWN:

FOOTNOTES:

1. USE WHEN INSTALLING UPDATED 309-093
2. UPDATED VERSION NECKED-DOWN FOR THICKER 116-761

NOTE:

ANCHOR

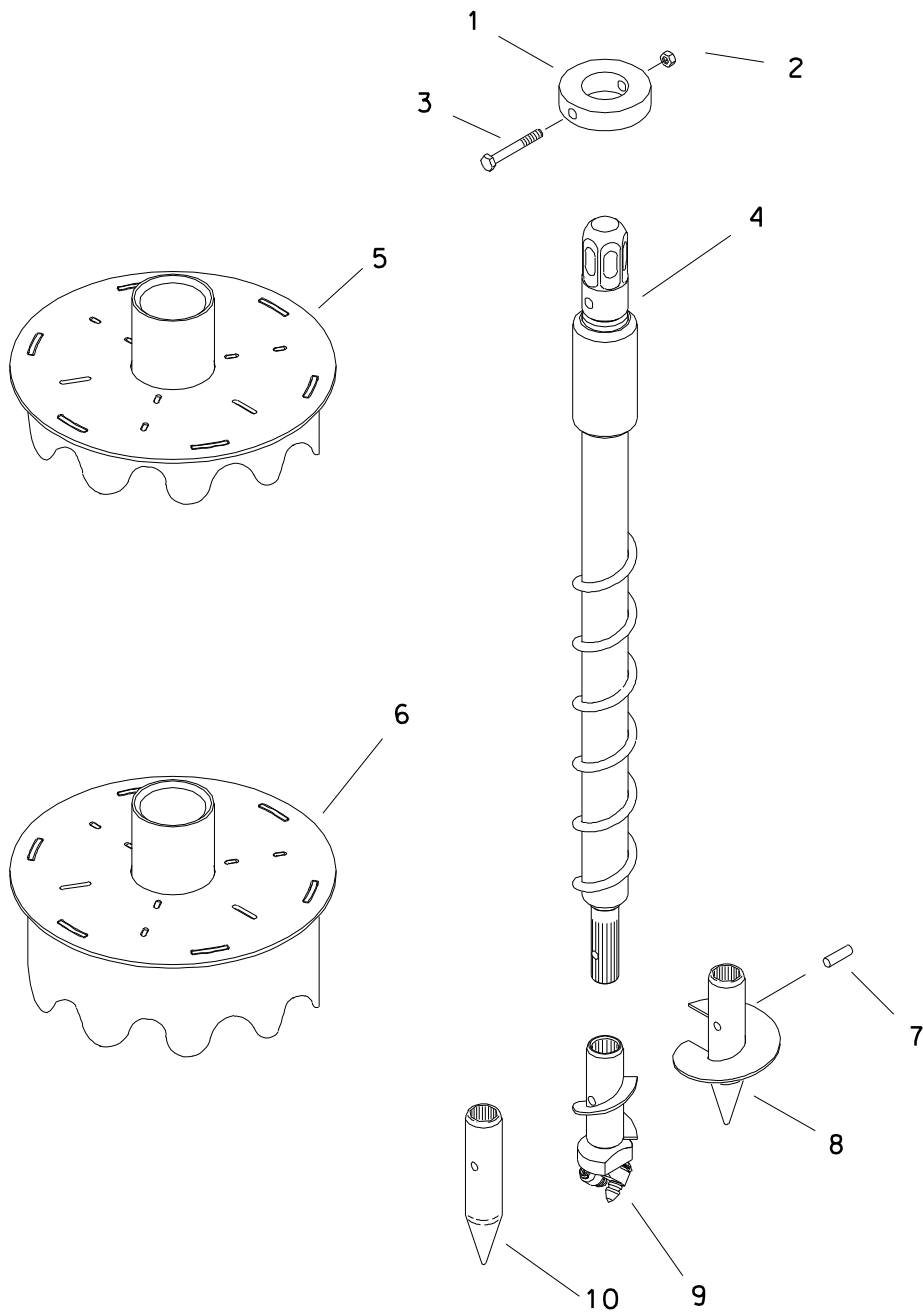

ANCHOR

REF NO.	PART NUMBER	QTY	DESCRIPTION	REMARKS
	309-250	-	ANCHOR SHAFT	INCL REF NO'S 1-4
1.	178-513	1	COLLAR	
2.	106-685	1	LOCKNUT (M12-1.75, PRV TRQ, 10.9)	
3.	106-645	1	SCREW (M12-1.75 X 110MM, 10.9)	
4.	308-902	1	ANCHOR STAKE	
5.	309-750	1	CENTERING CAP	SHORT - USED IN SIDE POSITIONS
6.	308-903	1	CENTERING CAP	TALL - USED IN FRONT POSITIONS
7.	183-860	AR	ROLL PIN (1/2" X 1-7/8")	
8.	356-366	AR	AUGER (150MM)	
	356-365	AR	AUGER (225MM)	
	356-364	AR	AUGER (380MM)	
9.	369-438	AR	3.5" CAP ANCHOR BIT	ROCK BITS
	136-113	-	INSERT BIT - CARBIDE TIPPED	REPLACEMENT BIT FOR 369-438
	131-259	-	INSERT BIT - CARBIDE TIPPED	
	136-112	-	CLIP RETAINER	REPLACEMENT CLIP FOR 369-438
10.	357-330	AR	STAKE POINT	DIRT BITS

FOOTNOTES

LUBRICATOR

GREASE PUMP MOUNTING

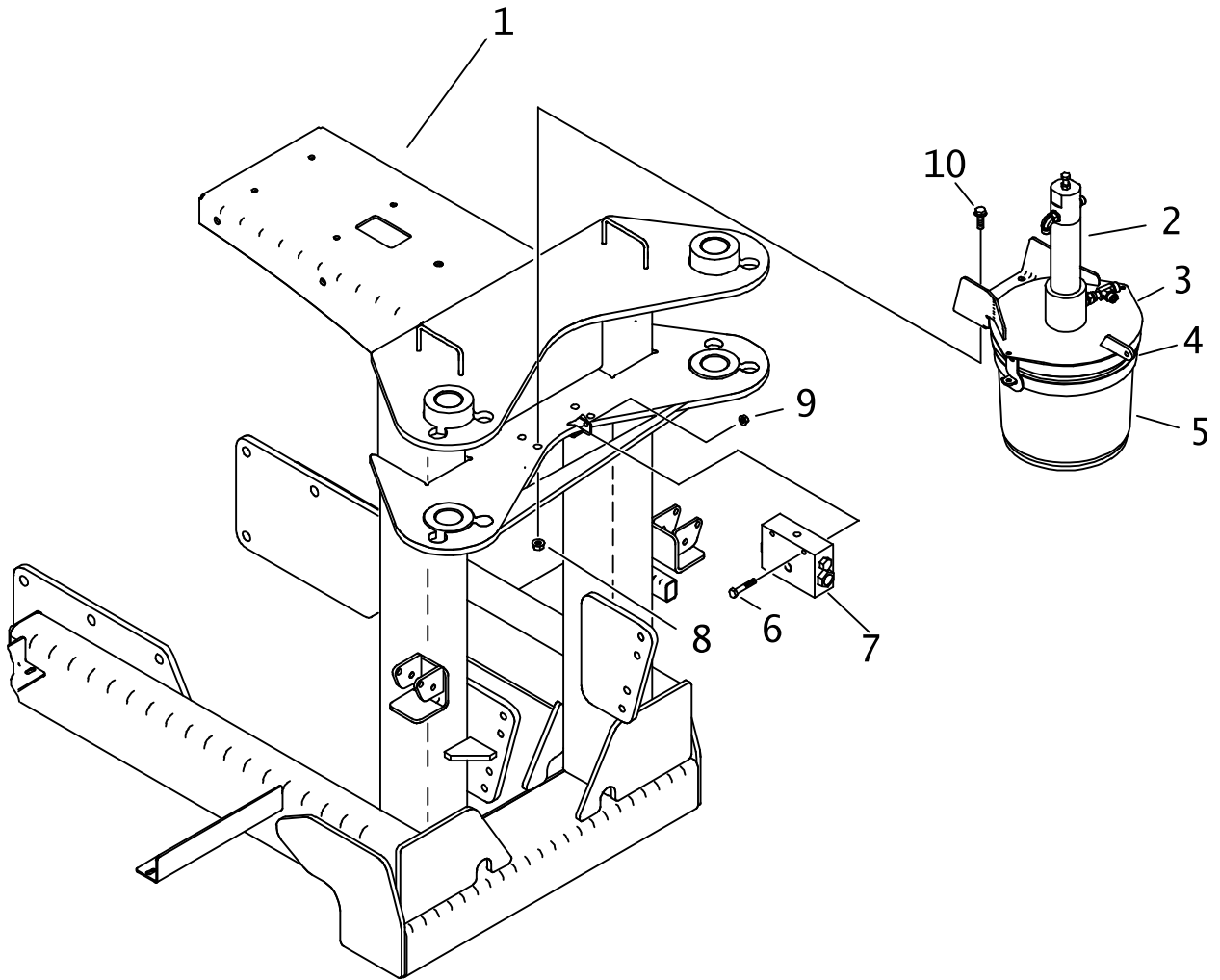

GREASE PUMP MOUNTING

REF NO.	PART NUMBER	QTY	DESCRIPTION	REMARKS
1.	310-362	-	ANCHOR ATTACHMENT FRAME	
	327-1059	-	ANCHOR ATTACHMENT FRAME	SEE FOOTNOTE I
2.	350-398	-	GREASE PUMP	
3.	350-400	-	COVER	
4.	350-399	-	BASE	
5.	259-858	-	TOOL JNT LUBE, STD SPRY 2 GAL	USE BELOW 80 DEG F MAX TEMP
	256-031	-	TOOL JNT LUBE, SUMR SPRY 2 GAL	USE ABOVE 50 DEG F MIN TEMP
6.	106-570	2	SCREW (M8-1.25 X 60MM)	
7.	310-591	1	VALVE ASS'Y	
8.	106-387	4	FLG LOCKNUT (M10-1.50)	
9.	106-386	2	FLG LOCKNUT (M8-1.25)	
10.	106-383	4	FLG LK SCREW (M10-1.50 X 30MM)	

NOT SHOWN:

FOOTNOTES:

USE ON 4020 WITH RACK AND PINION

NOTE:

AUTO-LUBER ASSEMBLY

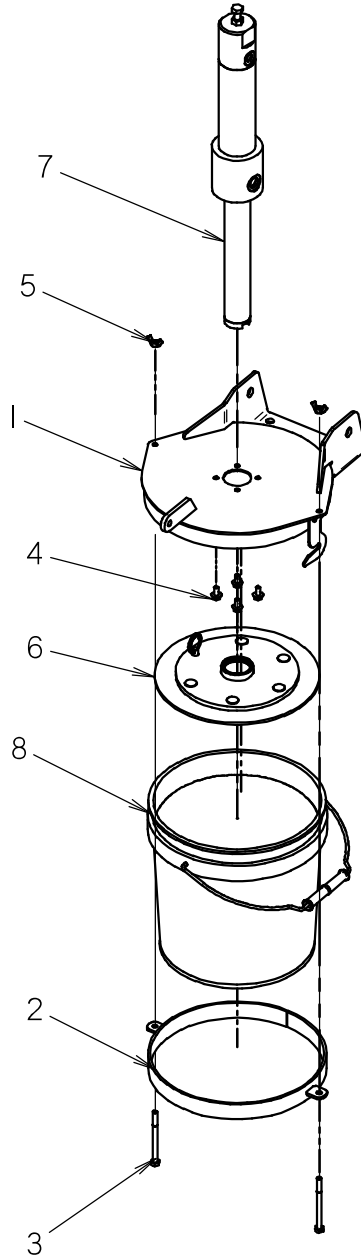

AUTO-LUBER ASSEMBLY

REF NO.	PART NUMBER	QTY	DESCRIPTION	REMARKS
1	350-400	1	COVER WELDMENT	
2	350-399	1	BASE	
3	105-297	2	BOLT (1/4-NC X 3-1/4")	
4	106-378	4	FLG LK SCREW (M6-1.00 X 12MM)	
5	195-339	2	WING NUT (1/4-NC)	
6	350-1932	1	TOOL JOINT LUBE FOLLOWER	
7	350-398	1	GREASE PUMP PARTS	
8	259-858	1	TOOL JNT LUBE, STD SPRY 2 GAL	
	256-031	-	TOOL JNT LUBE, SUMR SPRY 2 GAL	

NOT SHOWN:

FOOTNOTES:

NOTE:

GREASE PUMP

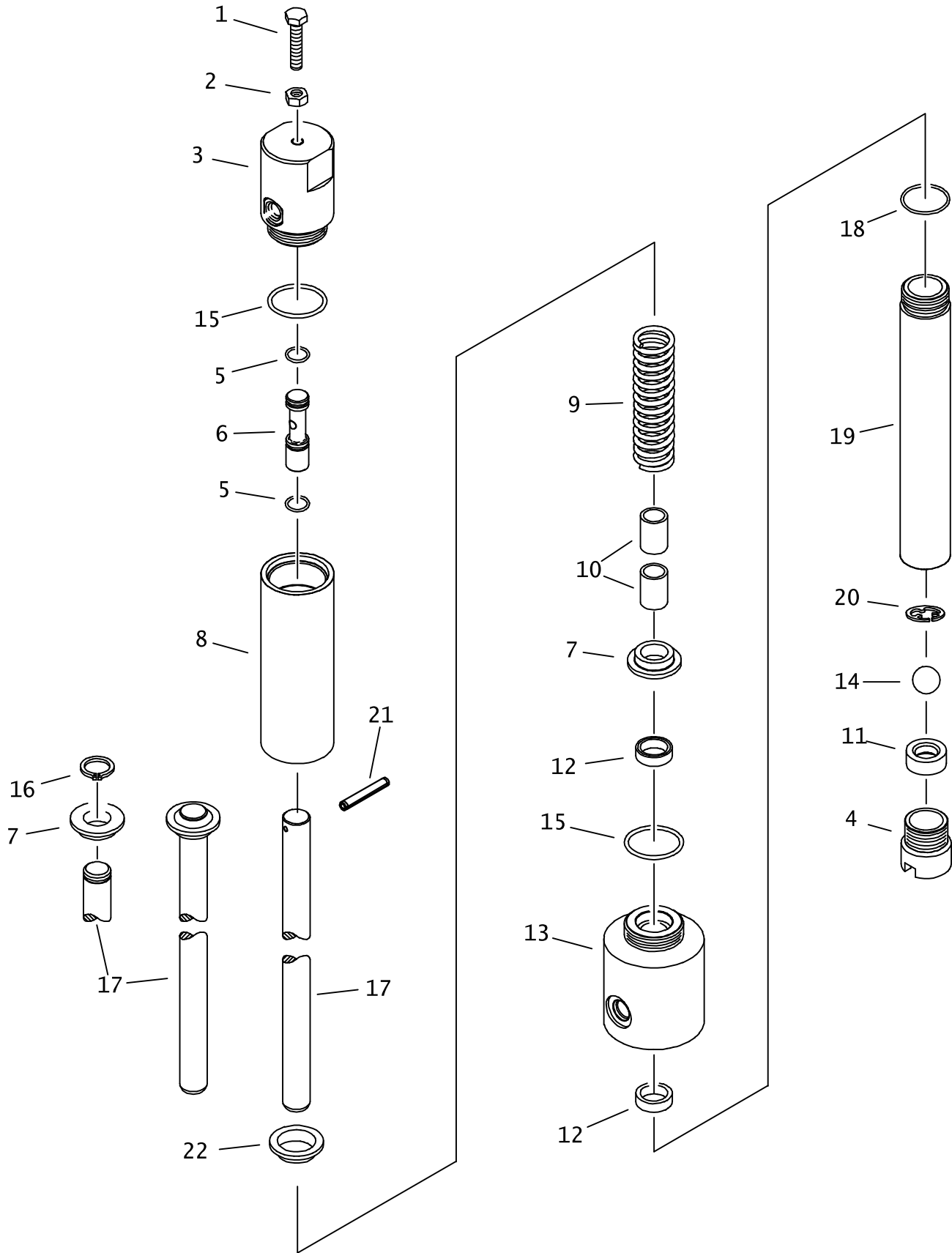

GREASE PUMP

REF NO.	PART NUMBER	QTY	DESCRIPTION	REMARKS
	350-398		GREASE PUMP PARTS	INCL REF NO'S 1-20
1.	107-492	1	SCREW (M8-1.25 X 35MM, ALL THD)	
2.	106-078	1	NUT (M8-1.25)	
3.	350-686	1	CYLINDER CAP	
4.	350-692	1	INLET TUBE	
5.	157-049	2	O-RING (113 D70)	
6.	350-421	1	ADJUSTING SPOOL	
7.	350-671	1	ROD GUIDE	SEE FOOTNOTE 2
8.	350-682	1	BARREL	
9.	117-228	1	COMPRESSION SPRING	
10.	125-424	2	BRONZE BUSHING (.750")	
11.	350-691	1	VALVE SEAT	SEE FOOTNOTE 1
12.	117-227	2	SEAL (POLY PAK)	
13.	350-687	1	PUMP BODY	
14.	125-125	1	DETENT BALL (.750")	
15.	155-702	2	O-RING (920 D90)	
16.	117-226	-	EXTERNAL SNAP RING (.750")	SEE FOOTNOTE 2
	115-545	-	EXTERNAL SNAP RING (.75")	
17.	350-689	-	PLUNGER	SEE FOOTNOTE 2
	308-603	-	PLUNGER	SEE FOOTNOTE 3
	166-280	1	PLUNGER	
18.	155-748	1	O-RING (916 D90)	
19.	350-693	1	PUMP BARREL	
20.	301-0196	1	RETAINER CLIP	SEE FOOTNOTE 4
21.	105-525	1	ROLL PIN (3/16" X 1/4")	SEE FOOTNOTE 3
22.	178-467	1	ROD CAP	SEE FOOTNOTE 3

NOT SHOWN:

FOOTNOTES:

1. INSTALL WITH SMALLER BEVEL TOWARD INSIDE OF PUMP
2. 308-603 PLUNGER IS A DIRECT REPLACEMENT OF 350-689 PLUNGER, 117-226 RETAINER RING, AND AN ADDITIONAL 350-671 ROD GUIDE.
3. USE 166-280, 178-467 & 105-525 TO SUPERSEDE 308-603
4. RETAINER CLIP 301-0196 SUPERSEDES CLIP 105-653

NOTE:

APPLICATOR

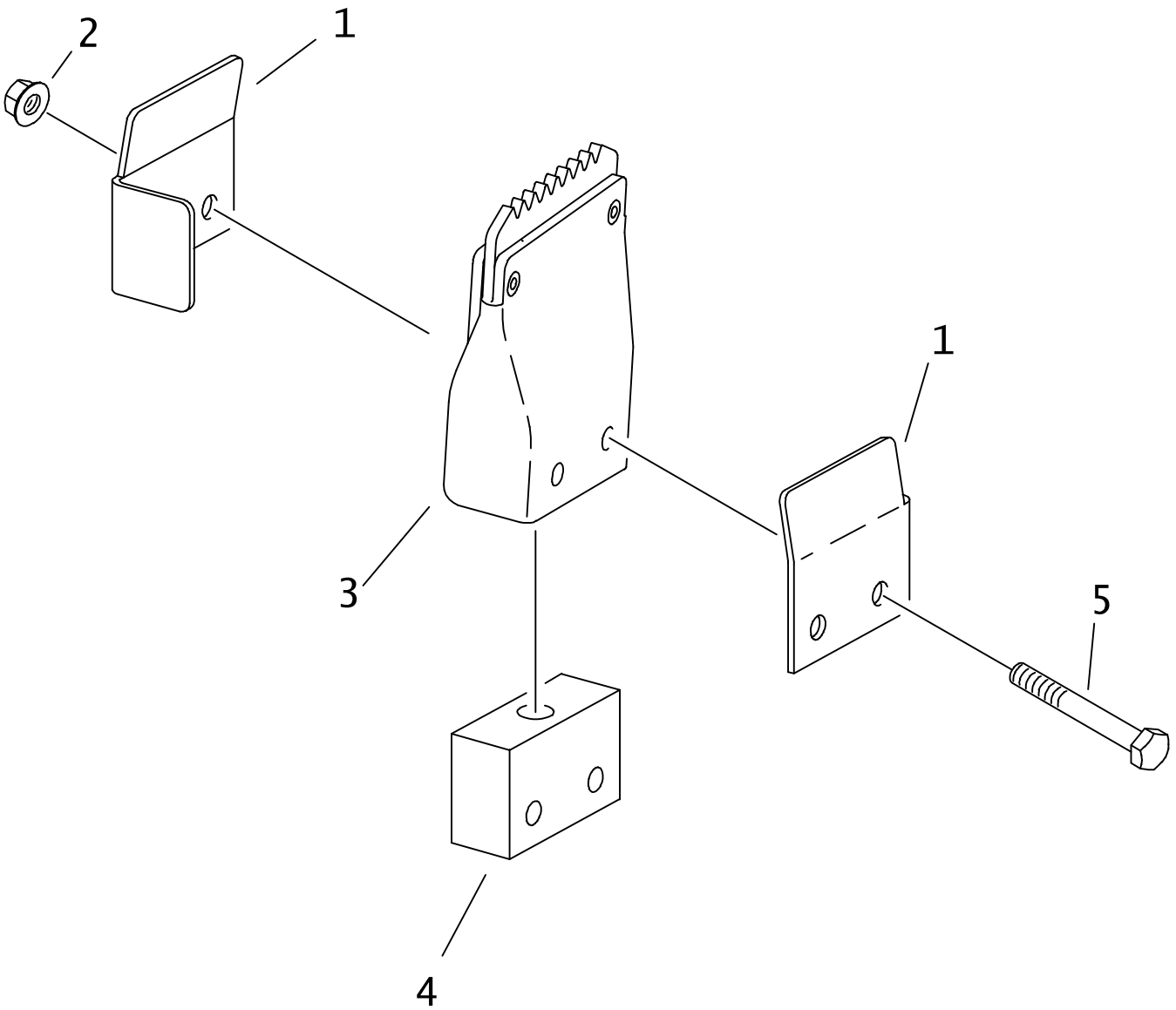

APPLICATOR

REF NO.	PART NUMBER	QTY	DESCRIPTION	REMARKS
1.	305-911	2	BRACKET, APPLICATOR	
2.	106-385	2	FLG LOCKNUT (M6-1.00)	
3.	306-423	1	WIPER PARTS ASS'Y	
	116-937	1	APPLICATOR	
	107-394	4	WASHER (.375", ALUMINUM)	
	107-395	2	RIVET (.156 X .500) SEMI-TUBUL	
4.	305-912	1	BASE, APPLICATOR	
5.	106-093	2	SCREW (M6-1.00 X 45MM)	

NOT SHOWN:

FOOTNOTES:

NOTE:

SELECTOR VALVE

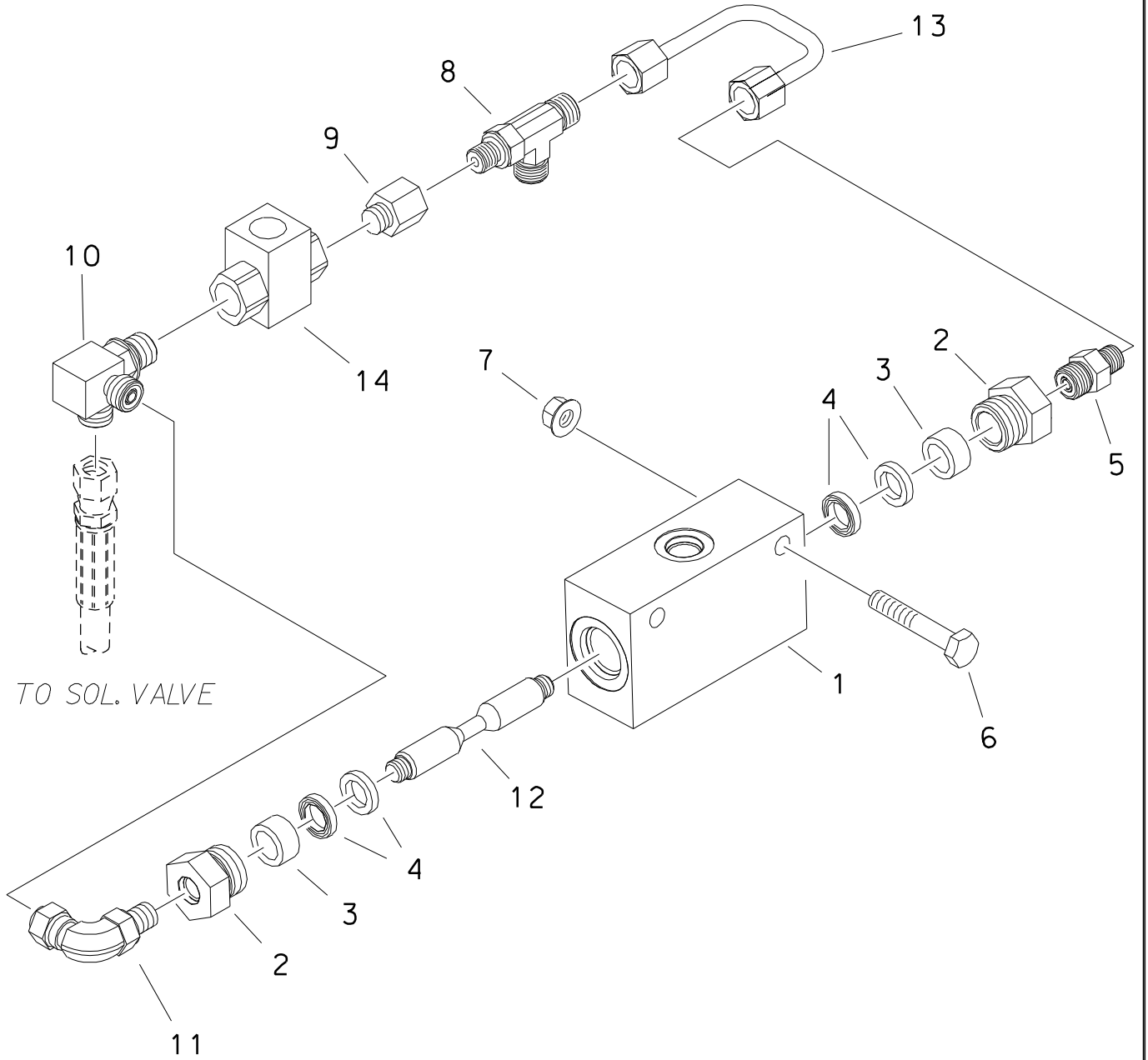

SELECTOR VALVE

REF NO.	PART NUMBER	QTY	DESCRIPTION	REMARKS
	101-085		GREASER VALVE KIT	INCL. REF. 1-4 & 12
1.	343-291	1	VALVE BODY	
2.	149-152	2	REDUCER (10S-04SF)	
3.	343-292	2	SPACER	
4.	116-880	4	SEAL (POLY PAK)	
5.	154-278	1	CONNECTOR (04S-040)	
6.	106-329	2	SCREW (M8-1.25 X 50MM)	
7.	106-386	2	FLG LOCKNUT (M8-1.25)	
8.	154-316	1	RUN TEE (04S-040-040)	
9.	155-254	1	REDUCER (06S-04SF)	
10.	154-230	1	BRANCH TEE (06S-040-040)	
11.	514-257	1	UNION (04S-040FX90)	
12.	350-690	1	VALVE SPOOL	
13.	149-519	1	HYD LINE	
14.	158-600	1	HYD SHUTTLE VALVE	

FOOTNOTES

NOTE:

REFER TO O-RING CHART (800-301) IN BACK OF THE BOOK FOR REPLACEMENT OF O-RINGS.

DRILL FRAME

PIVOT

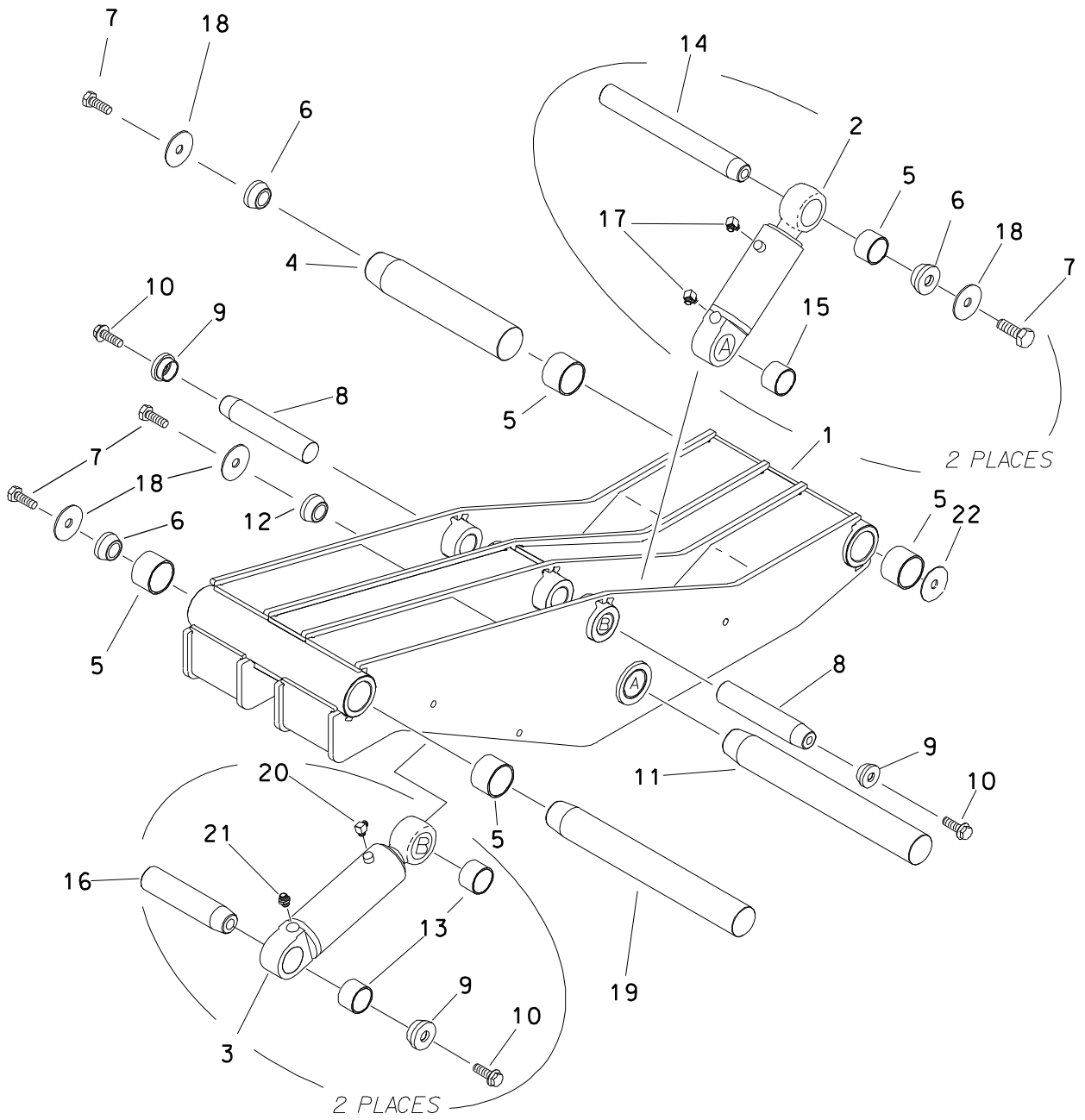

PIVOT

REF NO.	PART NUMBER	QTY	DESCRIPTION	REMARKS
1.	350-724	1	PIVOT	
2.	151-066	2	CYL (4" X 2" X 5")	
3.	151-070	2	CYL (3" X 1.75" X 8")	
4.	179-220	1	TAPERED PIN (50.8mm X 585mm)	
5.	125-754	6	COMPOSITION BUSHING (2")	
6.	184-064	4	TAPERED INSERT (2.00")	
7.	106-798	5	SCREW (M20-2.50 X 55MM, 10.9)	
8.	183-768	2	TAPERED PIN (44.4mm X 205mm)	
9.	181-975	4	TAPERED INSERT (1.750")	
10.	106-470	4	FLG SCREW (M16-2.00 X 40mm)	
11.	179-221	1	TAPERED PIN (57.1mm X 425mm)	
12.	184-031	1	TAPERED INSERT (2.250")	
13.	125-773	4	COMPOSITION BUSHING (1.75")	
14.	179-077	2	TAPERED PIN (50.8mm X 170mm)	
15.	125-781	2	COMPOSITION BUSHING (2.259")	
16.	183-882	2	TAPERED PIN (44.4mm X 228.6mm)	
17.	154-276	4	CONNECTOR (040-08S90)	
18.	106-399	5	WASHER (M20, HARDENED)	
19.	179-248	1	2.0" X 22.04" PIN	
20.	154-226	2	CONNECTOR (040-06S90)	
21.	154-220	2	CONNECTOR (040-06S)	
22.	110-168	4	MACHINERY BUSHING (2.00")	

FOOTNOTES

NOTE
REFER TO O-RING CHART (800-301) IN BACK OF THE BOOK FOR REPLACEMENT OF O-RINGS.

THRUST DRIVE

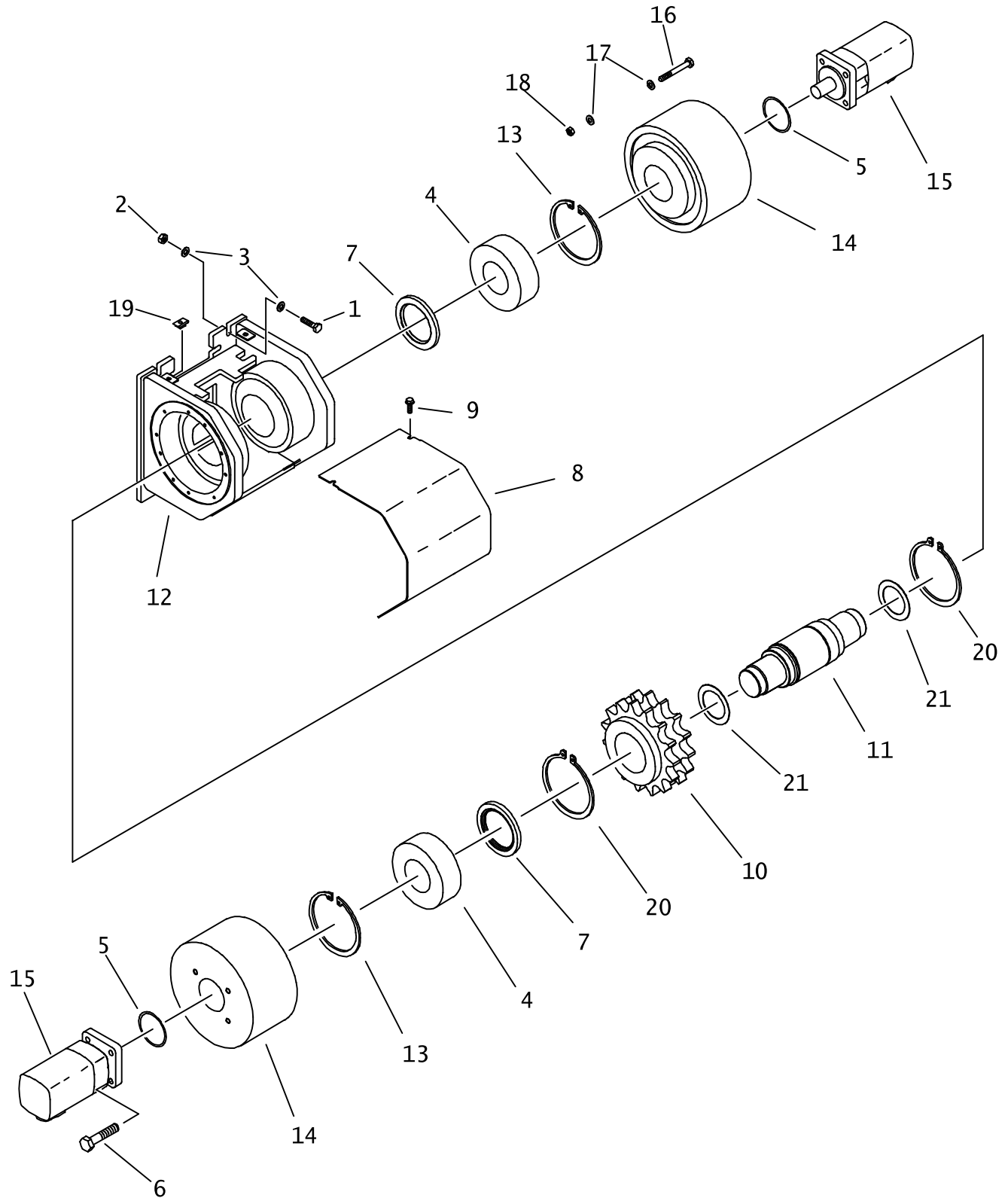

THRUST DRIVE

REF NO.	PART NUMBER	QTY	DESCRIPTION	REMARKS
1.	106-334	8	SCREW (M12-1.75 X 50mm)	
2.	106-685	8	LOCKNUT (M12-1.75, PRV TRQ, 10.9)	
3.	106-397	16	WASHER (M12, HARDENED)	
4.	125-314	2	ROLLER BEARING (2.952")	
5.	157-084	2	O-RING (159 D70)	
6.	105-066	8	BOLT (1/2-NC X 1-3/4")	
7.	155-883	2	INTERNAL SEAL (3.750")	
8.	350-726	1	THRUST DRIVE COVER	
9.	106-991	4	FLG LK SCREW (M8-1.25 X 20MM)	
10.	174-028	1	SPROCKET, THRUST DRIVE, SPLINE	
11.	167-318	1	THRUST DRIVE SHAFT	
12.	350-725	1	THRUST DRIVE HOUSING	
13.	118-031	2	INTERNAL SNAP RING (6.250")	
14.	166-151	2	GEARBOX PLANETARY	SEE FOOTNOTE 1
	501-861		PRIMARY CARRIER (8")	
	501-862		SECONDARY CARRIER (8")	
	501-863		COVER	
	501-864		RING GEAR, 8"	OBSOLETE
	501-865		SUN GEAR, 8"	
15.	158-026	2	HYDRAULIC MOTOR (15 CU/IN)	
	500-1552		SEAL REPAIR KIT	
	500-1553		SHAFT AND BEARING KIT	
	500-711		SEAL REPAIR KIT - REAR	
	500-758		SEAL REPAIR KIT - SHAFT	
16.	105-808	24	BOLT (3/8-NC X 7")	TORQUE TO 40 FT-LB
17.	106-390	48	WASHER (M10)	
18.	105-047	24	LOCKNUT (3/8-NC)	
19.	106-551	4	CLIP NUT (M8-1.25)	
20.	118-044	2	EXTERNAL SNAP RING (4.250")	
21.	126-127	AR	THRUST WASHER RACE (1.750")	

NOT SHOWN:

FOOTNOTES:

1. APPLY A 3/16" MIN BEAD OF LOCTITE SUPERFLEX HIGH TEMP RTV (OR EQUIVALENT) ON BOTH SIDES OF EACH PLANETARY.

NOTE:

CARRIAGE AT42M1 & AT42T2 ONLY

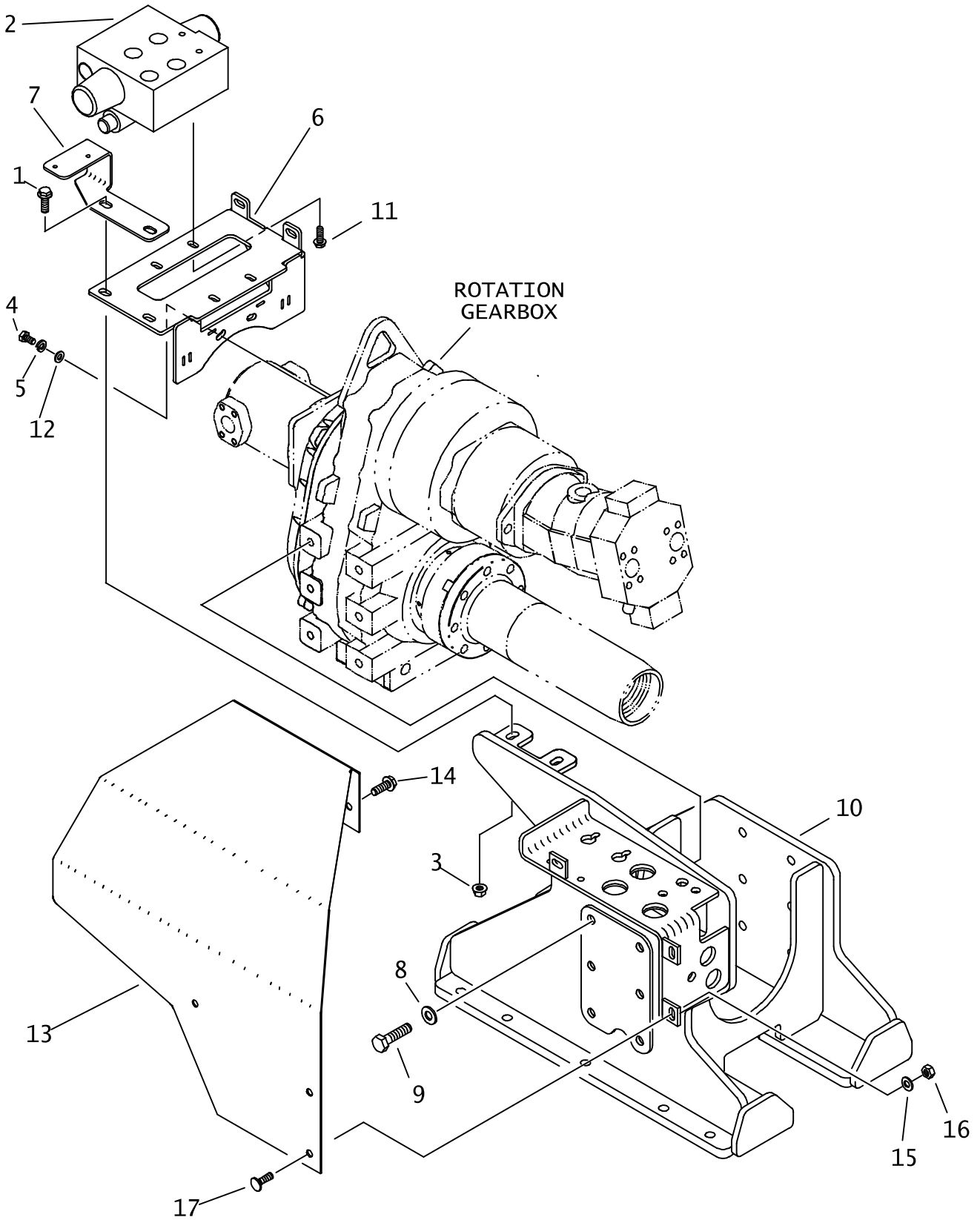

CARRIAGE AT42M1 & AT42T2 ONLY

REF NO.	PART NUMBER	QTY	DESCRIPTION	REMARKS
1.	107-003	2	FLG LK SCREW (M12-1.75 X 35MM)	
2.	153-773	1	HYDRAULIC VALVE	
3.	106-354	2	FLANGE NUT (M12-1.75)	
4.	105-245	2	SCREW (M10-1.50 X 25MM)	
5.	106-090	2	LOCK WASHER (M10)	
6.	316-958	1	VALVE MOUNT PLATE	
7.	314-580	1	BRACKET	
8.	106-398	12	WASHER (M16, HARDENED)	
9.	106-666	12	SCREW (M16-2.00 X 65MM, 10.9)	USE 277 LOCTITE; TORQUE TO 225 FT LBS
10.	313-958	-	CARRIAGE	
11.	105-826	4	FLG LOCK BOLT (3/8-NC X 1")	USE 242 LOCTITE, AT ONLY
12.	106-390	2	WASHER (M10)	
13.	318-731	1	CARRIAGE COVER	
14.	106-469	2	FLG SCREW (M12-1.75 X 30MM)	
15.	106-391	5	WASHER (M12)	
16.	106-685	5	LOCKNUT(M12-1.75,PRV TRQ,10.9)	
17.	107-683	3	CARRIAGE BOLT(M12-1.75 X 30MM)	

FOOTNOTES

NOTE:

H

808-079

CARRIAGE

JT42M1 & JT42T2 ONLY

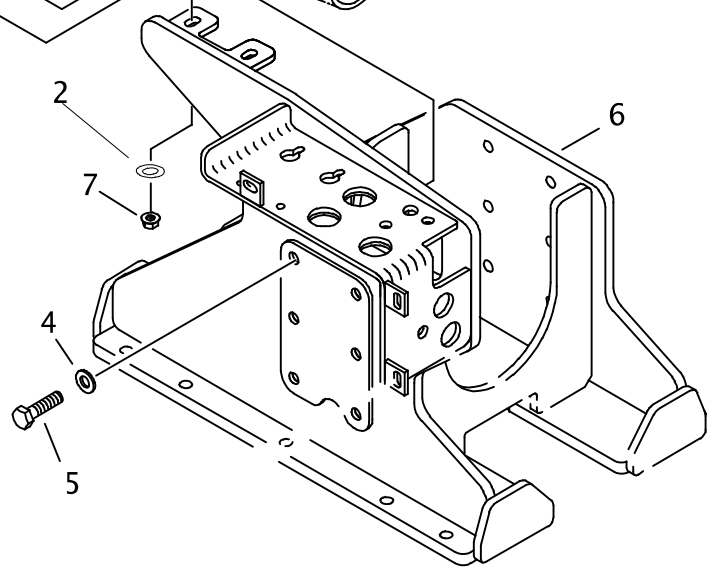
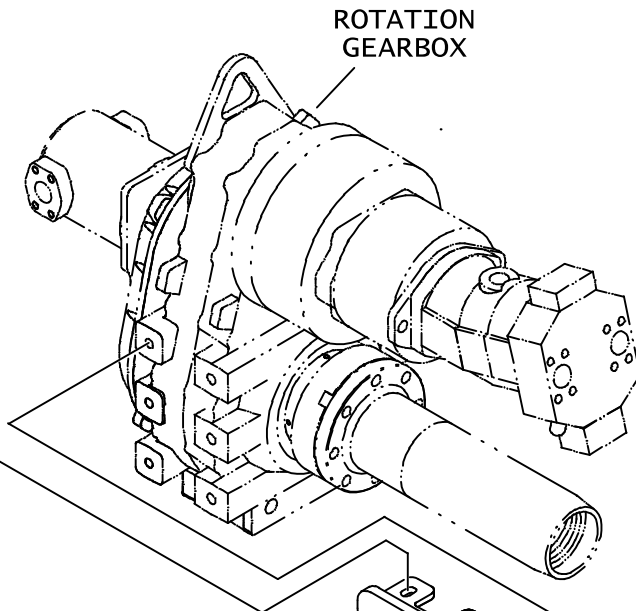
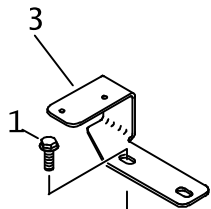

CARRIAGE

JT42M1 & JT42T2 ONLY

REF NO.	PART NUMBER	QTY	DESCRIPTION	REMARKS
1.	106-632	2	FLG LK SCR (M12-1.75X35MM,SER)	
2.	106-397	2	WASHER (M12, HARDENED)	
3.	314-580	1	BRACKET	
4.	106-398	12	WASHER (M16, HARDENED)	
5.	106-666	12	SCREW (M16-2.00 X 65MM, 10.9)	USE 277 LOCTITE; TORQUE TO 225 FT LBS
6.	313-958	-	CARRIAGE	
7.	106-685	2	LOCKNUT(M12-1.75,PRV TRQ,10.9)	

FOOTNOTES

NOTE:

B

809-534

CARRIAGE CHAIN

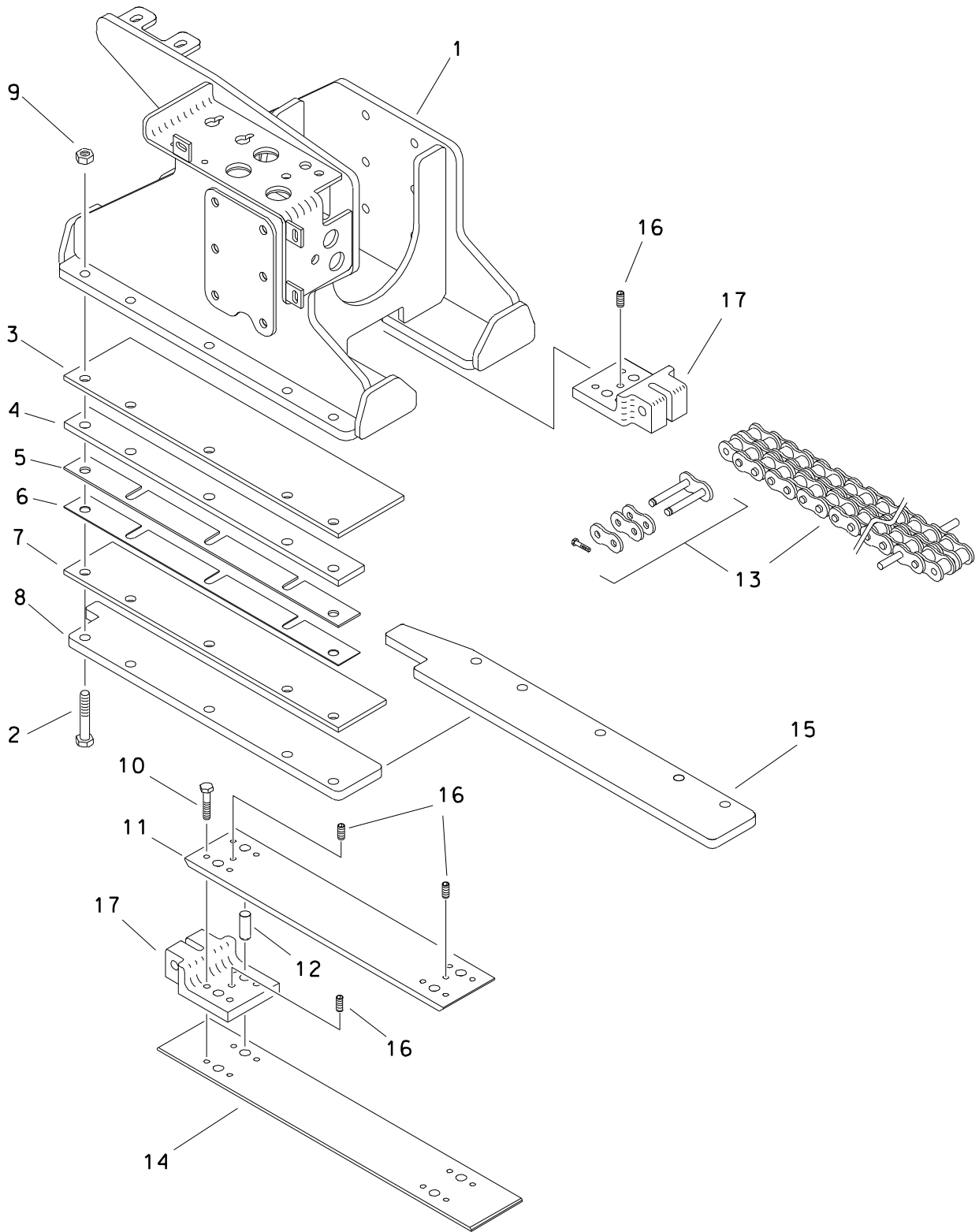

CARRIAGE CHAIN

REF NO.	PART NUMBER	QTY	DESCRIPTION	REMARKS
1.	313-958	1	CARRIAGE	
2.	107-144	10	SCREW (M16-2.00 X 100MM)	
3.	315-403	2	TOP SLIDE BAR	
4.	315-404	2	THICK SLIDE SPACER	
5.	315-405	2	THIN SLIDE SPACER	
6.	116-997	2	SLIDE SHIM	
7.	315-406	2	BOTTOM SLIDE BAR	
8.	178-963	1	SLIDE BAR	RIGHT SIDE
9.	106-545	10	LOCKNUT (M16-2.0,PRV TRQ,10.9)	
10.	107-748	8	SCREW (M12-1.75 X 50MM, 10.9)	LOCTITE 242
11.	314-488	1	SLIDE BAR	
12.	107-881	4	DOWEL PIN .750 X 2.250	
13.	129-011	1	ROLLER CHAIN ASS'Y #140-2 303P	
	130-622	-	EXTENDED PIN (#140-2, .707")	
	130-624	-	CONNECTOR LINK (#140-2, .707")	
	129-020	1	ROLLER CHAIN #140-2 303P	SEE FOOTNOTE 1.
	179-601	-	EXTD PIN LINK #140-2, .701"	
	129-023	-	CONNECTOR LINK (#140-2, .701")	
14.	313-918	1	SLIDE BAR	
15.	318-976	1	SLIDE BAR	LEFT SIDE
16.	107-303	4	SET SCREW (M12-1.75 X 20MM)	
17.	314-484	1	CHAIN ANCHOR (#140-2, .707")	

FOOTNOTES

1. ROLLER CHAIN ASSY (129-020) COMES WITH 2 CONNECTOR LINKS, AND 2 EXTENDED PINS.

THRUST IDLER

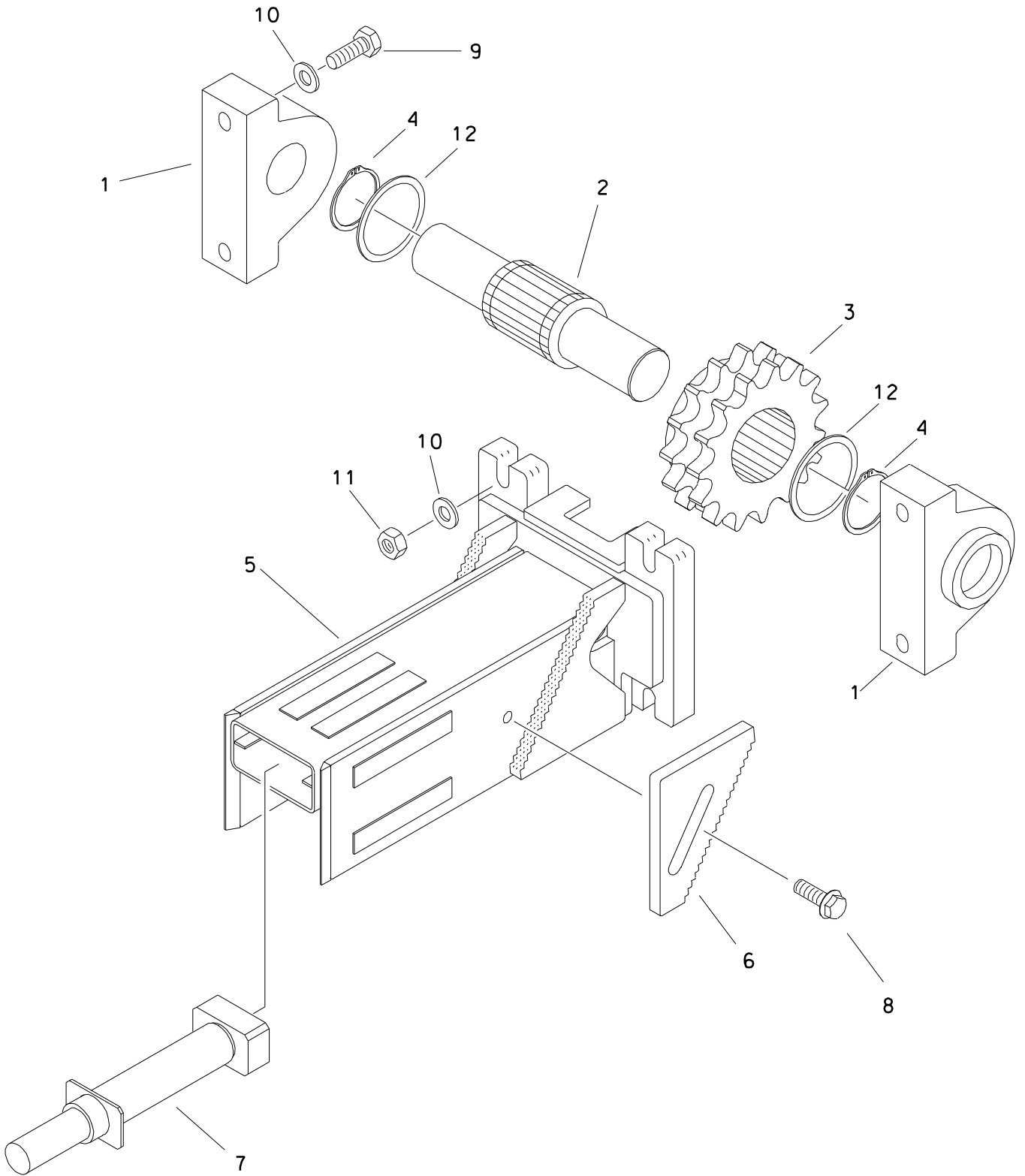

THRUST IDLER

REF NO.	PART NUMBER	QTY	DESCRIPTION	REMARKS
1.	125-523	2	PILLOW BLOCK BEARING (2.930")	
	125-558	-	ADAPTER SLEEVE KIT (125-523)	
2.	166-473	1	IDLER SHAFT	BEGINS WITH SN 2W0295; SEE FOOTNOTE 2
	167-319	-	IDLER SHAFT	
	101-133	1	THRUST IDLER KIT	INCL. REF. NO.'S 2 - (166-473), 4 - (115-453) & REF. 12
3.	174-028	1	SPROCKET, THRUST DRIVE, SPLINE	SAME AS THRUST DRIVE
4.	118-044	2	EXTERNAL SNAP RING (4.250")	REQUIRED WITH SHAFT 167-319
	115-453	2	EXTERNAL SNAP RING (4")	BEGINS WITH SN 2W0295; SEE FOOTNOTE 2
5.	308-775	1	THRUST IDLER HOUSING	
6.	308-767	2	ADJUSTMENT PLATE	KEEP BOTH SIDES ON SAME NOTCH WHEN ADJUSTING
7.	151-165	1	GREASE CYLINDER	SEE FOOTNOTE 1
8.	106-470	2	FLG SCREW (M16-2.00 X 40mm)	
9.	106-633	4	BOLT (M20-2.50 X 130mm)	
10.	105-460	8	WASHER (13/16")	
11.	106-665	4	LOCKNUT (M20-2.50, 10.9)	
12.	179-489	2	INPUT SHIM 4.002 X 4.750 X .135	BEGINS WITH SN 2W0295; SEE FOOTNOTE 2

FOOTNOTES

1. WHEN ADJUSTING, RELEASE PRESSURE AFTER POSITIONING ADJUSTMENT PLATES
2. WHEN REPLACING IDLER SHAFT (167-319),
ORDER 101-133 WHICH INCLUDES:

115-453	2	EXTERNAL SNAP RING
166-473	1	IDLER SHAFT
179-489	2	INPUT SHIM 4.002 X 4.750 X .135

ROTATION GEARBOX
JT4020 ALL TERRAIN ONLY
ENDS WITH S/N: CMWA40T3P70000017

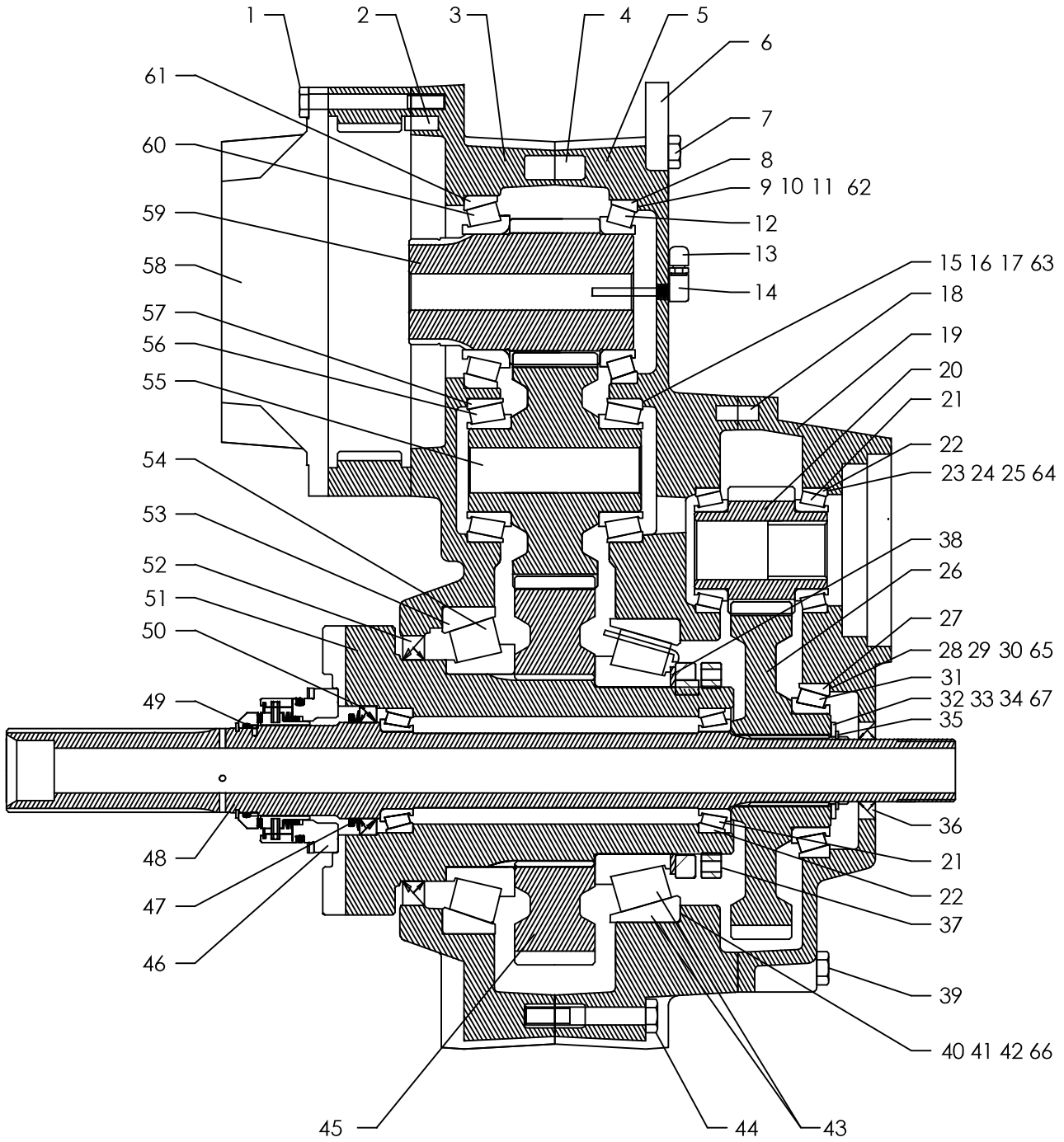

ROTATION GEARBOX
JT4020 ALL TERRAIN ONLY
ENDS WITH S/N: CMWA40T3P70000017

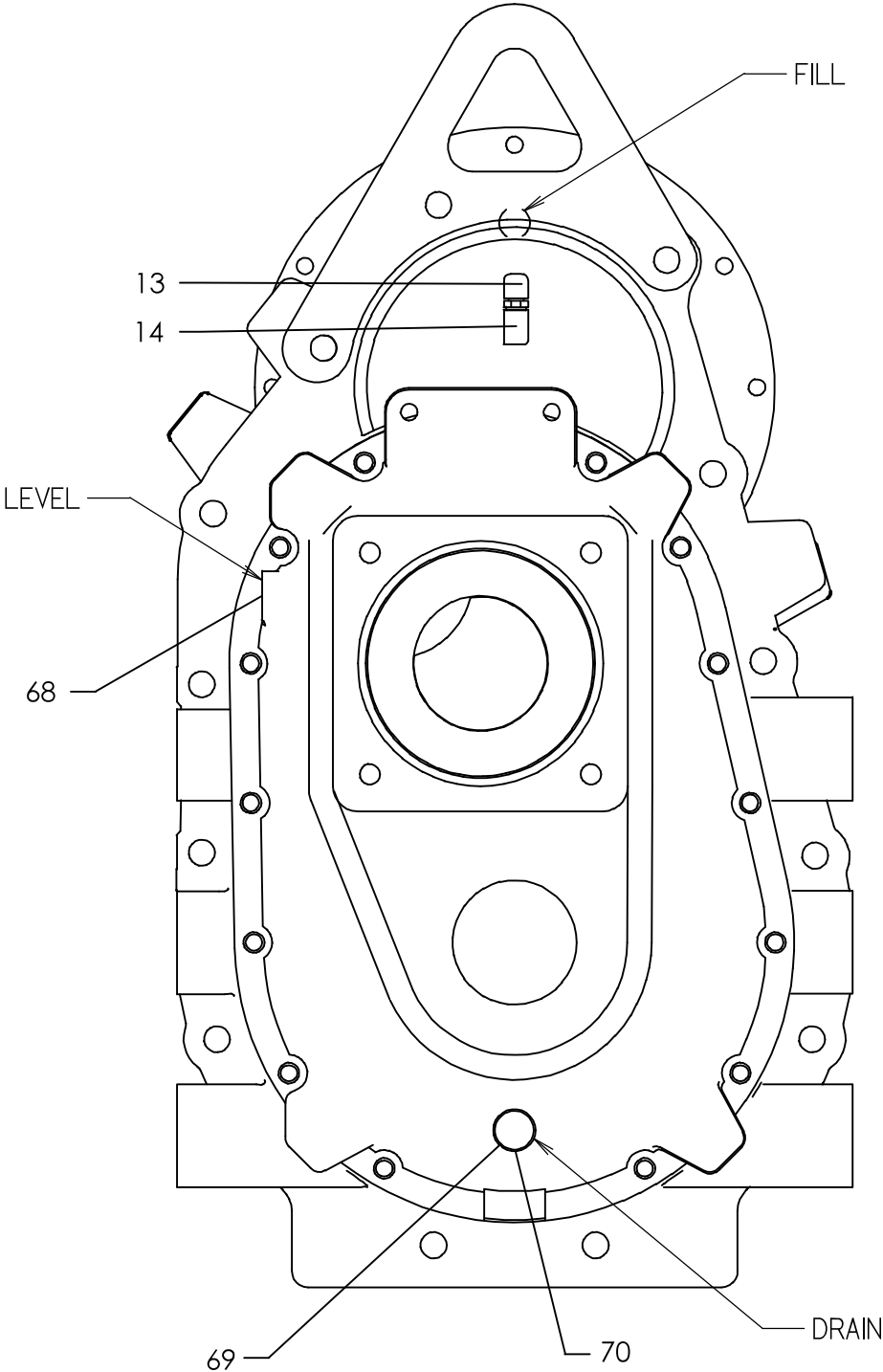

ROTATION GEARBOX
JT4020 ALL TERRAIN ONLY
ENDS WITH S/N: CMWA40T3P70000017

REF NO.	PART NUMBER	QTY	DESCRIPTION	REMARKS
	166-468	-	{AT} REBUILT GEARBOX	
	166-488	-	{AT} ROTATION DRIVE GEARBOX	NEW GEARBX, INCL REF. #'S 1-45,47,48,50-71.
1.	105-179	12	BOLT (3/8-NC X 3-1/2")	TORQUE TO 40 FT LBS. (54 N - M)
2.	105-534	3	DOWEL PIN (.375" X .875")	
3.	314-590	1	COVER CASTING (MACHINED)	
4.	500-818	2	DOWEL PIN (16MM X 40MM)	
5.	314-356	1	COVER CASTING (MACHINED)	
6.	313-947	-	LIFT BRACKET	
7.	106-336	-	SCREW (M12-1.75 X 90MM)	
8.	125-359	1	TAPERED RACE (4.781")	
9.	165-868	3	SHIM (.076MM)	
10.	165-869	3	SHIM (.051MM)	
11.	165-870	3	SHIM (.178MM)	
12.	125-360	1	TAPERED BEARING (3.000")	
13.	159-003	1	AIR VENT (02N)	
14.	514-123	1	PICKUP TUBE (02N-02NF90-2")	
15.	165-842	3	SHIM (.051MM)	
16.	165-843	3	SHIM (.076MM)	
17.	165-844	3	SHIM (.178MM)	
18.	106-866	2	DOWEL PIN (M10 X 30MM)	
19.	314-355	1	MOTOR COVER	
20.	166-402	1	INPUT PINION	
21.	126-100	4	TAPERED BEARING (2")	
22.	126-099	4	TAPERED RACE (3.25")	
23.	165-800	2	SHIM (.002")	
24.	165-801	2	SHIM (.003")	
25.	165-802	2	SHIM (.007")	
26.	166-403	1	GEAR	
27.	126-012	1	TAPERED RACE (4.527")	
28.	117-535	2	SHIM	
29.	117-536	2	SHIM	
30.	117-537	2	SHIM	
31.	126-013	1	TAPERED BEARING (2.952")	
32.	107-705	1	BEARING RACE (THRUST)	
33.	126-127	1	THRUST WASHER RACE (1.750")	
34.	117-534	1	SHIM	
35.	115-456	1	EXTERNAL SNAP RING (1.750")	

NOT SHOWN:

FOOTNOTES:

NOTE:

ROTATION GEARBOX
JT4020 ALL TERRAIN ONLY
ENDS WITH S/N: CMWA40T3P70000017

REF NO.	PART NUMBER	QTY	DESCRIPTION	REMARKS
36.	153-616	1	INTERNAL SEAL (2.535")	
37.	107-706	1	NUT, SPANNER	
	190-1386	1	GEARBOX NUT	
	255-1006	-	MOLLY PASTE (SINGLE APPLICATION)	
38.	105-1313	1	HARDEND WASHER	
39.	106-755	14	SCREW (M10-1.50 X 30MM, SOC)	
40.	165-810	3	SHIM (.002")	
41.	165-811	3	SHIM (.003")	
42.	165-812	3	SHIM (.007")	
43.	125-1009	1	TAPERED BRNG/RACE (110MM)	SEE FOOTNOTE 2
44.	106-117	10	SCREW (M12-1.75 X 80MM)	
45.	168-036	1	OUTPUT GEAR	
46.	191-278	1	SEAL KIT	INCLUDES REF. 49
	157-285	-	O-RING (238 D75 VITON)	
47.	153-614	1	SEAL, V-RING	
48.	166-387	1	SHAFT	
49.	107-803	1	PIN .125 X .25	
50.	155-801	1	INTERNAL SEAL (2.500")	
51.	166-388	1	SHAFT	
52.	153-615	1	INTERNAL SEAL (5.750" ID)	
53.	125-500	1	BEARING CUP	
54.	125-525	1	CONE	
55.	168-035	1	IDLER GEAR	
56.	126-170	2	TAPERED BEARING (2.250")	
57.	126-171	2	TAPERED RACE (3.740")	
58.	166-152	1	ROTATION GEARBOX PLANETARY	SEE FOOTNOTE 1
59.	168-034	1	INPUT PINION	
60.	125-308	1	TAPERED BEARING (3.000")	
61.	125-309	1	TAPERED RACE (5.000")	
62.	107-578	2	SHIM (.020")	
63.	107-577	2	SHIM (.020")	
64.	107-575	2	SHIM (.020")	
65.	179-309	2	SHIM .020"	
66.	179-310	2	SHIM .020"	
67.	110-054	1	MACHINE BUSHING (1-3/4", 14GA)	
68.	115-025	1	PLUG (08N, SQ FM, MAG)	
69.	115-161	1	NIPPLE (08N, 3-1/2")	
70.	514-106	-	CAP (08NF)	

NOT SHOWN:

FOOTNOTES:

1. APPLY LOCTITE SUPERFLEX RED HIGH TEMP RTV OR EQUIVALENT - 3/16 DIA. MIN. BEAD.
2. 126-172 SUPERSEDED BY 125-1009. TIMKEN® 32222M WILL NOT WORK IN THIS APPLICATION.

NOTE:

ROTATION GEARBOX
JT4020 ALL TERRAIN ONLY
BEGINS WITH S/N: CMWA40T3K70000018

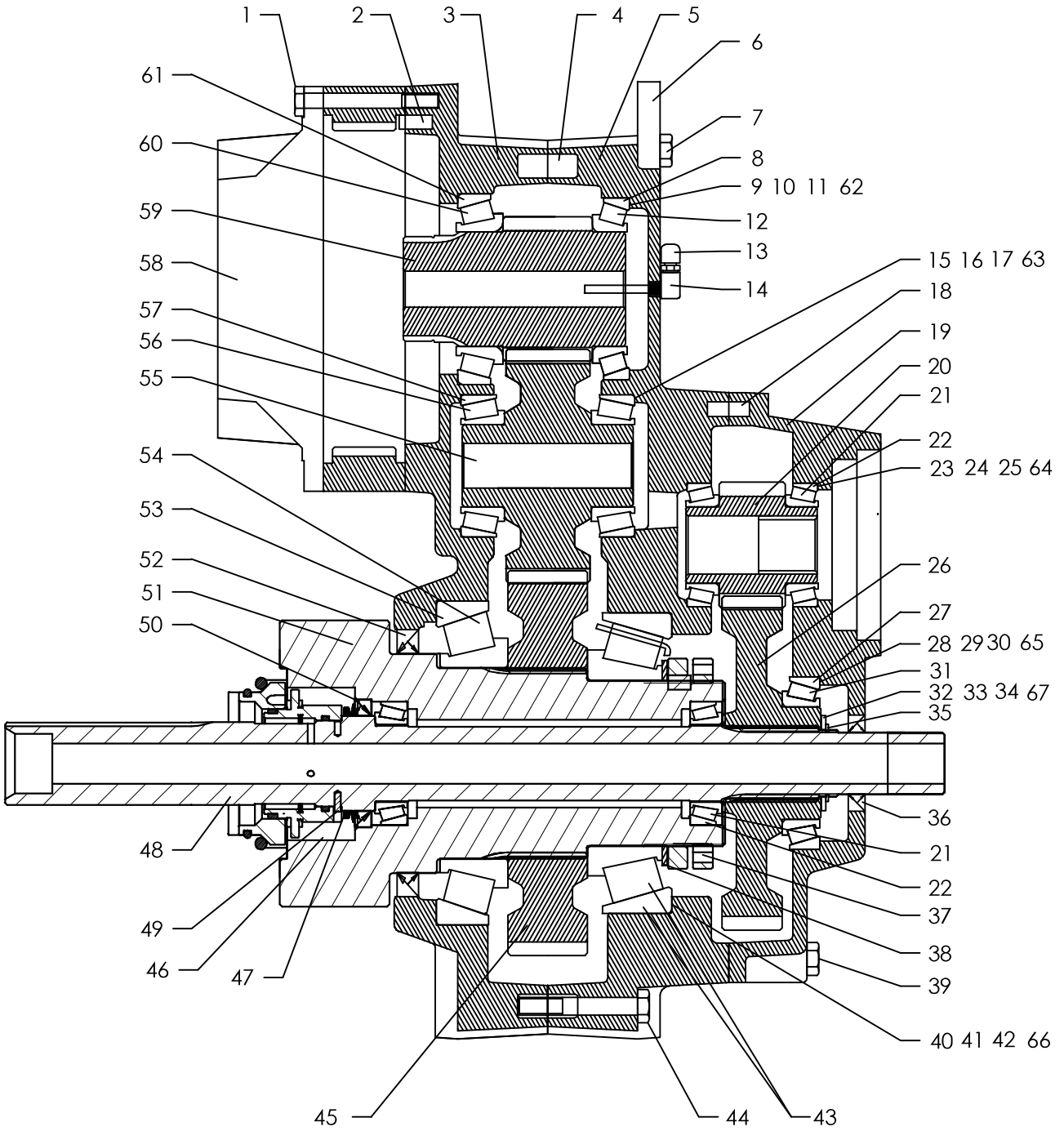

ROTATION GEARBOX
JT4020 ALL TERRAIN ONLY
BEGINS WITH S/N: CMWA40T3K70000018

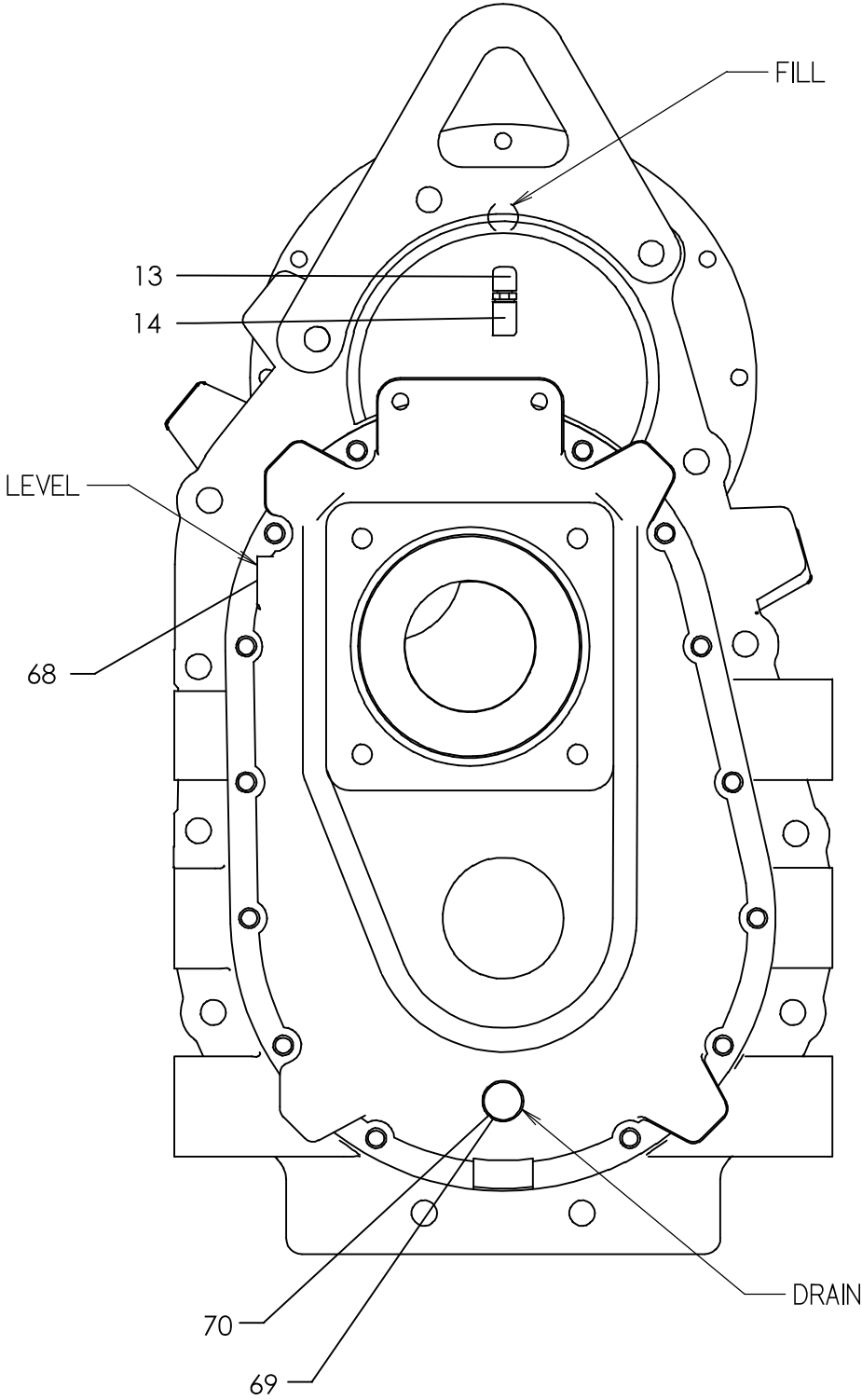

ROTATION GEARBOX
JT4020 ALL TERRAIN ONLY
BEGINS WITH S/N: CMWA40T3K70000018

REF NO.	PART NUMBER	QTY	DESCRIPTION	REMARKS
	166-468	-	{AT} REBUILT GEARBOX	
	166-488	-	{AT} ROTATION DRIVE GEARBOX	NEW GEARBX, INCL REF. #S 1-45,47,48,50-71.
1.	105-179	12	BOLT (3/8-NC X 3-1/2")	TORQUE TO 40 FT LBS. (54 N - M)
2.	105-534	3	DOWEL PIN (.375" X .875")	
3.	314-590	1	COVER CASTING (MACHINED)	
4.	500-818	2	DOWEL PIN (16MM X 40MM)	
5.	314-356	1	COVER CASTING (MACHINED)	
6.	313-947	-	LIFT BRACKET	
7.	106-336	-	SCREW (M12-1.75 X 90MM)	
8.	125-359	1	TAPERED RACE (4.781")	
9.	165-868	3	SHIM (.076MM)	
10.	165-869	3	SHIM (.051MM)	
11.	165-870	3	SHIM (.178MM)	
12.	125-360	1	TAPERED BEARING (3.000")	
13.	159-003	1	AIR VENT (02N)	
14.	514-123	1	PICKUP TUBE (02N-02NF90-2")	
15.	165-842	3	SHIM (.051MM)	
16.	165-843	3	SHIM (.076MM)	
17.	165-844	3	SHIM (.178MM)	
18.	106-866	2	DOWEL PIN (M10 X 30MM)	
19.	314-355	1	MOTOR COVER	
20.	166-402	1	INPUT PINION	
21.	126-100	4	TAPERED BEARING (2")	
22.	126-099	4	TAPERED RACE (3.25")	
23.	165-800	2	SHIM (.002")	
24.	165-801	2	SHIM (.003")	
25.	165-802	2	SHIM (.007")	
26.	166-403	1	GEAR	
27.	126-012	1	TAPERED RACE (4.527")	
28.	117-535	2	SHIM	
29.	117-536	2	SHIM	
30.	117-537	2	SHIM	
31.	126-013	1	TAPERED BEARING (2.952")	
32.	107-705	1	BEARING RACE (THRUST)	
33.	126-127	1	THRUST WASHER RACE (1.750")	
34.	117-534	1	SHIM	
35.	115-456	1	EXTERNAL SNAP RING (1.750")	

NOT SHOWN:

FOOTNOTES:

NOTE:

ROTATION GEARBOX
JT4020 ALL TERRAIN ONLY
BEGINS WITH S/N: CMWA40T3K70000018

REF NO.	PART NUMBER	QTY	DESCRIPTION	REMARKS
36.	153-616	1	INTERNAL SEAL (2.535")	
37.	107-706	1	NUT, SPANNER	OBSOLETE
	190-1386	1	GEARBOX NUT	
	255-1006	-	MOLLY PASTE (SINGLE APPLICATION)	
38.	105-1313	1	HARDENED WASHER	
39.	106-755	14	SCREW (M10-1.50 X 30MM, SOC)	
40.	165-810	3	SHIM (.002")	
41.	165-811	3	SHIM (.003")	
42.	165-812	3	SHIM (.007")	
43.	125-1009	1	TAPERED BRNG/RACE (110MM)	SEE FOOTNOTE 2
44.	106-117	10	SCREW (M12-1.75 X 80MM)	
45.	168-036	1	OUTPUT GEAR	
46.	190-1163	1	SEAL KIT	INCLUDES REF. 49
47.	153-614	1	SEAL, V-RING	
48.	166-491	1	SHAFT	
49.	105-1539	1	PIN, GROOVED (5/32" X 1/2")	
50.	155-801	1	INTERNAL SEAL (2.500")	
51.	166-492	1	SHAFT	
52.	153-615	1	INTERNAL SEAL (5.750" ID)	
53.	125-500	1	BEARING CUP	
54.	125-525	1	CONE	
55.	168-035	1	IDLER GEAR	
56.	126-170	2	TAPERED BEARING (2.250")	
57.	126-171	2	TAPERED RACE (3.740")	
58.	166-152	1	ROTATION GEARBOX PLANETARY	SEE FOOTNOTE 1
59.	168-034	1	INPUT PINION	
60.	125-308	1	TAPERED BEARING (3.000")	
61.	125-309	1	TAPERED RACE (5.000")	
62.	107-578	2	SHIM (.020")	
63.	107-577	2	SHIM (.020")	
64.	107-575	2	SHIM (.020")	
65.	179-309	2	SHIM .020"	
66.	179-310	2	SHIM .020"	
67.	110-054	1	MACHINE BUSHING (1-3/4", 14GA)	
68.	115-025	1	PLUG (08N, SQ FM, MAG)	
69.	115-161	1	NIPPLE (08N, 3-1/2")	
70.	514-106	-	CAP (08NF)	

NOT SHOWN:

FOOTNOTES:

1. APPLY LOCTITE SUPERFLEX RED HIGH TEMP RTV OR EQUIVALENT - 3/16 DIA. MIN. BEAD.
2. 126-172 SUPERSEDED BY 125-1009. TIMKEN® 32222M WILL NOT WORK IN THIS APPLICATION.

NOTE:

ROTATION GEARBOX JT4020 MACH 1 ONLY

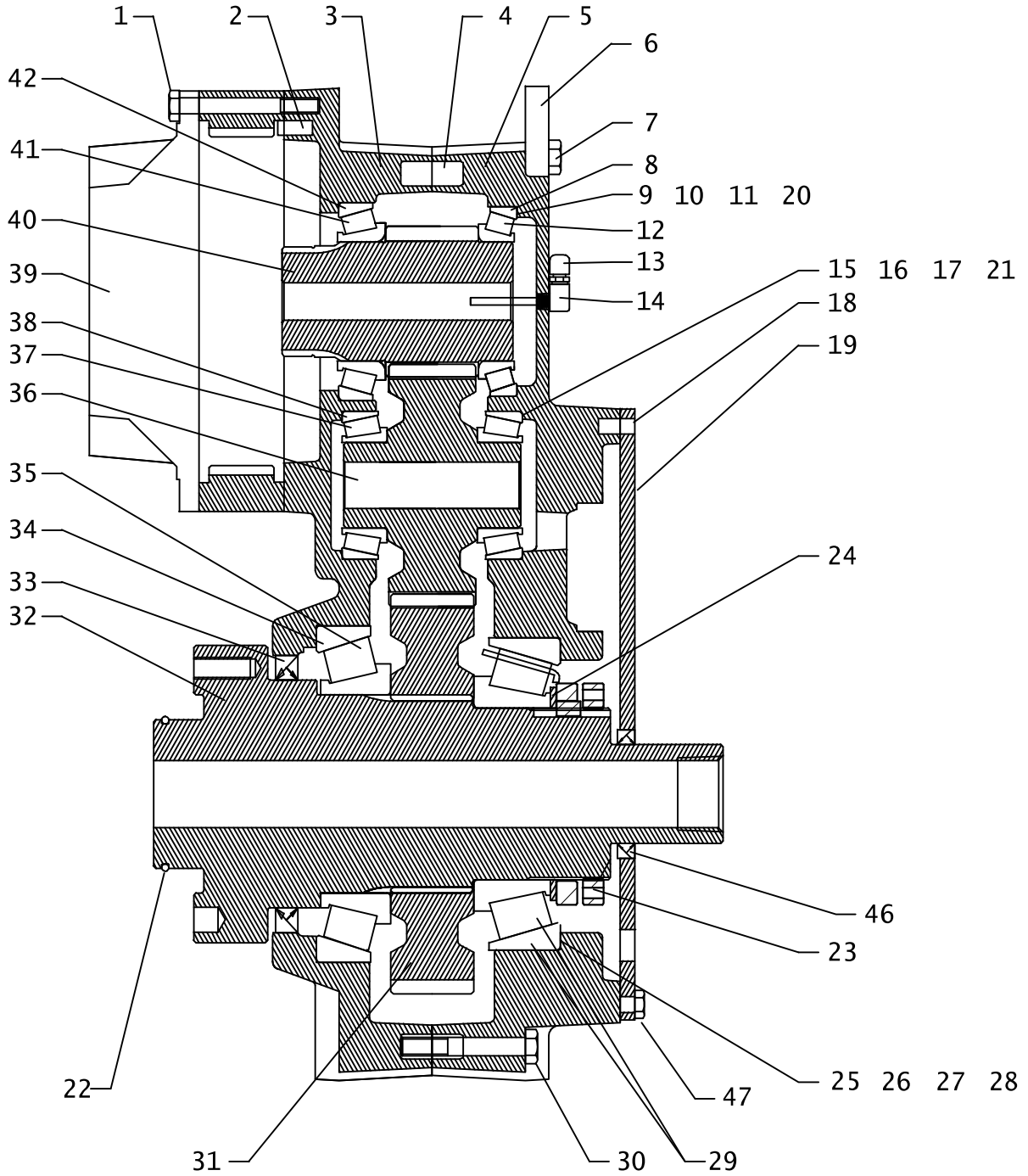

ROTATION GEARBOX

JT4020 MACH 1 ONLY

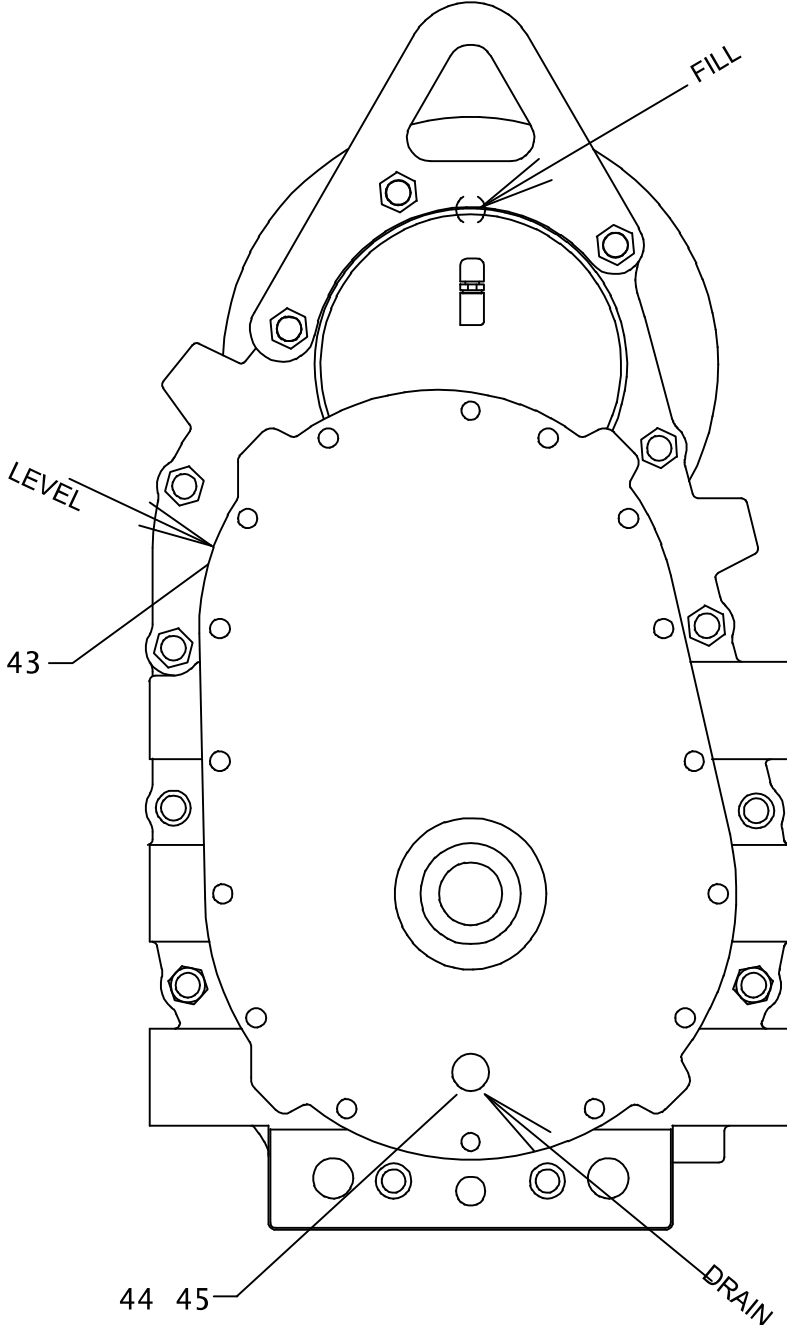

ROTATION GEARBOX

JT4020 MACH 1 ONLY

REF NO.	PART NUMBER	QTY	DESCRIPTION	REMARKS
	166-487	-	{JT} REBUILT ROTATION GEARBOX	
	166-489	-	{JT} ROTATION DRIVE GEARBOX	
1.	105-179	12	BOLT (3/8-NC X 3-1/2")	INCLUDES REF. #'S 1 - 48. TORQUE TO 40 FT LBS.
2.	105-534	3	DOWEL PIN (.375" X .875")	
3.	314-590	1	COVER CASTING (MACHINED)	
4.	500-818	2	DOWEL PIN (16MM X 40MM)	
5.	314-356	1	COVER CASTING (MACHINED)	
6.	313-947	-	LIFT BRACKET	
7.	106-336	-	SCREW (M12-1.75 X 90MM)	
8.	125-359	1	TAPERED RACE (4.781")	
9.	165-868	3	SHIM (.076MM)	
10.	165-869	3	SHIM (.051MM)	
11.	165-870	3	SHIM (.178MM)	
12.	125-360	1	TAPERED BEARING (3.000")	
13.	159-003	1	AIR VENT (02N)	
14.	514-123	1	PICKUP TUBE (02N-02NF90-2")	
15.	165-842	3	SHIM (.051MM)	
16.	165-843	3	SHIM (.076MM)	
17.	165-844	3	SHIM (.178MM)	
18.	106-866	2	DOWEL PIN (M10 X 30MM)	
19.	318-398	1	COVER	
20.	107-578	2	SHIM (.020")	
21.	107-577	2	SHIM (.020")	
22.	157-285	1	O-RING (238 D75 VITON)	
23.	<u>107-706</u>	1	NUT, SPANNER	
	190-1386	1	GEARBOX NUT	
	255-1006	-	MOLLY PASTE (SINGLE APPLICATION)	
24.	105-1313	1	HARDEND WASHER	
25.	165-810	3	SHIM (.002")	
26.	165-811	3	SHIM (.003")	
27.	165-812	3	SHIM (.007")	
28.	179-310	2	SHIM .020"	
29.	125-1009	1	TAPERED BRNG/RACE (110 mm)	SEE FOOTNOTE 2
30.	106-117	10	SCREW (M12-1.75 X 80MM)	
31.	168-036	1	OUTPUT GEAR	
32.	166-389	1	SHAFT	
33.	153-615	1	INTERNAL SEAL (5.750" ID)	
34.	125-500	1	BEARING CUP	

NOT SHOWN:

FOOTNOTES:

NOTE:

ROTATION GEARBOX

JT4020 MACH 1 ONLY

REF NO.	PART NUMBER	QTY	DESCRIPTION	REMARKS
35.	125-525	1	CONE	
36.	168-035	1	IDLER GEAR	
37.	126-170	2	TAPERED BEARING (2.250")	
38.	126-171	2	TAPERED RACE (3.740")	
39.	166-152	1	ROTATION GEARBOX PLANETARY	SEE FOOTNOTE 1
40.	168-034	1	INPUT PINION	
41.	125-308	1	TAPERED BEARING (3.000")	
42.	125-309	1	TAPERED RACE (5.000")	
43.	115-025	1	PLUG (08N, SQ FM, MAG)	
44.	115-161	1	NIPPLE (08N, 3-1/2")	
45.	514-106	-	CAP (08NF)	
46.	153-638	1	INTERNAL SEAL	
47.	106-755	14	SCREW (M10-1.50 X 30MM, SOC)	

NOT SHOWN:

FOOTNOTES:

1. APPLY LOCTITE SUPERFLEX RED HIGH TEMP RTV OR EQUIVALENT - 3/16 DIA. MIN. BEAD.
2. I26-I72 SUPERSEDED BY I25-I009. TIMKEN® 32222M WILL NOT WORK IN THIS APPLICATION.

NOTE:

ROTATION GEARBOX JT42M1 & JT42T2 ONLY

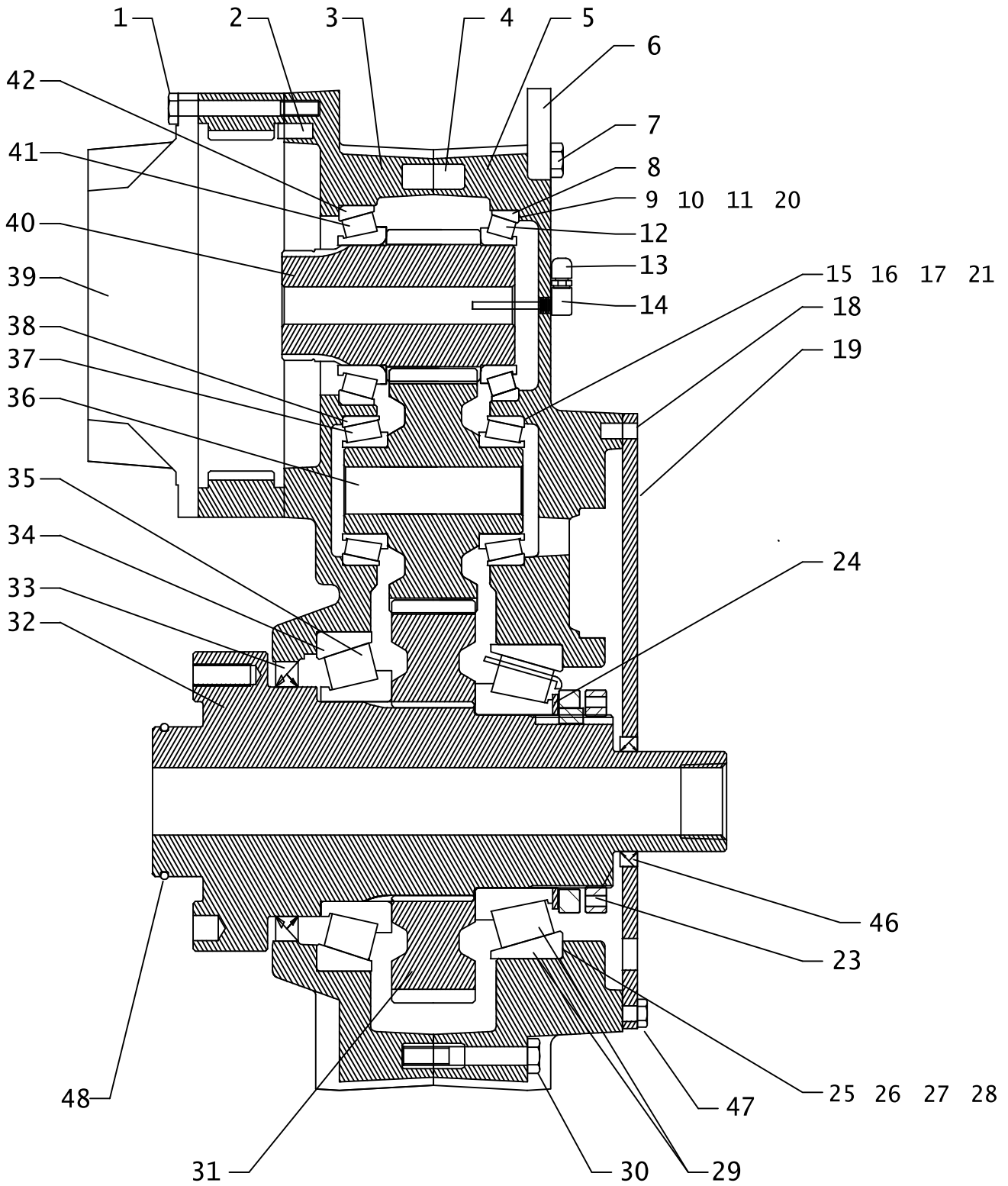

ROTATION GEARBOX
JT42M1 & JT42T2 ONLY

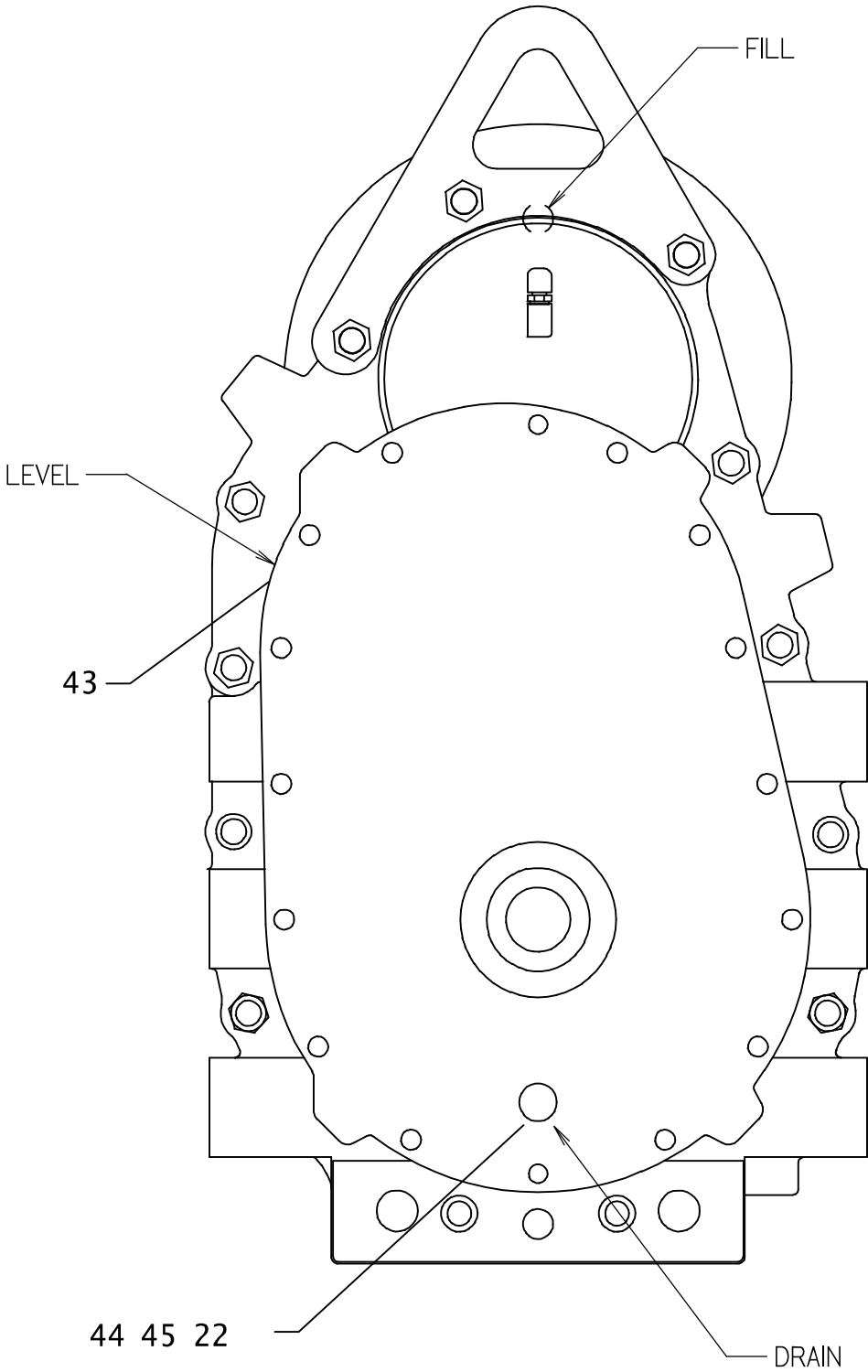

ROTATION GEARBOX JT42M1 & JT42T2 ONLY

REF NO.	PART NUMBER	QTY	DESCRIPTION	REMARKS
	166-487	-	{JT} REBUILT ROTATION GEARBOX	
	166-489	-	{JT} ROTATION DRIVE GEARBOX	
1.	105-179	12	BOLT (3/8-NC X 3-1/2")	INCLUDES REF. #'S 1 - 49.
2.	105-534	3	DOWEL PIN (.375" X .875")	TORQUE TO 40 FT LBS.
3.	314-590	1	COVER CASTING (MACHINED)	
4.	500-818	2	DOWEL PIN (16MM X 40MM)	
5.	314-356	1	COVER CASTING (MACHINED)	
6.	313-947	-	LIFT BRACKET	
7.	106-336	-	SCREW (M12-1.75 X 90MM)	
8.	125-359	1	TAPERED RACE (4.781")	
9.	165-868	3	SHIM (.076MM)	
10.	165-869	3	SHIM (.051MM)	
11.	165-870	3	SHIM (.178MM)	
12.	125-360	1	TAPERED BEARING (3.000")	
13.	159-003	1	AIR VENT (02N)	
14.	514-123	1	PICKUP TUBE (02N-02NF90-2")	
15.	165-842	3	SHIM (.051MM)	
16.	165-843	3	SHIM (.076MM)	
17.	165-844	3	SHIM (.178MM)	
18.	106-866	2	DOWEL PIN (M10 X 30MM)	
19.	318-398	1	COVER	
20.	107-578	2	SHIM (.020")	
21.	107-577	2	SHIM (.020")	
22.	115-112	1	PLUG (08N, SQ)	
23.	<u>107-706</u>	1	NUT, SPANNER	
	190-1386	1	GEARBOX NUT	
	255-1006	-	MOLLY PASTE (SINGLE APPLICATION)	
24.	105-1313	1	HARDEND WASHER	
25.	165-810	3	SHIM (.002")	
26.	165-811	3	SHIM (.003")	
27.	165-812	3	SHIM (.007")	
28.	179-310	2	SHIM .020"	SEE FOOTNOTE 3
29.	125-1009	1	TAPERED BRNG/RACE (110MM)	
30.	106-117	10	SCREW (M12-1.75 X 80MM)	
31.	168-036	1	OUTPUT GEAR	
32.	166-389	1	SHAFT	
33.	153-615	1	INTERNAL SEAL (5.750" ID)	
34.	125-500	1	BEARING CUP	
35.	125-525	1	CONE	

NOT SHOWN:

FOOTNOTES:

NOTE:

ROTATION GEARBOX JT42M1 & JT42T2 ONLY

REF NO.	PART NUMBER	QTY	DESCRIPTION	REMARKS
36.	168-035	1	IDLER GEAR	
37.	126-170	2	TAPERED BEARING (2.250")	
38.	126-171	2	TAPERED RACE (3.740")	
39.	166-152	1	ROTATION GEARBOX PLANETARY	SEE FOOTNOTE 1
40.	168-034	1	INPUT PINION	
41.	125-308	1	TAPERED BEARING (3.000")	
42.	125-309	1	TAPERED RACE (5.000")	
43.	115-025	1	PLUG (08N, SQ FM, MAG)	
44.	115-162	1	NIPPLE (08N-4")	
45.	115-155	1	COLLAR (08NF)	
46.	153-638	1	INTERNAL SEAL	
47.	106-755	14	SCREW (M10-1.50 X 30MM, SOC)	
48.	157-285	1	O-RING (238 D75 VITON)	

NOT SHOWN:

FOOTNOTES:

1. APPLY LOCTITE SUPERFLEX RED HIGH TEMP RTV OR EQUIVALENT - 3/16 DIA. MIN. BEAD.
2. THIS ITEM WILL COME IN GEARBOX. REMOVE AND INSTALL ITEMS 44,45,& 49.
3. 126-172 SUPERSEDED BY 125-1009. TIMKEN® 32222M WILL NOT WORK IN THIS APPLICATION.

NOTE:

SPINDLE DRIVE

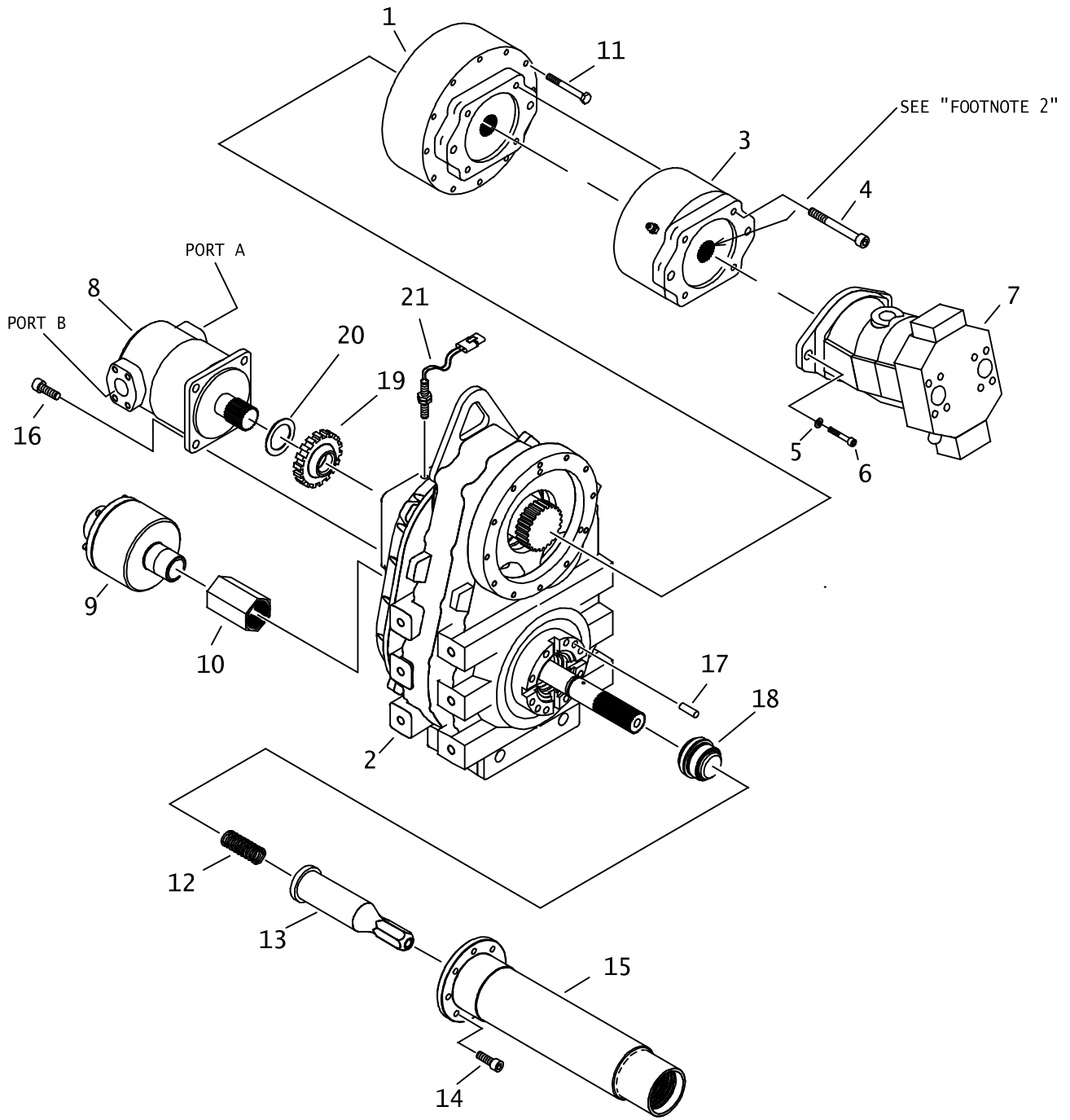

SPINDLE DRIVE

REF NO.	PART NUMBER	QTY	DESCRIPTION	REMARKS
	166-396	-	{AT} ROTATION DRIVE	AT ONLY, INCLUDES REF. #'S 1-8, & 11-21
	166-482	-	{JT} ROTATION DRIVE	JT ONLY, INCLUDES REF. #'S 1-7,11,14,15, & 17.
1.	166-152	-	ROTATION GEARBOX PLANETARY	
2.	166-488	-	{AT} ROTATION DRIVE GEARBOX	
	166-489	-	{JT} ROTATION DRIVE GEARBOX	
3.	160-1099	1	MODULAR BRAKE	APPLY ANTISIEZE AS INDICATED IN FOOTNOTE 2
	163-212	-	BLEEDER SCREW, DISC BRAKE	
	500-1283	-	OIL SEAL	
	191-169	-	STACK SERVICE KIT	
	191-167	-	GASKET KIT	
	191-168	-	BEARING KIT	
	191-166	-	O-RING KIT	
4.	107-495	4	BLT (1/2-NC X 4.50", SOC GD 8)	USE 242 LOCTITE; TORQUE TO 90 FT LBS
5.	106-398	2	WASHER (M16, HARDENED)	
6.	105-997	2	BOLT (5/8-NC X 1-3/4", SOC)	USE 242 LOCTITE; TORQUE TO 175 FT LBS
7.	158-059	1	HYD MOTOR	AT ONLY
	153-244	-	HYD MOTOR	JT ONLY
	214-886	-	SOLENOID COIL	
	502-172	-	HALL SPEED SENSOR	AT ONLY
8.	153-612	1	HYDRAULIC MOTOR	USE RED SILICON, AT ONLY
	191-263	AR	SEAL REPAIR KIT	
9.	153-208	1	WATER SWIVEL (24N-24NF)	SEE FOOTNOTE 5
10.	153-684	1	SPEC BUSHING (-26-24NF)	USE 567 LOCTITE, AT ONLY
11.	105-179	-	BOLT (3/8-NC X 3-1/2")	TORQUE TO 40 FT LBS
12.	117-541	1	SPRING	AT ONLY
13.	316-841	1	HEX	AT ONLY
14.	106-244	8	SCREW (M16-2.00 X 60MM, SOC)	USE 242 LOCTITE; TORQUE TO 225 FT LBS
15.	400-651	1	SAVER SUB	AT PIPE: SEE FOOTNOTE 3
	400-1135	1	SAVER SUB 3.25-4F SS	
	401-265	1	SAVER SUB ASSEMBLY SS 3.25-4F	SEE FOOTNOTE 4
	400-1133	1	SAVER SUB SS 3.25-4F	
	400-957	-	SAVER SUB ASSEMBLY 2.59-4F DS	JT PIPE
	400-1134	1	SAVER SUB 2.59-4F DS	
16.	105-282	4	BOLT (1/2-NC X 1-1/4", SOC)	USE 242 LOCTITE; TORQUE TO 90 FT LBS, AT ONLY
17.	500-818	2	DOWEL PIN (16MM X 40MM)	
18.	191-278	-	SEAL KIT	AT ONLY: SEE FOOTNOTE 3
	190-1163	-	SEAL KIT	SEE FOOTNOTE 4
19.	166-432	1	SPEED SENSOR RING	AT ONLY
20.	110-220	AR	MACH BUSHING (1-1/2", 14GA)	AT ONLY
21.	215-1472	1	PROXIMITY SWITCH 12MM WP	AT ONLY & REFER TO F/N 1 & F/N 6

NOT SHOWN:

FOOTNOTES:

1. INSTALL PROXIMITY SWITCH (REF. 21) TWO TURNS OUT FROM CONTACT WITH SPEED SENSOR RING (REF. 20).
2. APPLY ANTISIEZE TO INTERIOR OF SHAFT COUPLER ON THE BRAKE SECTION (REF. 4) WHERE THE ROTATION MOTOR (REF. 8) MOUNTS BEFORE ASSEMBLY.
3. ENDS WITH S/N: CMWA40T3P70000017
4. BEGINS WITH S/N: CMWA40T3K70000018
5. INSTALL USING NICKLE THREAD SEALING TAPE (117-555) ON MALE THREADS.
6. PROXIMITY SWITCH 215-1472 SUPERCEDES PROXIMITY SWITCH 214-913.

NOTE:

OUTER SPINDLE DRIVE CASE DRAIN

ENDS WITH S/N CMWJ40T3L7000025

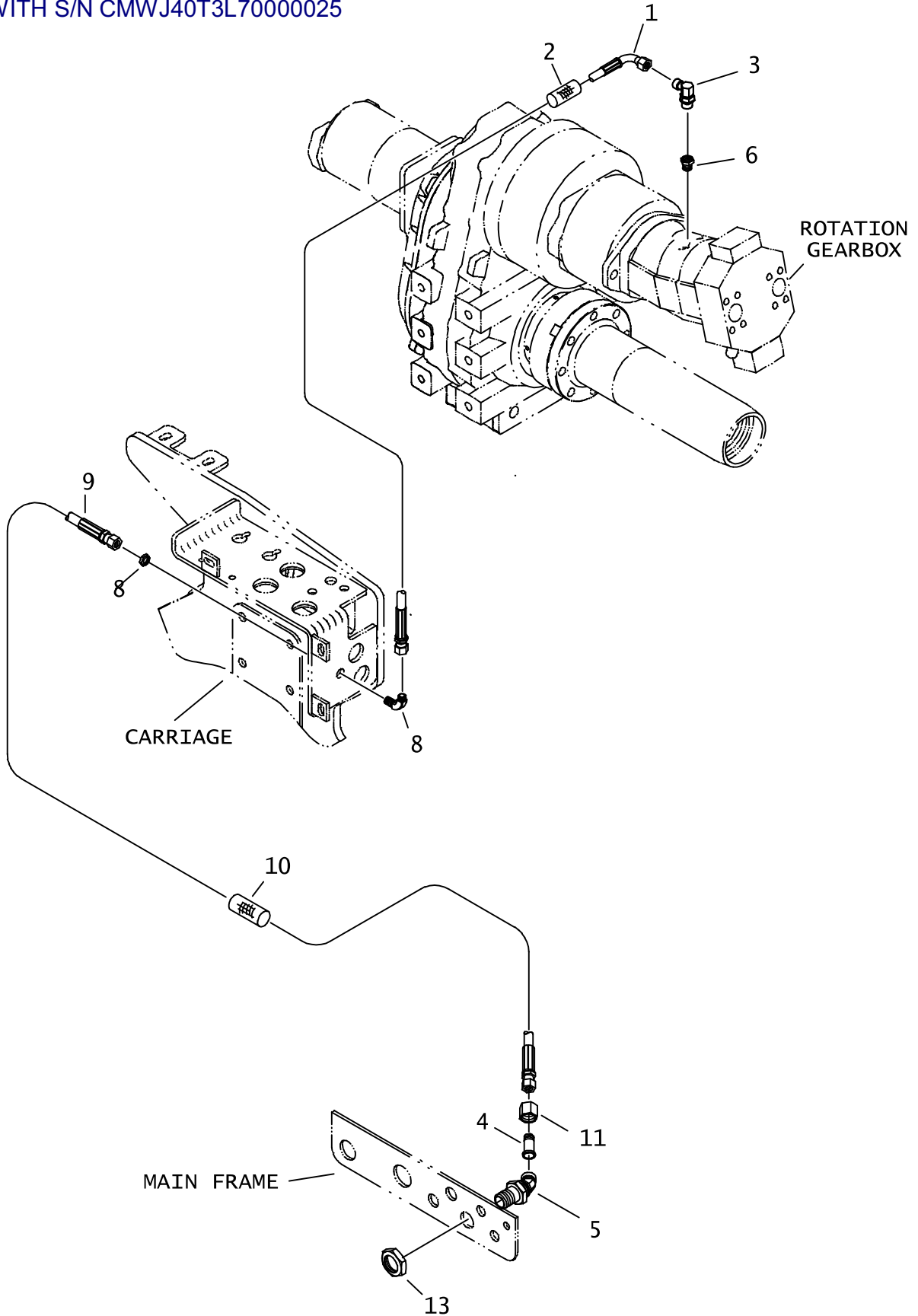

OUTER SPINDLE DRIVE CASE DRAIN

ENDS WITH S/N CMWJ40T3L70000025

REF NO.	PART NUMBER	QTY	DESCRIPTION	REMARKS
1.	153-768	1	HOSE (060FX90S-18"-3000)	
2.	117-328	1	ABRASION SLEEVE (1.00" X 18")	
3.	157-381	1	CONNECTOR (08S-06090s)	
4.	154-459	1	REDUCER STEM (060)	
5.	154-448	1	BK CONNECTOR (120-12045BK)	
6.	153-770	1	REDUCER (12S-08SF)	
8.	154-229	1	BK CONNECTOR (060-06090BK)	
9.	515-750	1	HOSE (060FX-210"-3000)	
10.	117-416	1	ABRASION SLEEVE (1.00" X 50")	
11.	154-271	1	REDUCER NUT (120F)	

NOT SHOWN:

FOOTNOTES:

NOTE:

HOSE TRACK

ENDS WITH S/N: CMWA40T3PB0000138
CMWJ40T3CB0000136

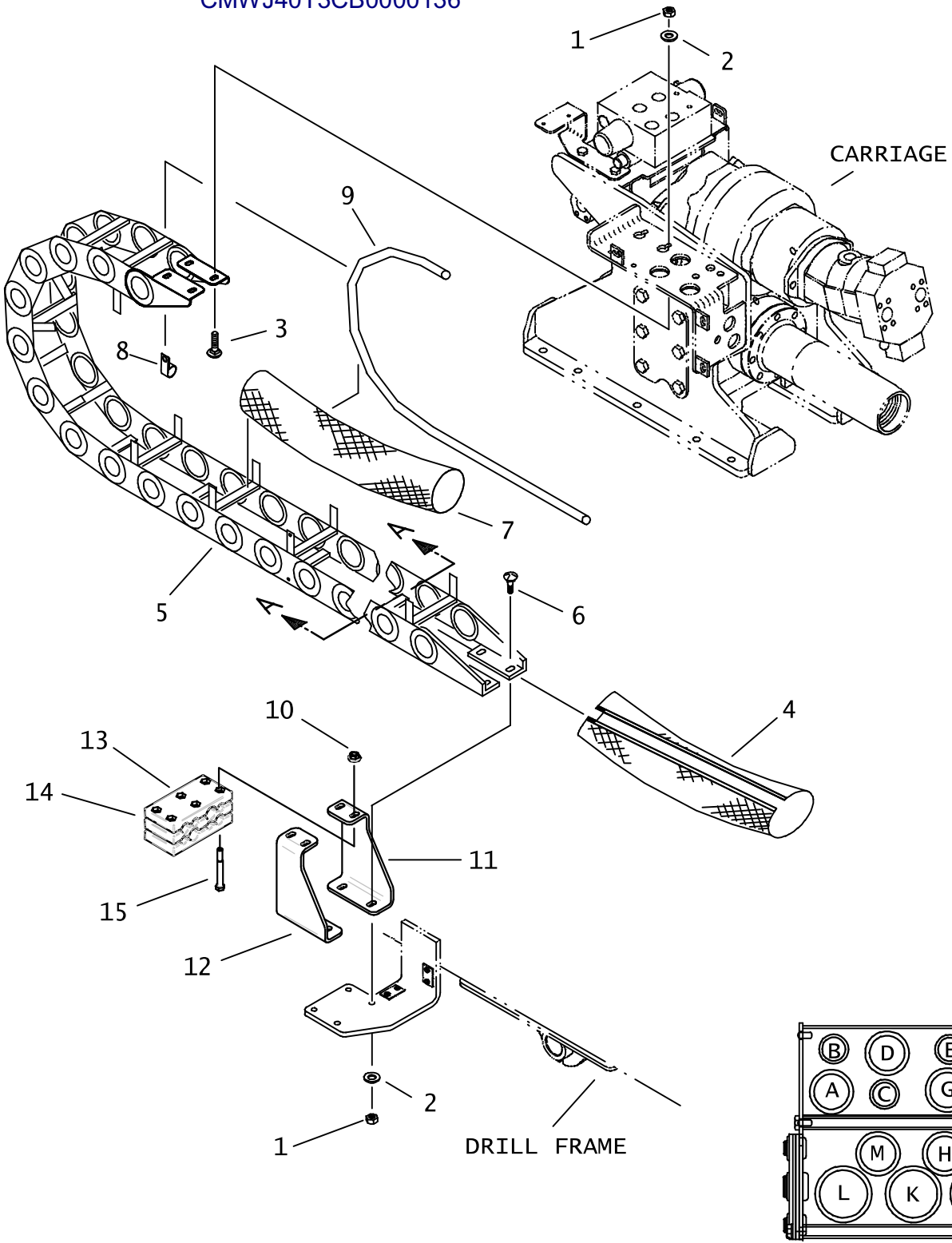

VIEW A-A
SEE NOT SHOWN

HOSE TRACK

ENDS WITH S/N: CMWA40T3PB0000138

CMWJ40T3CB0000136

REF NO.	PART NUMBER	QTY	DESCRIPTION	REMARKS
1.	105-047	8	LOCKNUT (3/8-NC)	
2.	105-117	6	WASHER (5/16")	
3.	105-600	4	CARRIAGE BOLT (3/8-NC X 1")	
4.	150-1787	-	HOSE BAG FOR 150-1750	4020 WITH RACK AND PINION ONLY
	117-919	-	HOSE BAG W/ELECT HARN PCK	USED ON I17-881 ONLY.
	117-991	-	HOSE BAG	
5.	150-1750	1	HOSE TRACK 4020 R&P	4020 WITH RACK AND PINION ONLY
	117-969	1	HOSE CARRIER	INCLUDES REF NO. 4 & 8.
	499-606	-	REPAIR SECTION, 4-LINK	SEE FOOTNOTE 1. FOR I17-969 AND 150-1750.
	499-604	-	BAR KIT	SEE FOOTNOTE 2. FOR I17-969 AND 150-1750.
	499-605	-	HARDWARE KIT	SEE FOOTNOTE 3. FOR I17-969 AND 150-1750.
	499-607	-	EXTENDER KIT	SEE FOOTNOTE 4. FOR I17-969 AND 150-1750.
	499-608	-	EASY OUT BAR KIT	SEE FOOTNOTE 6. FOR I17-969 AND 150-1750.
	499-567	-	MOUNTING BRACKET KIT	SEE FOOTNOTE 5.
	117-881	1	HOSE CARRIER	OBSOLETE
	499-563	-	REPAIR SECTION, 4-LINK	SEE FOOTNOTE 1. FOR I17-881 ONLY.
	499-564	-	BAR KIT	SEE FOOTNOTE 2. FOR I17-881 ONLY.
	499-565	-	HARDWARE KIT	SEE FOOTNOTE 3. FOR I17-881 ONLY.
	499-566	-	EXTENDER KIT	SEE FOOTNOTE 4. FOR I17-881 ONLY.
	499-568	-	EASY OUT BAR KIT	SEE FOOTNOTE 6. FOR I17-881 ONLY.
6.	107-566	4	CARRIAGE BOLT (3/8-NC X 1.50")	
7.	117-995	1	ABRASION SLEEVE (2.07" X 156")	SEE FOOTNOTE 7.
8.	110-333	1	BOLT-ON CLAMP (1")	SEE FOOTNOTE 7.
9.	117-378	1	BULK HOSE, LOW PRESSURE (-12)	USE 147.0". SEE FOOTNOTE 7.
10.	105-814	6	FLG LOCKNUT (3/8-NC)	
11.	300-8896	1	LEFT MOUNT BRACKET	
12.	300-8895	1	RIGHT MOUNT BRACKET	
13.	362-1408	2	CAP PLATE	
14.	362-1407	1	CENTER PLATE	
15.	105-081	6	BOLT (3/8-NC X 3-1/4")	

NOT SHOWN:

150-1701	A	HOSE (060FX-280"-3000)	
150-1700	B	HOSE (040FX45-282"-3000)	
150-1980	C	HOSE (040FX-282"-3000)	
150-1979	D	HOSE (080FX-289"-3000)	
150-1700	E	HOSE (040FX45-282"-3000)	AT ONLY
150-1709	F	HOSE(060FX45-302"-3000)	
215-1358	G	HOSE TRACK HARNESS	
150-1702	H	HOSE (160FX90S-299"-6000)	
150-1705	J	HOSE(200FX90L-300"-3000)	
150-1708	K	HOSE(200FX90S-283"-3000)	
150-1704	L	HOSE(200FX90S-287"-3000,SPEC)	
150-1702	M	HOSE (160FX90S-299"-6000)	

FOOTNOTES:

- 4-LINK REPAIR SECTION SUPPLIED ASSEMBLED WITH 8X LINK PINS AND SNAP RINGS SHIPPED LOOSE
- KIT CONTENTS: 8X ALUMINUM FLAT BARS, 32X 10-24 UNC SCREWS
- KIT CONTENTS: 8X LINK PINS, 8X LINK PIN SNAP RINGS
- KIT CONTENTS: 8X WINDOW EXTENDERS, 8X 1/4-20 UNC SCREWS AND NUTS
- KIT CONTENTS: 2X RIGHT AND LEFT MOUNTING BRACKETS, 8X LINK PINS, 8X LINK PIN SNAP RINGS
- KIT CONTENTS: 10X EASY-OUT BAR
- NOT USED ON 4020 WITH RACK AND PINION.

NOTE:

CLAMP ASSEMBLY AT42M1

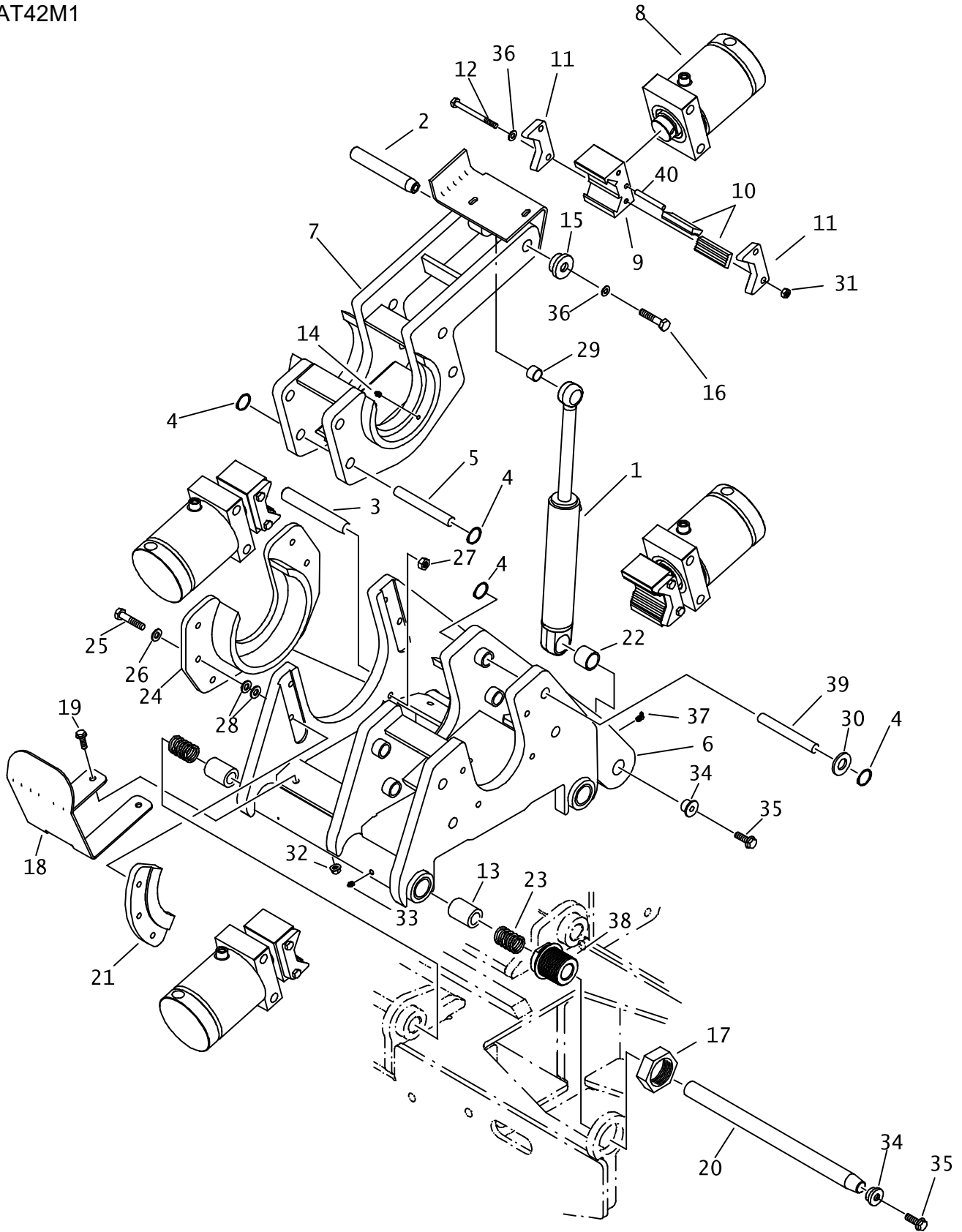

CLAMP ASSEMBLY AT42M1

REF NO.	PART NUMBER	QTY	DESCRIPTION	REMARKS
1.	151-031	1	CYL (2" X 1" X 8")	
2.	184-789	1	TAPERED PIN (25.4MM X 158.7MM)	
3.	178-075	1	TAPERED PIN (31.7MM X 240MM)	
4.	118-053	16	EXTERNAL SNAP RING (.875")	
5.	105-1133	4	PIN	APPLY ANTI-SEIZE TO PIN
6.	313-716	1	STATIONARY CLAMP	
7.	313-717	1	ROTATION CLAMP	
8.	151-212	4	CYL (4.50" X 2.25" X 2.75")	
9.	314-747	4	JAW BLOCK	
10.	350-446	8	GRIPPER INSERT	AT PIPE
	320-155	-	GRIPPER INSERT	JT PIPE
11.	313-881	8	PLATE	
12.	105-022	8	BOLT (3/8-NC X 4")	
13.	178-456	4	BUSHING 1.26ID X 1.75OD X 1.75	
14.	115-003	8	ZERK (1/4-NF, STR)	
15.	181-981	1	TAPERED INSERT (1")	
16.	105-245	1	SCREW (M10-1.50 X 25MM)	
17.	105-695	2	NUT (2 3/8-16 UNJ)	LOCTITE 242
18.	310-114	1	PLATE	
19.	106-383	2	FLG LK SCREW (M10-1.50 X 30MM)	
20.	178-906	2	TAPERED PIN (1.250" X 25.310")	
21.	314-363	2	BACKUP PLATE	
22.	125-771	1	COMPOSITION BUSHING (1.25")	
23.	117-297	4	COMPRESSION SPRING	
24.	313-715	1	RETAINER	
25.	106-659	7	SCREW (M12-1.75 X 55MM)	LOCTITE 242
26.	106-397	7	WASHER (M12, HARDENED)	
27.	106-685	1	LOCKNUT(M12-1.75,PRV TRQ,10.9)	
28.	110-096	14	MACHINERY BUSHING (1/2")	
29.	125-770	1	COMPOSITION BUSHING (1")	
30.	105-318	AR	WASHER (7/8")	INSTALL WASHERS SO THAT SLACK IS REMOVED
31.	105-047	8	LOCKNUT (3/8-NC)	LOCTITE 242
32.	106-387	2	FLG LOCKNUT (M10-1.50)	
33.	115-001	1	ZERK (O2N)	
34.	181-982	3	TAPERED INSERT (1.25")	
35.	106-469	3	FLG SCREW (M12-1.75 X 30MM)	
36.	106-396	8	WASHER (M10, HARDENED)	
37.	115-004	1	ZERK (O2N45)	
38.	178-283	2	BOSS	
39.	105-1134	4	PIN	APPLY ANTI-SEIZE TO PIN
40.	107-777	4	SPIRAL SPRING PIN (.375" X 3.00")	

NOT SHOWN:

FOOTNOTES:

NOTE:

WRENCH PIPE GUIDE

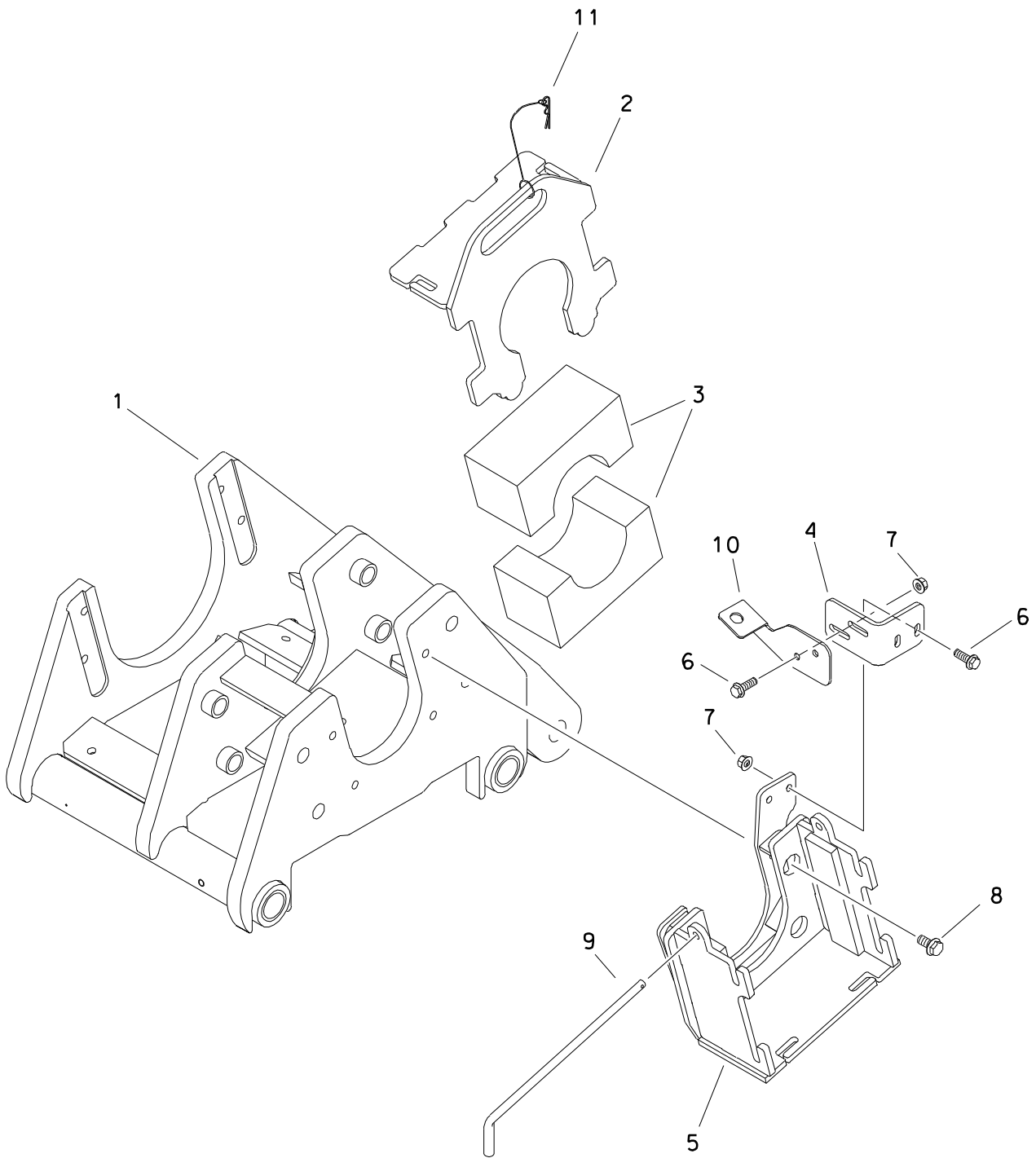

WRENCH PIPE GUIDE

REF NO.	PART NUMBER	QTY	DESCRIPTION	REMARKS
1.	313-716	-	STATIONARY CLAMP	
2.	313-761	1	BLOCK RETAINER	
3.	314-359	2	GUIDE BLOCK (4.13)	AT PIPE
	314-360	2	GUIDE BLOCK (3.50)	JT PIPE
4.	316-742	1	BRACKET, SPRAY	
5.	313-760	1	WRENCH GUIDE FRAME	
6.	106-724	4	FLG SCREW (M10-1.50 X 25MM)	
7.	106-387	4	FLG LOCKNUT (M10-1.50)	
8.	106-806	4	FLG LK SCREW (M12-1.75 X 25MM)	
9.	346-061	1	PIN	
10.	318-854	1	BRACKET, SPRAY	
11.	110-410	1	SAFETY CLIP & LANYARD	

FOOTNOTES

DRILLFRAME COVERS/LCKS/SWITCHES

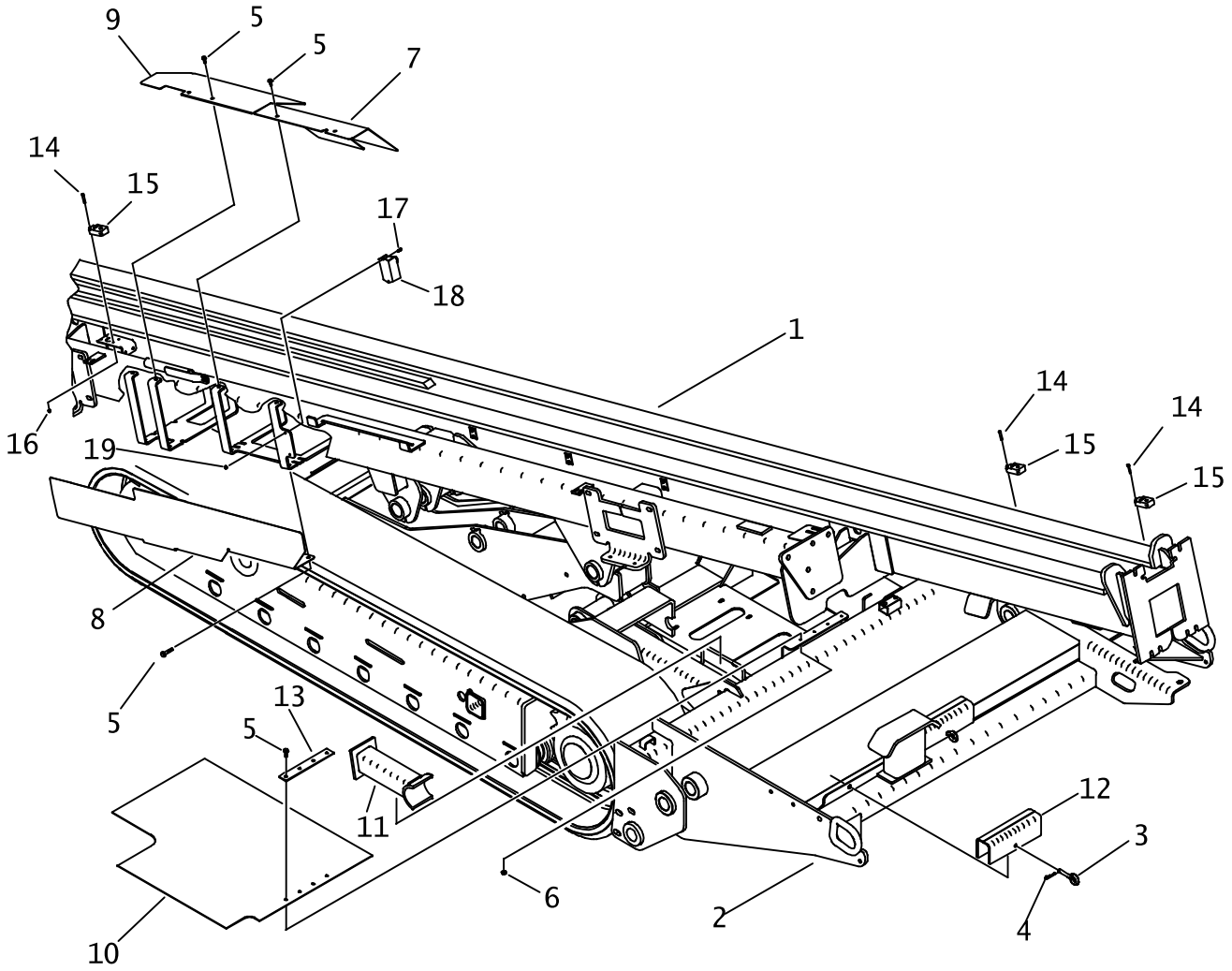

DRILLFRAME COVERS/LCKS/SWITCHES

REF NO.	PART NUMBER	QTY	DESCRIPTION	REMARKS
1.	303-423	-	DRILL FRAME	
2.	309-910	-	MAIN FRAME	
3.	110-034	2	EYE PIN (7/16" X 3")	
4.	110-033	2	HAIR CLIP PIN (1/8" X ")	
5.	106-991	12	FLG LK SCREW (M8-1.25 X 20MM)	
6.	106-561	4	LOCKNUT (M8-1.25, PRV TRQ, 10.9)	
7.	305-948	1	VALVE COVER	
8.	305-949	1	VALVE COVER	
9.	305-947	1	VALVE COVER	
10.	116-863	1	COVER FLAP	
11.	354-562	1	DRILL FRAME STIFF LEG	
12.	354-980	2	CYLINDER LOCK	
13.	350-514	1	CLAMP PLATE	
14.	107-465	6	SCREW (M5-0.80 X 30MM, SOC)	
15.	214-692	3	PROXIMITY SWITCH	
16.	106-850	6	LOCKNUT (M5-0.80)	
17.	106-542	2	SCREW (M5-0.80X16MM, PAN PLPS)	
18.	211-025	-	IN-LINE DIODE PACK	
19.	106-850	2	LOCKNUT (M5-0.80)	

NOT SHOWN:

107-451 AR SHIM (.135")
213-103 1 PULLBACK HARNESS

FOOTNOTE 1

FOOTNOTES:

I. FOR REAR STOP RETROFIT KIT ORDER KIT #599-303

NOTE:

GREASE CYLINDER

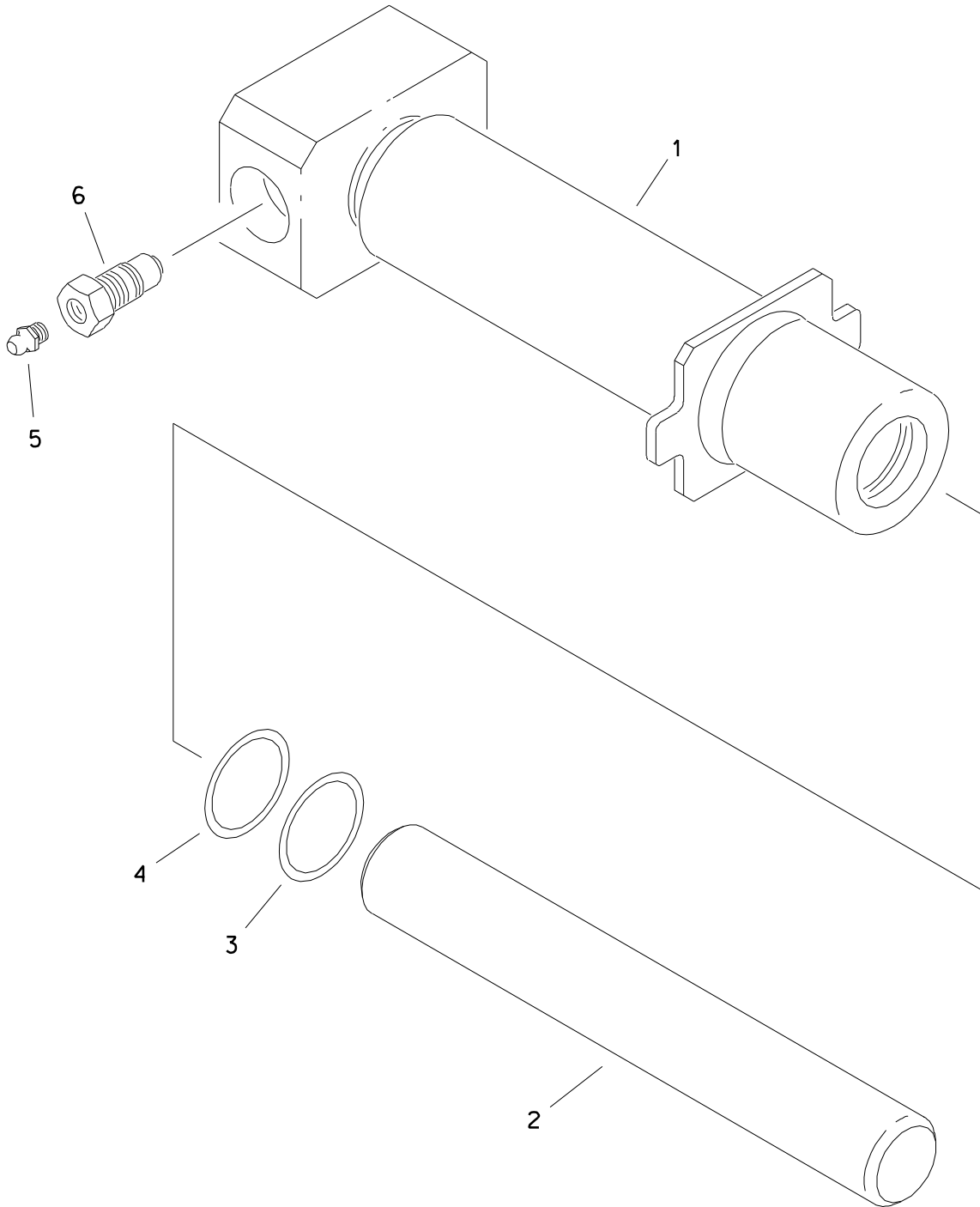

GREASE CYLINDER

REF NO.	PART NUMBER	QTY	DESCRIPTION	REMARKS
	151-165		GREASE CYLINDER	INCL REF NO'S 1 - 6
1.	353-404	1	GREASE CYLINDER	
2.	153-534	1	GREASE CYLINDER ROD	
3.	155-732	1	BACKUP RING (224 D90)	
4.	155-704	1	O-RING (224 D70)	
5.	115-019	1	ZERK (Q2N)	
6.	159-093	1	RELIEF VALVE (5/8-NF, Q2N)	

FOOTNOTES

HYDRAULIC CYLINDER (4.50" X 2.25" X 2.75")

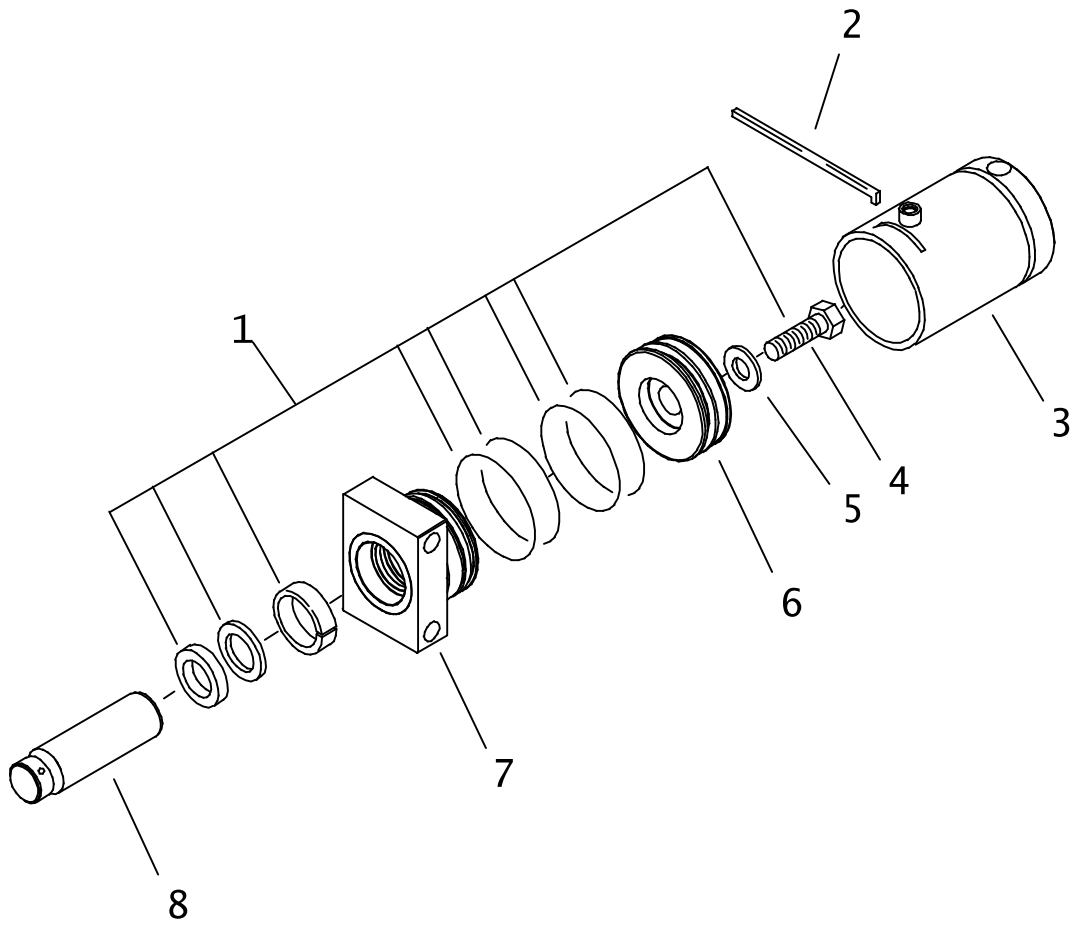

HYDRAULIC CYLINDER (4.50" X 2.25" X 2.75")

REF NO.	PART NUMBER	QTY	DESCRIPTION	REMARKS
	151-212		CYLINDER ASSEMBLY	INCLUDES REF NO'S 2 THRU 8
1.	190-900	1	SEAL REPAIR KIT	
2.	150-711	1	LOCK RING	
3.	152-073	1	4.5 X 2.75 BARREL	
4.	106-146	1	BOLT (1-1/8-NC X 2-1/2", GD8)	SEE FOOTNOTE 1
5.	106-147	1	WASHER (1-1/8")	
6.	149-168	1	4.5 X 2.25 PISTON	SEE FOOTNOTE 2
7.	151-207	1	GLAND	
8.	153-753	1	CYLINDER ROD	

NOT SHOWN
259-040 U-SEAL INSTALLER (1.500" - UP)

FOOTNOTES

1. USE LOCTITE 271 OR 277. TORQUE TO 770-850 FT-LBS (1045-1150 N.M.).
2. UNITIZED PISTON INCLUDES WEAR RINGS, SQUARE LOADER RING & PISTON SEAL.

NOTE:

PIPE LOADER SYSTEMS

PIPE LOADER SHUTTLE DRIVE

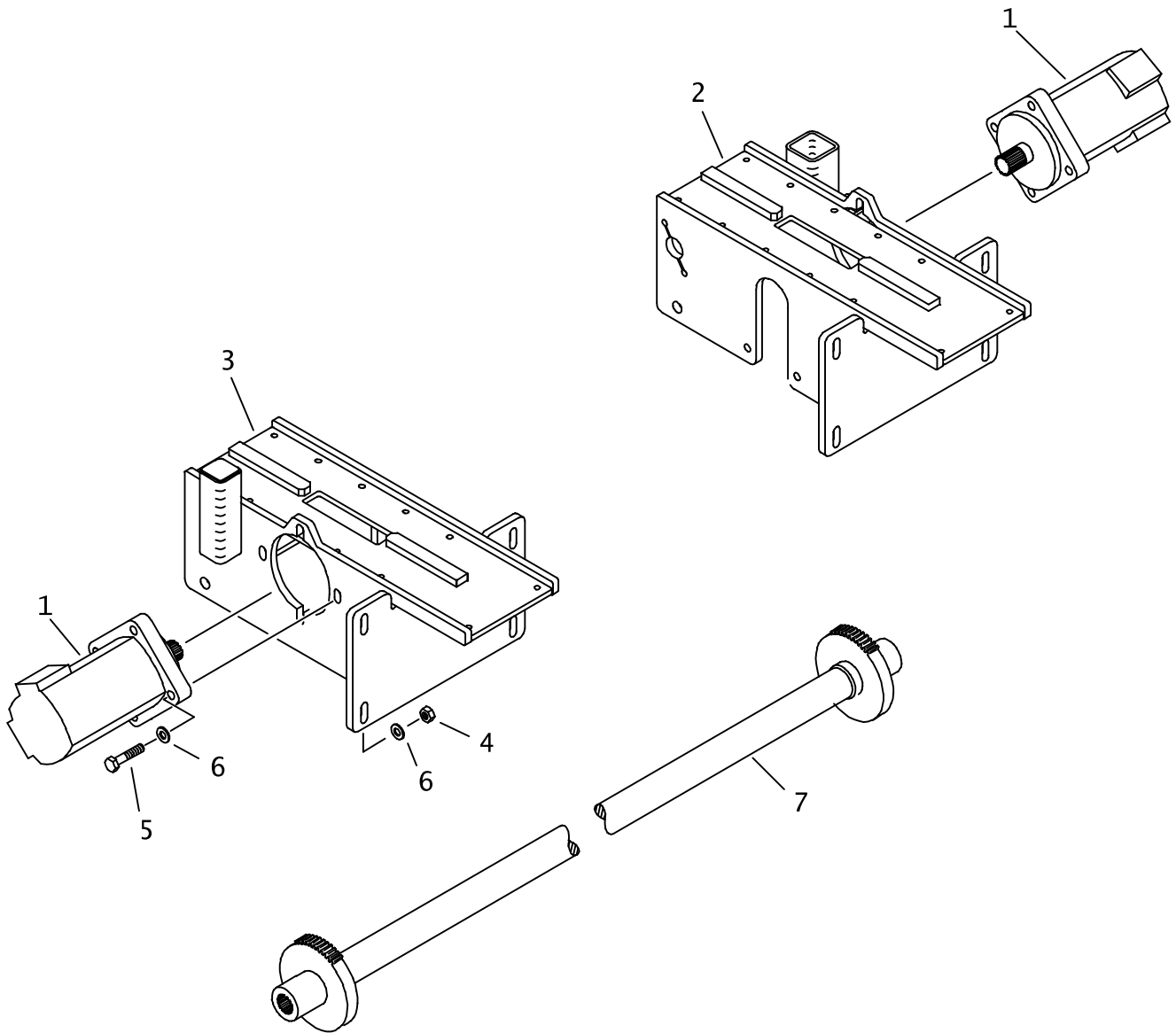

PIPE LOADER SHUTTLE DRIVE

REF NO.	PART NUMBER	QTY	DESCRIPTION	REMARKS
1.	158-026	2	HYDRAULIC MOTOR (15 CU/IN)	
	500-1552	-	SEAL REPAIR KIT	
	500-1553	-	SHAFT AND BEARING KIT	
	500-711	-	SEAL REPAIR KIT, REAR	
	500-758	-	SEAL REPAIR KIT, SHAFT	
2.	307-591	-	FRONT SHUTTLE SUPPORT	
	327-1063	-	FRONT SHUTTLE SUPPORT	SEE FOOTNOTE I
3.	307-592	-	REAR SHUTTLE SUPPORT	
	327-1064	-	REAR SHUTTLE SUPPORT	SEE FOOTNOTE I
4.	106-685	8	LOCKNUT (M12-1.75, PRV TRQ, 10.9)	
5.	106-594	8	SCREW (M12-1.75 X 60MM)	
6.	106-397	16	WASHER (M12, HARDENED)	
7.	313-969	1	PINION SHAFT	

NOT SHOWN:

FOOTNOTES:

I. USE ON 4020 WITH RACK AND PINION

NOTE:

PIPE LOADER LIFTERS

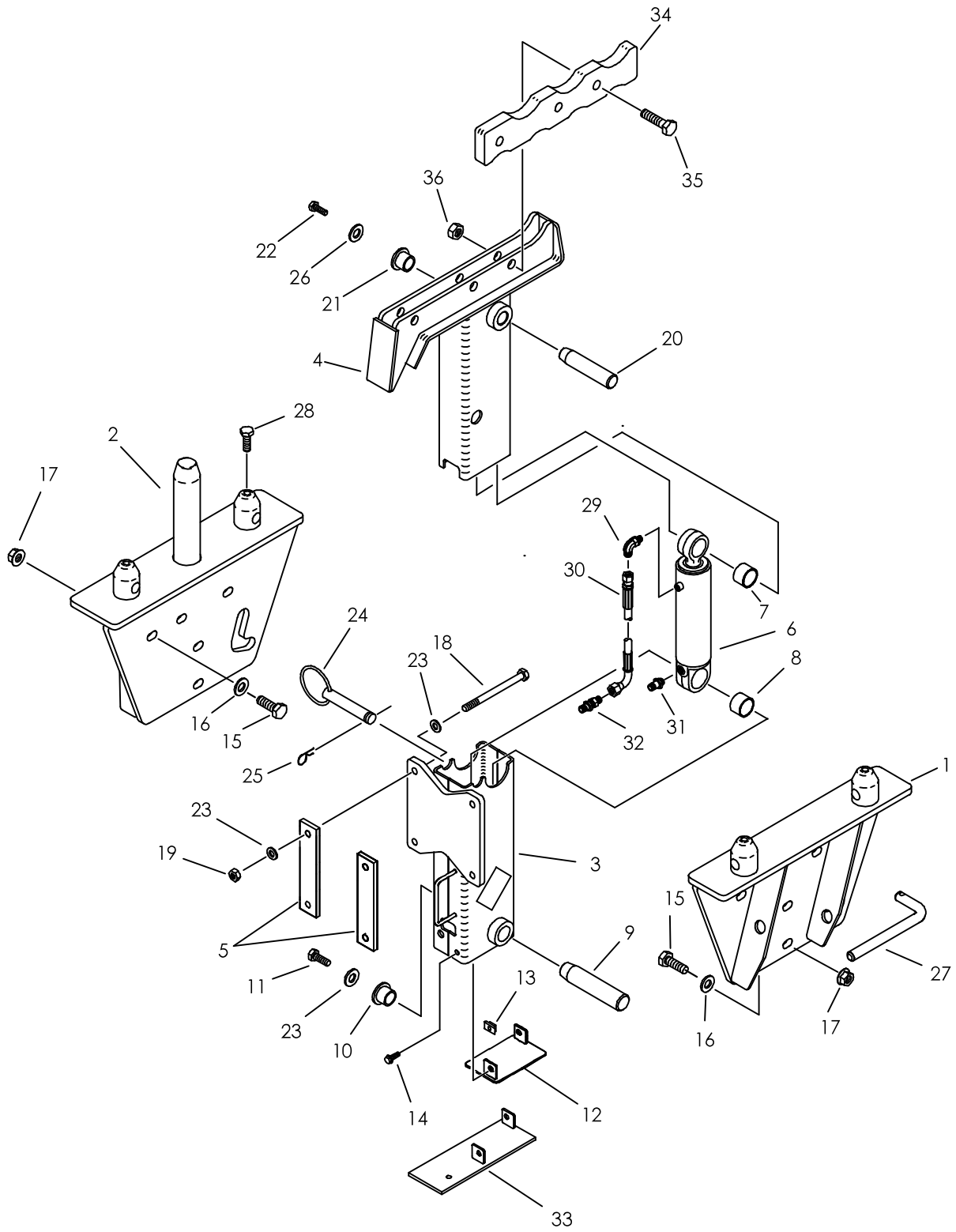

PIPE LOADER LIFTERS

REF NO.	PART NUMBER	QTY	DESCRIPTION	REMARKS
1.	313-792	1	FRONT BOX SUPPORT	
2.	313-791	1	REAR BOX SUPPORT	
3.	313-783	2	LIFTER OUTER TUBE	
4.	313-805	2	PIPE LIFTER	
	327-1069	2	PIPE LIFTER	SEE FOOTNOTE 2
5.	354-338	4	MOUNT PLATE	
6.	151-031	2	CYL (2.0" X 1.00" X 8.000")	
7.	125-770	2	COMPOSITION BUSHING (1")	
8.	125-771	2	COMPOSITION BUSHING (1.25")	
9.	183-863	2	TAPERED PIN (31.7MM X 128MM)	
10.	181-982	2	TAPERED INSERT (1.25")	
11.	105-273	2	SCREW (M12-1.75 X 30mm)	
12.	356-297	1	STABILIZER CAP	REAR LIFTER
13.	106-551	4	CLIP NUT (M8-1.25)	
14.	106-991	4	FLG LK SCREW (M8-1.25 X 20mm)	
15.	106-340	10	SCREW (M16-2.00 X 50mm)	
16.	106-398	10	WASHER (M16, HARDENED)	
17.	106-442	10	FLG LOCKNUT (M16-2.00, PRV TRQ)	
18.	106-620	8	SCREW (M12-1.75 X 150mm)	
19.	106-685	8	LOCKNUT (M12-1.75, PRV TRQ, 10.9)	
20.	179-024	2	TAPERED PIN (25.4MM X 117MM)	
21.	181-981	2	TAPERED INSERT (1.00")	
22.	105-245	2	SCREW (M10-1.50 X 25mm)	
23.	106-397	18	WASHER (M12, HARDENED)	
24.	180-559	2	PULL PIN (1" X 4.625")	
25.	110-128	2	SPRING CLIP PIN (5/32" X 1")	
26.	106-396	2	WASHER (M10, HARDENED)	
27.	178-446	2	PIPE ROTATION PIN	JT ONLY
28.	106-477	4	SCREW (M12-1.75 X 45MM, 10.9)	
29.	154-252	-	CONNECTOR (04S-04090)	
30.	515-179	-	HOSE (040FX90-11"-3000)	
31.	154-403	-	CONNECTOR (04S-040, XL)	
32.	154-275	-	BK CONNECTOR (040-040BK)	
33.	306-741	1	CAP	FRONT LIFTER
34.	313-782	2	PIPE LIFTER INSERT	SEE FOOTNOTE 1
	300-7416	2	PIPE LIFTER INSERT	SEE FOOTNOTE 1 & 2
35.	106-341	6	SCREW (M16-2.00 X 70MM)	
36.	106-545	6	LOCKNUT (M16-2.0, PRV TRQ, 10.9)	

NOT SHOWN:

FOOTNOTES:

- PIPE LIFTER INSERT IS REVERSABLE. SIDE W/ 3 NOTCHES IS FOR THE AT, SIDE W/ 4 NOTCHES IS FOR JT.
- USE ON 4020 WITH RACK AND PINION.

NOTE:

FRONT PIPE LOADER SHUTTLE

JT42 T3, AT42 T3

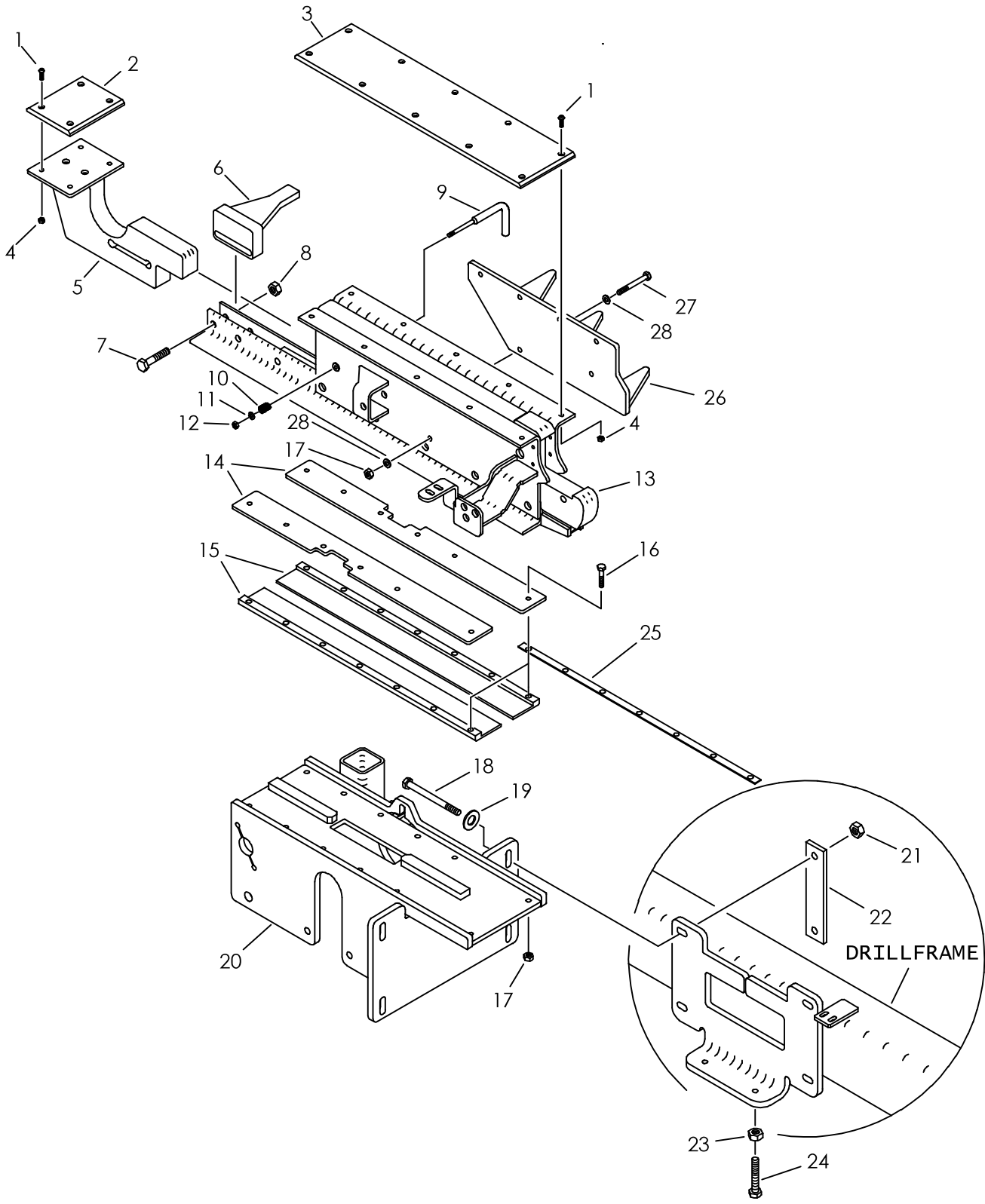

FRONT PIPE LOADER SHUTTLE

JT42 T3, AT42 T3

REF NO.	PART NUMBER	QTY	DESCRIPTION	REMARKS
1.	106-640	14	SCREW (M6-1.00 X 20MM,BUT SOC)	
2.	307-623	1	PIPE SLIDE BEARING	
3.	315-112	1	PIPE SLIDE BEARING	
4.	106-237	14	LOCKNUT (M6-1.00,PRV TRQ,NLK)	
5.	313-685	1	SINGLE PIPE LOADER	
6.	307-594	1	SHUTTLE STOP	
7.	106-659	2	SCREW (M12-1.75 X 55MM)	
8.	106-685	2	LOCKNUT(M12-1.75,PRV TRQ,10.9)	
9.	178-414	1	SHOULDER PIN	
10.	117-116	1	COMPRESSION SPRING	
11.	105-095	1	WASHER (1/4")	
12.	105-085	1	LOCKNUT (1/4-NC)	
13.	313-683	1	FRONT SHUTTLE	
14.	307-605	2	PLATE	
15.	307-621	2	SHUTTLE SLIDE BEARING	
16.	106-328	12	SCREW (M8-1.25 X 40MM)	
17.	106-561	17	LOCKNUT (M8-1.25,PRV TRQ,10.9)	
18.	107-213	4	SCREW (M12-1.75 X 160MM)	
19.	106-397	4	WASHER (M12, HARDENED)	
20.	307-591	1	FRONT SHUTTLE SUPPORT	
	327-1063	1	FRONT SHUTTLE SUPPORT	SEE FOOTNOTE I
21.	106-685	4	LOCKNUT(M12-1.75,PRV TRQ,10.9)	
22.	354-338	2	MOUNT PLATE	
23.	106-089	2	NUT (M12-1.75, 10.9)	
24.	107-701	2	SCREW (M12-1.75 X 100MM)	
	105-1079	2	SCREW (M12-1.75 X 140MM)	SEE FOOTNOTE I
25.	117-539	AR	SHIM	USE ONLY IF PLASTIC IS TOO THIN
26.	313-701	1	AT ROW SELECT	
	313-702	1	JT ROW SELECT	
27.	105-292	5	SCREW (M8-1.25 X 75MM)	
28.	106-395	10	WASHER (M8, HARDENED)	

NOT SHOWN:

FOOTNOTES:

I. USE ON 4020 WITH RACK AND PINION

NOTE:

REAR PIPE LOADER SHUTTLE AT42M1

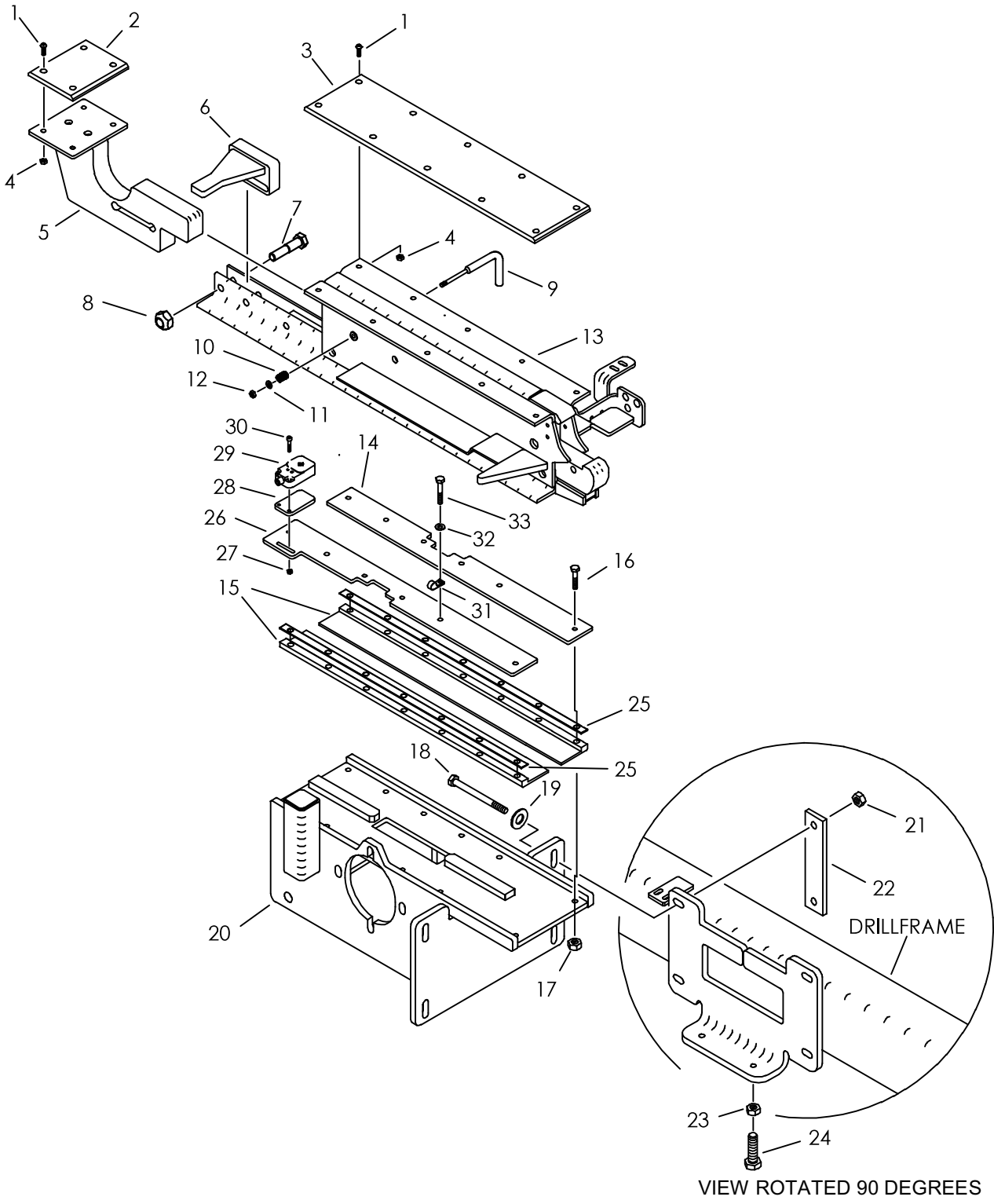

REAR PIPE LOADER SHUTTLE AT42M1

REF NO.	PART NUMBER	QTY	DESCRIPTION	REMARKS
1.	106-640	14	SCREW (M6-1.00 X 20MM,BUT SOC)	
2.	307-623	1	PIPE SLIDE BEARING	
3.	315-112	1	PIPE SLIDE BEARING	
4.	106-237	14	LOCKNUT (M6-1.00,PRV TRQ,NLK)	
5.	313-685	1	SINGLE PIPE LOADER	
6.	307-594	1	SHUTTLE STOP	
7.	106-659	2	SCREW (M12-1.75 X 55MM)	
8.	106-685	2	LOCKNUT(M12-1.75,PRV TRQ,10.9)	
9.	178-414	1	SHOULDER PIN	
10.	117-116	1	COMPRESSION SPRING	
11.	105-095	1	WASHER (1/4")	
12.	105-085	1	LOCKNUT (1/4-NC)	
13.	313-684	1	REAR SHUTTLE	
14.	307-605	1	PLATE	
15.	307-621	2	SHUTTLE SLIDE BEARING	
16.	106-328	11	SCREW (M8-1.25 X 40MM)	
17.	106-561	12	LOCKNUT (M8-1.25,PRV TRQ,10.9)	
18.	107-213	4	SCREW (M12-1.75 X 160MM)	
19.	106-397	4	WASHER (M12, HARDENED)	
20.	307-592	1	REAR SHUTTLE SUPPORT	
	327-1064	1	REAR SHUTTLE SUPPORT	SEE FOOTNOTE I
21.	106-685	4	LOCKNUT(M12-1.75,PRV TRQ,10.9)	
22.	354-338	2	MOUNT PLATE	
23.	106-089	2	NUT (M12-1.75, 10.9)	
24.	107-701	2	SCREW (M12-1.75 X 100MM)	
	105-1079	2	SCREW (M12-1.75 X 140MM)	SEE FOOTNOTE I
25.	117-539	AR	SHIM	USE ONLY IF PLASTIC IS TOO THIN
26.	307-947	1	PLATE	
27.	106-850	2	LOCKNUT (M5-0.80)	
28.	107-451	AR	SHIM (.135")	USE ONLY IF GAP IS TOO LARGE
29.	215-1175	-	PROXIMITY SENSOR	
30.	107-465	2	SCREW (M5-0.80 X 30MM, SOC)	
31.	110-259	1	BOLT-ON CLAMP (.625")	
32.	106-389	1	WASHER (M8)	
33.	106-932	1	SCREW (M8-1.25 X 45MM)	

NOT SHOWN:

FOOTNOTES:

I. USE ON 4020 WITH RACK AND PINION

NOTE:

PIPE LOADER GRIPPER

JT42 T3, AT42 T3

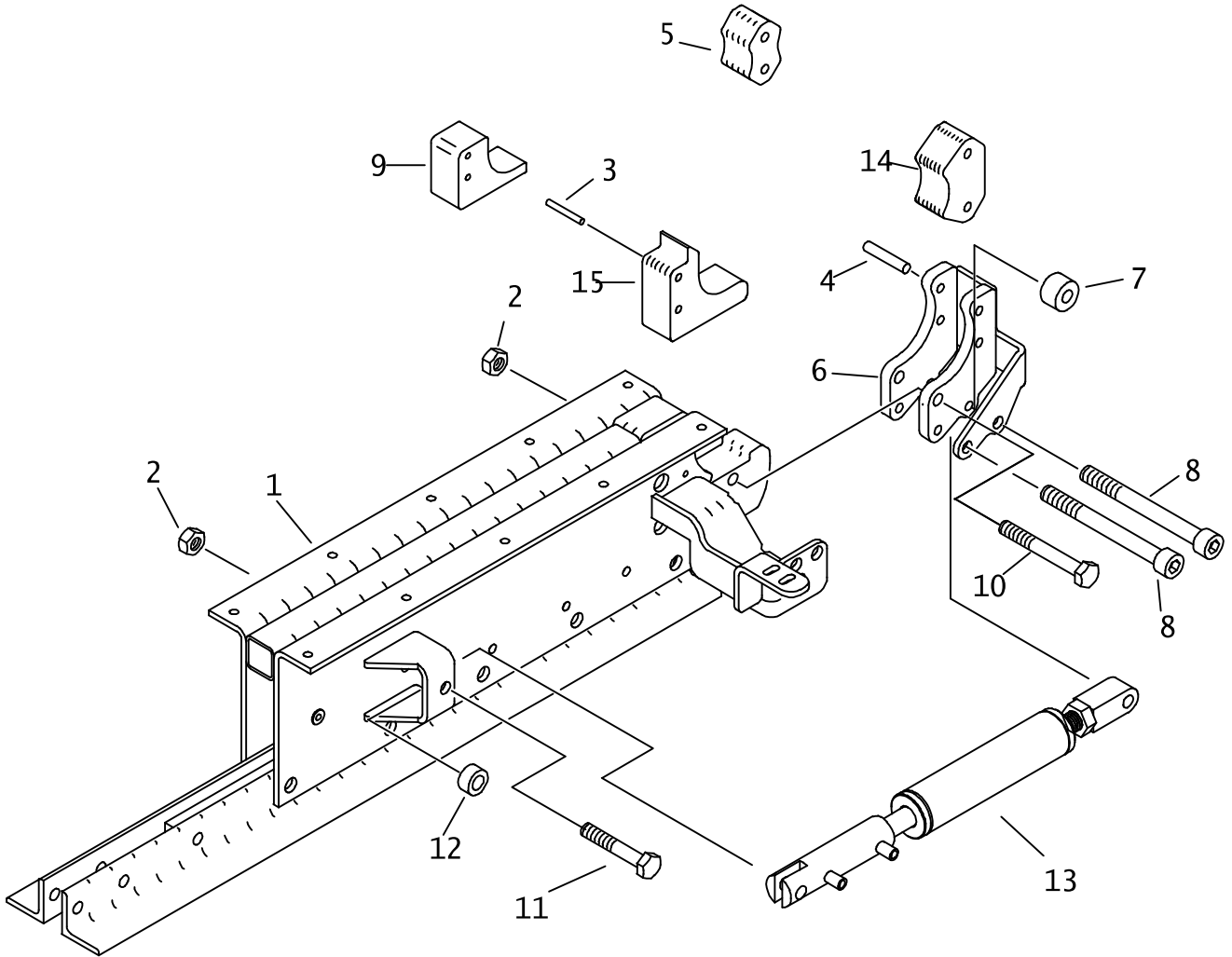

PIPE LOADER GRIPPER

JT42 T3, AT42 T3

REF NO.	PART NUMBER	QTY	DESCRIPTION	REMARKS
1.	313-683	1	FRONT SHUTTLE	
	313-684	1	REAR SHUTTLE	
2.	105-065	4	LOCK NUT (1/2-NC)	
3.	105-503	4	ROLL PIN (1/4" X 2")	
4.	105-555	4	ROLL PIN (3/8" X 2-1/2")	
5.	313-705	2	GRIPPER PAD	USE WITH AT PIPE
6.	313-686	1	FRONT GRIPPER	
	313-687	1	REAR GRIPPER	
7.	307-614	2	ROLLER	
8.	107-613	4	SHLD BLT M12 X 40MM, M10-1.50,SP	LOCTITE 277
9.	313-704	2	SHUTTLE PAD	USE WITH AT PIPE
10.	105-300	2	BOLT (1/2-NC X 3-1/4")	
11.	105-472	2	BOLT (1/2-NC X 5")	
12.	354-354	2	SPACER	
13.	191-161	2	GRIPPER CYLINDER	
14.	319-369	2	GRIPPER PAD	USE WITH JT PIPE
15.	319-368	2	SHUTTLE PAD	USE WITH JT PIPE

NOT SHOWN:

FOOTNOTES:

NOTE:

GRIPPER CYLINDER

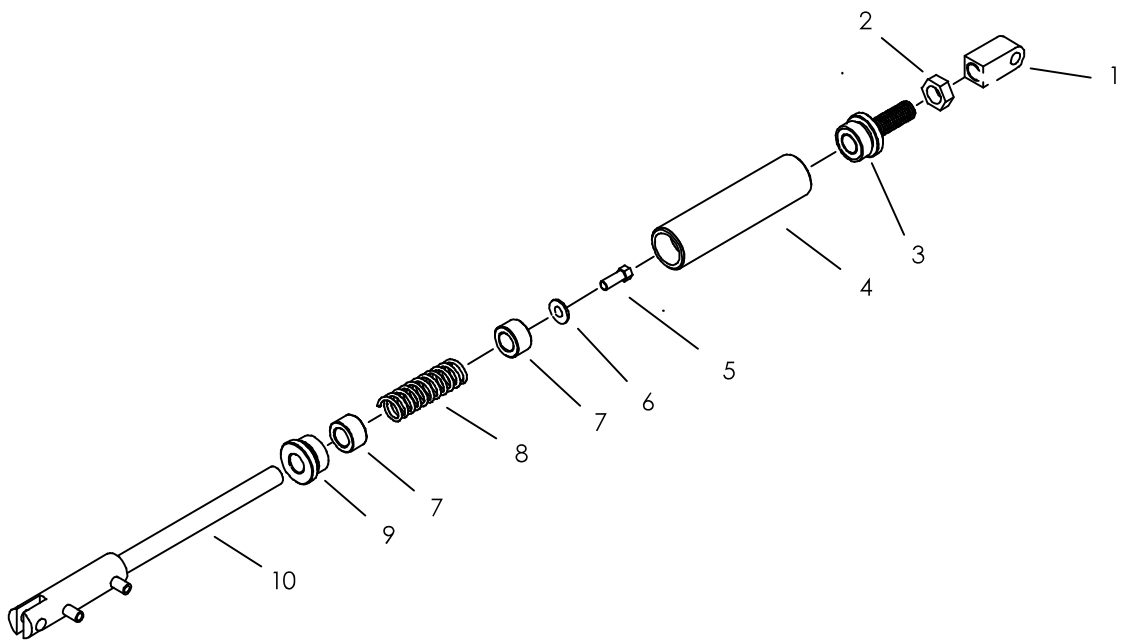

GRIPPER CYLINDER

REF NO.	PART NUMBER	QTY	DESCRIPTION	REMARKS
	191-161		GRIPPER CYLINDER	INCL. REF. NO.'S 1 THRU 10
1.	354-357	1	ROD END	
2.	105-310	1	JAM NUT (3/4-NC)	
3.	354-323	1	PLUNGER	
4.	354-355	1	TUBE	
5.	105-031	1	BOLT (3/8-NC X 1")	LOCKTITE 242
6.	105-118	1	WASHER (3/8")	
7.	354-356	2	SPRING GUIDE	
8.	117-180	1	COMPRESSION SPRING	
9.	354-432	1	CAP	
10.	150-731	1	CYL ASS'Y	USE HIGH TEMP PHILLIP GREASE ON ROD

NOT SHOWN:

FOOTNOTES:

NOTE:

SHUTTLE STOP

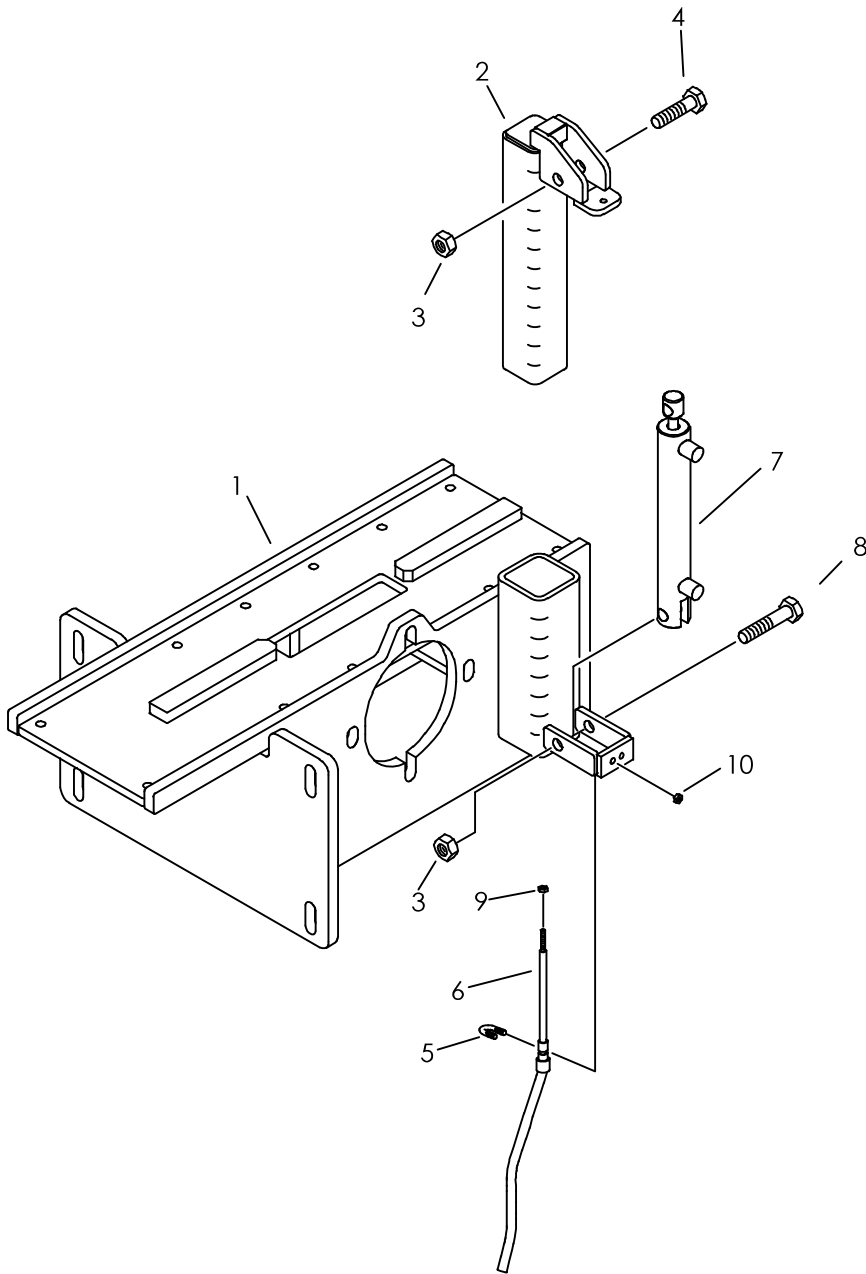

SHUTTLE STOP

REF NO.	PART NUMBER	QTY	DESCRIPTION	REMARKS
1.	327-1063	-	FRONT SHUTTLE SUPPORT	SEE FOOTNOTE 1
2.	308-344	1	STOP TUBE WELDMENT	
3.	105-065	2	LOCKNUT (1/2-NC)	
4.	105-002	1	BOLT (1/2-NC X 2-1/4")	
5.	106-630	1	U-BOLT (#10-24 X 5/16")	
6.	196-286	1	CONTROL CABLE	
7.	150-727	1	CYL (1.0" X .500" X 4.0")	
8.	105-067	1	BOLT (1/2-NC X 2-3/4")	
9.	106-138	2	NUT (M5-0.80)	
10.	105-186	2	NUT (#10-24)	

NOT SHOWN:

FOOTNOTES:
 1. USE ON 4020 WITH RACK & PINION

NOTE:

SHUTTLE STOP INDICATOR

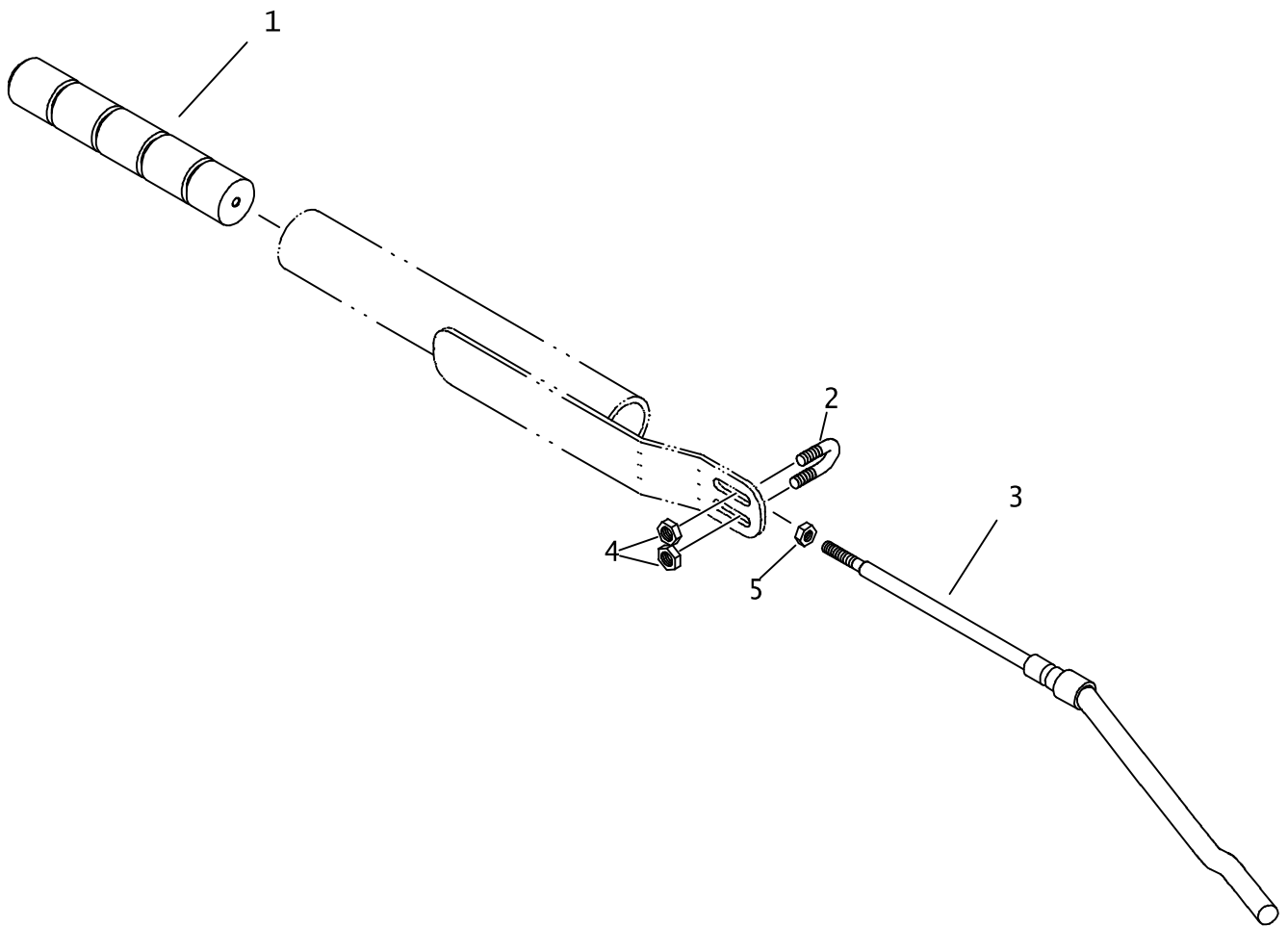

SHUTTLE STOP INDICATOR

REF NO.	PART NUMBER	QTY	DESCRIPTION	REMARKS
1.	258-032	1	ROW SELECT INDICATOR	
2.	106-630	1	U-BOLT (#10-24 X 5/16")	
3.	196-286	-	CONTROL CABLE	
4.	105-186	2	NUT (#10-24)	
5.	106-138	1	NUT (M5-0.80)	

NOT SHOWN:

FOOTNOTES:

NOTE:

PIPE BOX AT42T2 PIPE

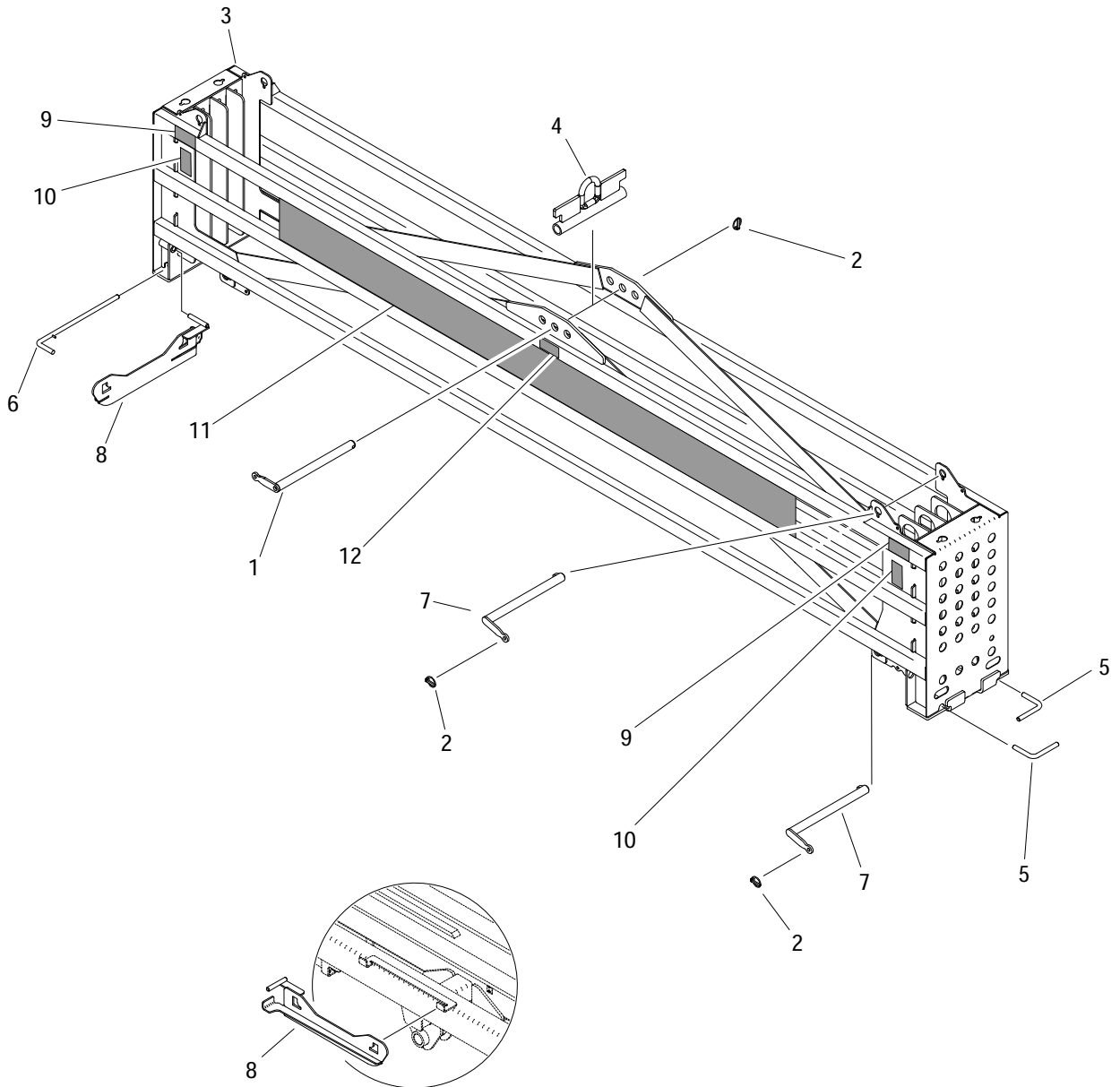
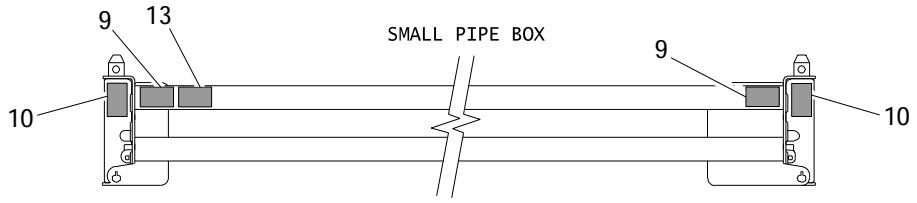

PIPE BOX AT42T2 PIPE

REF NO.	PART NUMBER	QTY	DESCRIPTION	REMARKS
	315-982		LARGE PIPE BOX ASS'Y	PARTS ASSEMBLY, INCLUDES ITEMS 1-12
	315-981		SMALL PIPE BOX PARTS ASS'Y	PARTS ASSEMBLY, INCLUDES ITEMS 1-10 & #13.
1.	308-084	1	LIFT PIN	
2.	110-228	5	LYNCH PIN (7/16"x2")	
3.	313-939	1	AT4020 PIPE BOX (TALL)	PART OF 315-982
	313-955	1	AT4020 PIPE BOX (SHORT)	PART OF 315-981
4.	314-574	1	LIFT PIN BLOCK	
5.	178-445	2	REAR PIN	
6.	308-091	1	FRONT PIN	
7.	308-086	4	SUPPORT PIN	
8.	308-868	1	SINGLE PIPE GUIDE	
9.	275-326	4	WARNING CRUSHING WEIGHT	USE 701-326 IN ALL FOREIGN KITS
10.	275-184	4	WARNING MOVING PARTS	USE 701-184 IN ALL FOREIGN KITS
11.	273-596	1	JT4020AT PIPE BOX MODEL-ID	
12.	273-373	1	LG PIPE BOX WEIGHTS	PART OF 315-982
13.	273-372	1	SM PIPE BOX WEIGHTS	PART OF 315-981

FOOTNOTES

PIPE BOX JT42T2 PIPE

REF NO.	PART NUMBER	QTY	DESCRIPTION	REMARKS
	310-361		LARGE PIPE BOX	PARTS ASSEMBLY, INCLUDES ITEMS 1-11
	309-912		SMALL PIPE BOX	PARTS ASSEMBLY, INCLUDES ITEMS 1-10
1.	308-084	1	LIFT PIN	
2.	110-228	5	LYNCH PIN (7/16"X2")	
3.	308-082	1	PIPE BOX	PART OF 310-361
	309-709	1	PIPE BOX	PART OF 309-912
4.	308-083	1	LIFT PIN BLOCK	
5.	178-445	2	REAR PIN	
6.	308-091	1	FRONT PIN	
7.	308-086	4	SUPPORT PIN	
8.	308-868	1	SINGLE PIPE GUIDE	
9.	275-326	4	WARNING CRUSHING WEIGHT	USE 701-326 IN ALL FOREIGN KITS
10.	275-184	4	WARNING MOVING PARTS	USE 701-184 IN ALL FOREIGN KITS
11.	273-538	1	MODEL ID W/ LOGOTYPE	

FOOTNOTES

SHUTTLE GUARD

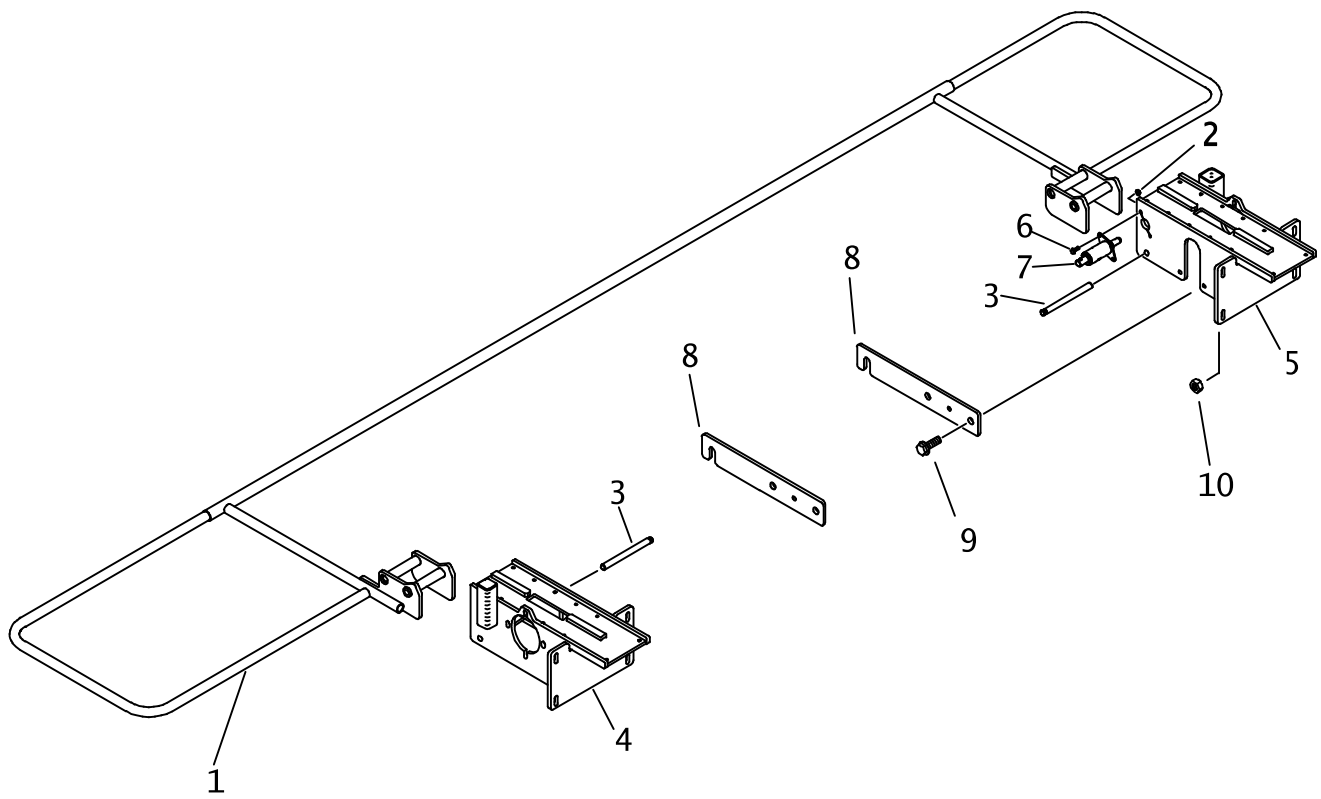

SHUTTLE GUARD

REF NO.	PART NUMBER	QTY	DESCRIPTION	REMARKS
1.	313-968	1	SHUTTLE GUARD	
2.	106-561	2	LOCKNUT (M8-1.25,PRV TRQ,10.9)	
3.	178-415	2	PIN	
4.	307-592	-	REAR SHUTTLE SUPPORT	
	327-1064	-	REAR SHUTTLE SUPPORT	SEE FOOTNOTE I
5.	307-591	-	FRONT SHUTTLE SUPPORT	
	327-1063	-	FRONT SHUTTLE SUPPORT	SEE FOOTNOTE I
6.	106-992	2	FLG LK SCREW (M8-1.25 X 25MM)	
7.	354-571	1	GUARD LOCK PIN	
8.	307-619	2	PIN RETAINER	
9.	106-632	4	FLG LK SCR (M12-1.75X35MM,SER)	
10.	106-685	4	LOCKNUT(M12-1.75,PRV TRQ,10.9)	

NOT SHOWN:

FOOTNOTES:

USE ON 4020 WITH RACK AND PINION

NOTE:

GUARD LOCK PIN

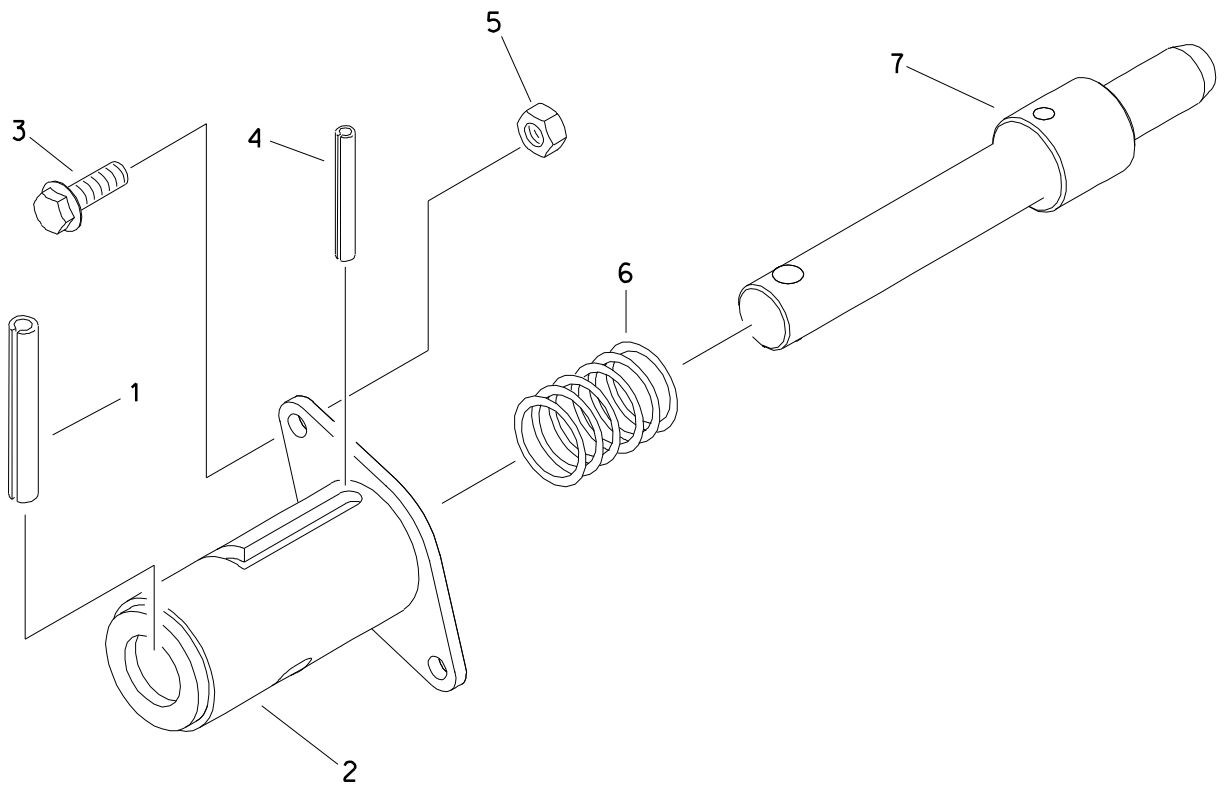

GUARD LOCK PIN

REF NO.	PART NUMBER	QTY	DESCRIPTION	REMARKS
	354-571		GUARD LOCK PIN	INCL REF NO.'S 1 THRU 7
1.	105-561	1	ROLL PIN (3/8" X 2-3/4")	
2.	354-566	1	PIN HOUSING	
3.	106-992	2	FLG LK SCREW (M8-1.25 X 25mm)	
4.	105-503	1	ROLL PIN (1/4" X 2")	
5.	106-561	2	LOCKNUT (M8-1.25, PRV TRQ, 10.9)	
6.	115-560	1	COMPRESSION SPRING	
7.	178-095	1	LOCKOUT PIN	

FOOTNOTES

FLUID SYSTEMS

MUD PUMP PLUMBING

120 GPM

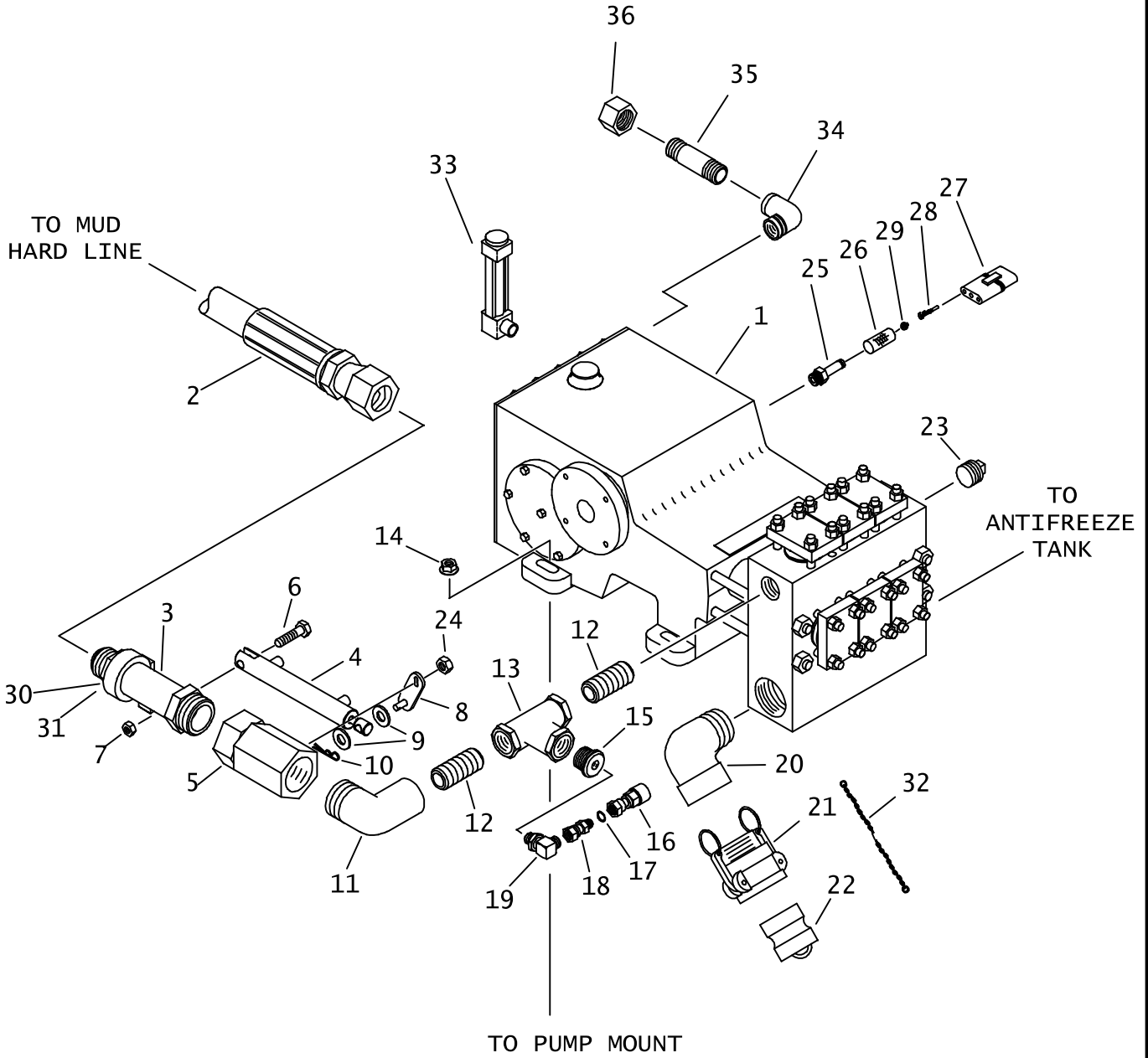

MUD PUMP PLUMBING

120 GPM

REF NO.	PART NUMBER	QTY	DESCRIPTION	REMARKS
1.	149-396	1	MUD PUMP	INCLUDES REF NO. 45
2.	153-390	1	HOSE (24JFX-240FX-38"-1250)	
3.	149-646	1	CYLINDER MOUNT (32N-24J)	
4.	151-211	1	CYL (1.25" X .50" X 4.00")	
5.	149-1001	1	SHUT-OFF (32NF-32NF)	
	191-069	-	BALL VALVE REPAIR KIT	
6.	106-334	1	SCREW (M12-1.75 X 50MM)	
7.	106-685	1	LOCKNUT(M12-1.75, PRV TRQ, 10.9)	
8.	306-388	1	VALVE ARM	
9.	106-391	2	WASHER (M12)	
10.	105-512	1	COTTER PIN (3/32" Xf")	
11.	115-052	1	ELBOW (32N-32NF90)	
12.	515-680	2	NIPPLE (32N-2")	
13.	153-344	1	TEE (32NF-32NF-32NF)3000PSI	
14.	106-442	4	FLG LOCKNUT (M16-2.00, PRV TRQ)	
15.	115-064	1	REDUCER (32N-12NF)	
16.	159-088	1	QDC BODY (08-08SF)	
17.	155-706	1	O-RING (908 D90)	
18.	156-732	1	CONNECTOR (08J-080)	
19.	154-490	1	CONNECTOR (12N-08090)	
20.	114-017	1	STREET ELBOW (48N-48NF90)	
21.	514-386	1	FHC BODY (3-1/2" FHC X 3"NPT)	
22.	153-255	1	FHC PLUG (-56)	
23.	156-938	1	PLUG (32N)	
24.	106-018	1	JAM NUT (3/8-NF)	
25.	216-047	1	SPEED PICKUP	
26.	216-026	1	FLEX-GUARD (.250")	
27.	215-224	1	3-WAY WP MALE CONNECTOR	
28.	214-104	3	PACKARD MALE TERMINAL	
29.	157-645	3	WEATHER-PAC SEAL (2.80MM)	
30.	178-969	AR	SHIM (.062)	REFER TO SERVICE BULLETIN 052-596 FOR INSTALLATION
31.	178-970	AR	SHIM (.100)	
32.	313-759	1	LANYARD	
33.	499-557	1	SIGHTGLASS	
34.	115-115	1	STREET ELBOW (08N-08NF90)	
35.	115-164	1	NIPPLE (08N-2")	
36.	514-106	1	CAP (08NF)	

NOT SHOWN:

FOOTNOTES:

NOTE:

1. REFER TO O-RING CHART (800-301) IN BACK OF THE BOOK FOR REPLACEMENT OF O-RINGS.

FLUID PUMP PLUMBING 70 GPM

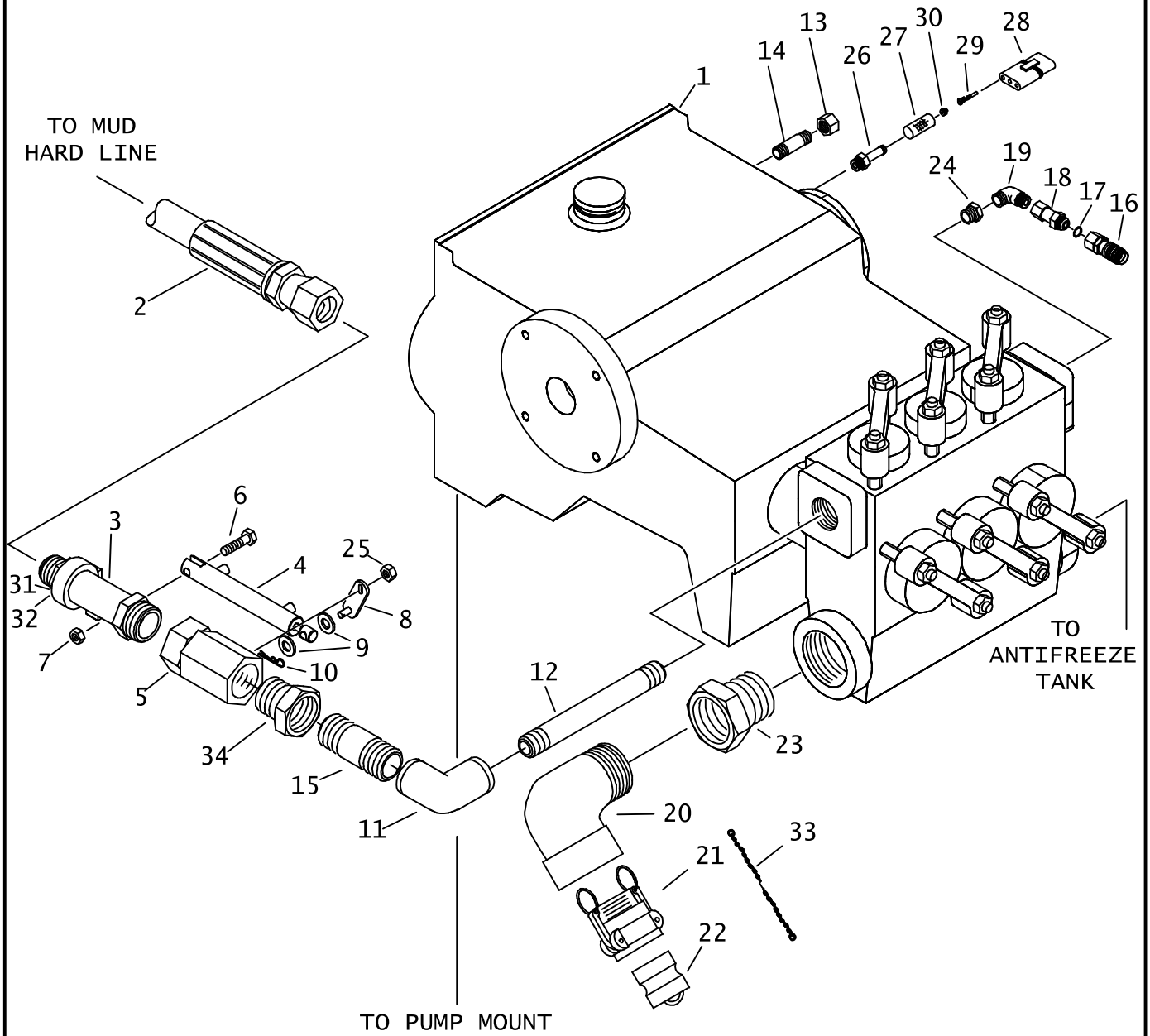

FLUID PUMP PLUMBING 70 GPM

REF NO.	PART NUMBER	QTY	DESCRIPTION	REMARKS
1.	158-434	1	FLUID PUMP	
2.	157-419	1	HOSE (24JFX-240FX-32"-1250)	
3.	149-646	1	CYLINDER MOUNT (32N-24J)	
4.	151-211	1	CYL (1.25" X .50" X 4.00")	
5.	149-076	1	SHUT-OFF (32NF-32NF)	
	191-069	-	BALL VALVE REPAIR KIT	
6.	106-334	1	SCREW (M12-1.75 X 50MM)	
7.	106-685	1	LOCKNUT(M12-1.75, PRV TRQ, 10.9)	
8.	306-388	1	VALVE ARM	
9.	106-391	2	WASHER (M12)	
10.	105-512	1	COTTER PIN (3/32" Xf")	
11.	515-679	1	ELBOW (20NF-20NF90)	
12.	157-418	1	NIPPLE (20N-8")	
13.	514-106	1	CAP (08NF)	
14.	115-161	1	NIPPLE (08N, 3-1/2")	
15.	115-207	1	NIPPLE (20N-2")	
16.	159-088	1	QDC BODY (08-08SF)	
17.	155-706	1	O-RING (908 D90)	
18.	156-732	1	CONNECTOR (08J-08O)	
19.	154-490	1	CONNECTOR (12N-08090)	
20.	114-004	1	STREET ELBOW (32N-32NF90)	
21.	159-485	1	FHC BODY (32-32N)	
22.	149-120	1	DUST PLUG (32 FHC)	
23.	114-024	1	REDUCER (40N-32NF)	
24.	155-208	1	REDUCER (20N-12NF)	
25.	106-018	1	JAM NUT (3/8-NF)	
26.	216-047	1	SPEED PICKUP	
27.	216-026	1	FLEX-GUARD (.250")	
28.	215-224	1	3-WAY WP MALE CONNECTOR	
29.	214-104	3	PACKARD MALE TERMINAL	
30.	157-645	3	WEATHER-PAC SEAL (2.80MM)	
31.	178-969	AR	SHIM (.062)	REFER TO SERVICE BULLETIN 052-596 FOR INSTALLATION
32.	178-970	AR	SHIM (.100)	REFER TO SERVICE BULLETIN 052-596 FOR INSTALLATION
33.	313-759	1	LANYARD	
34.	515-678	1	REDUCER (32N-20NF)	

NOT SHOWN:

FOOTNOTES:

NOTE:

1. REFER TO O-RING CHART (800-301) IN BACK OF THE BOOK FOR REPLACEMENT OF O-RINGS.

MUD SYSTEM PLUMBING

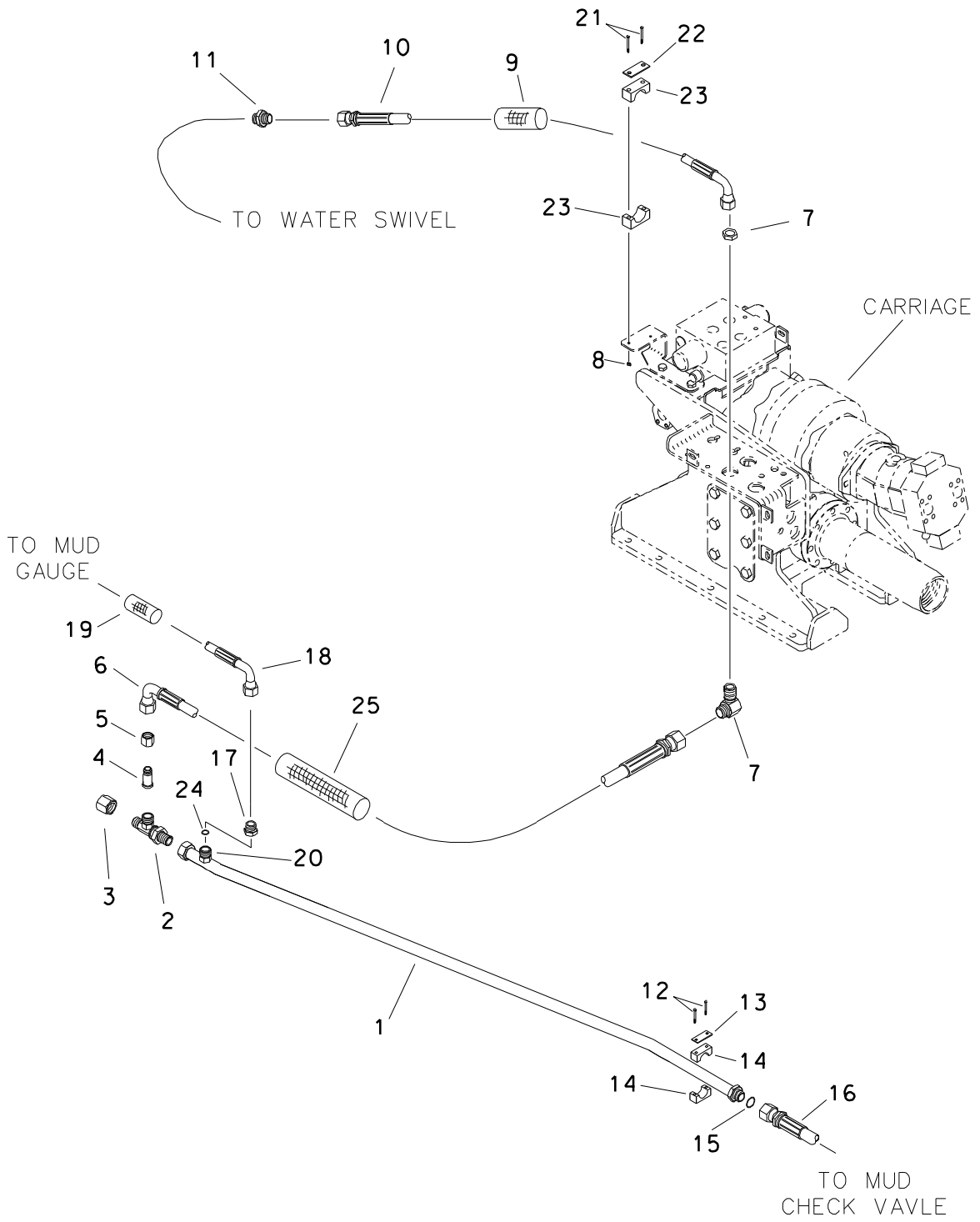

MUD SYSTEM PLUMBING

REF NO.	PART NUMBER	QTY	DESCRIPTION	REMARKS
1.	156-892	1	HYDRAULIC LINE (-24)	
2.	514-413	1	BK RUN TEE (240-240-240BK)	
3.	149-083	1	CAP (240F)	
4.	149-086	1	REDUCER NUT (240F)	
5.	149-085	1	REDUCER STEM (200)	
6.	153-745	1	HOSE (200FX90S-213"-3000)	
7.	153-679	1	SP CONNECTOR (200-20090BK)	
8.	106-237	2	LOCKNUT (M6-1.00,PRV TRQ,NLK)	
9.	117-568	1	ABRASION SLEEVE (2.38" X 66")	
10.	153-433	1	HOSE (200FX90L-66"-3000)	
11.	153-392	1	CONNECTOR (-24N-200)	
12.	105-224	2	BOLT (1/4-NC X 2-1/2")	
13.	322-362	1	BACKUP SPACER	
14.	111-008	1	BOLT-ON CLAMP (1-1/2", SET)	
15.	157-130	1	O-RING (029 D90)	
16.	153-390	-	HOSE (24JFX-240FX-38"-1250)	120 GPM
	157-419	-	HOSE (24JFX-240FX-32"-1250)	70 GPM
17.	154-373	1	REDUCER (040-060F)	
18.	515-137	1	HOSE (040FX90-90"-3000)	
19.	117-209	1	ABRASION SLEEVE (1.00" X 90")	
20.	157-038	1	O-RING (012 D90)	
21.	107-151	2	SCREW (M6-1.00 X 85MM)	
22.	110-973	1	COVER PLATE	
23.	110-970	1	CLAMP (2.00") PAIR	
24.	157-038	1	O-RING (012 D90)	
25.	117-705	1	ABRASION SLEEVE (2.38" X 78")	

FOOTNOTES

FLUID PUMP (FLUID END)

120 GPM

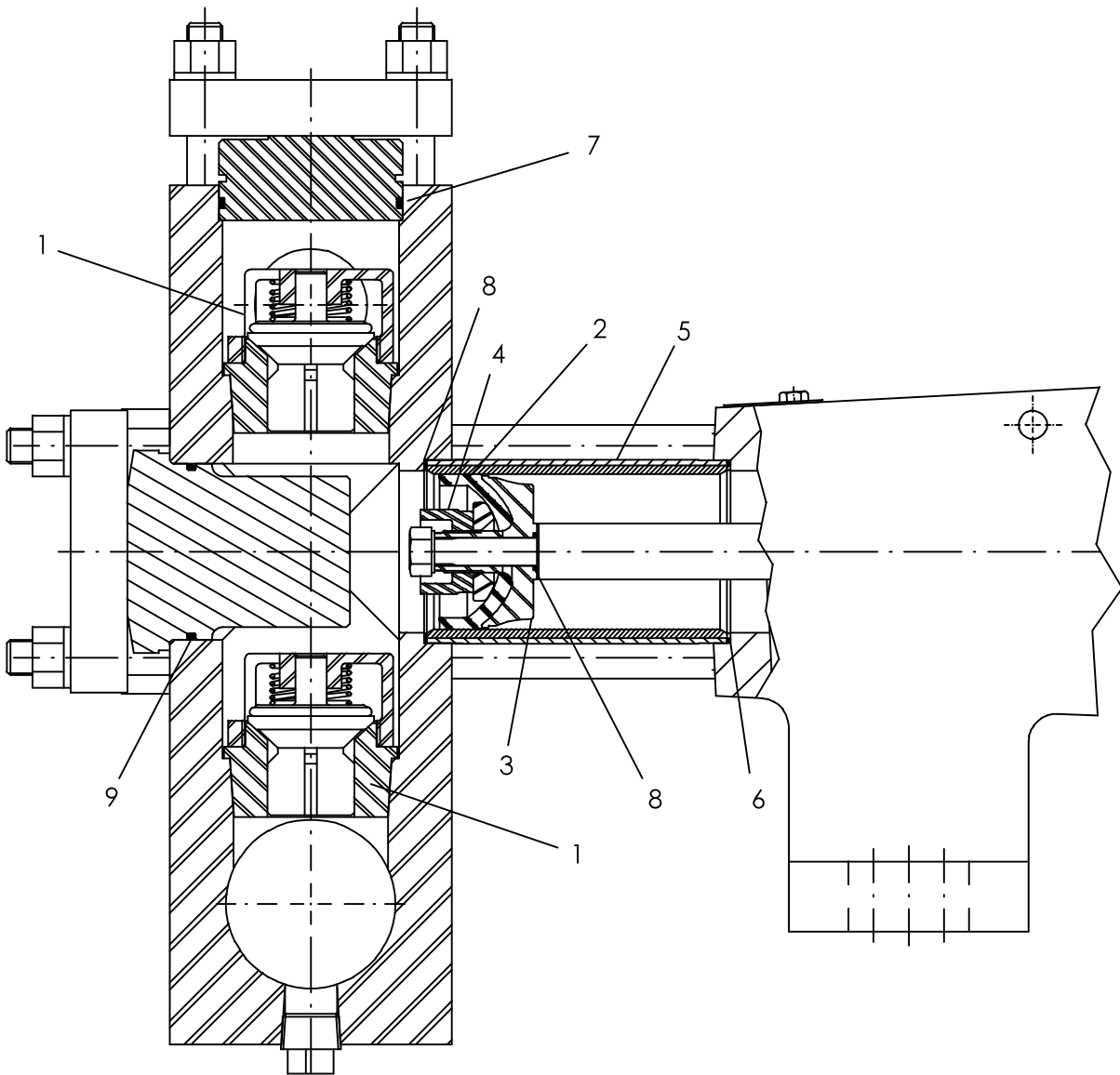

FLUID PUMP (FLUID END) 120 GPM

REF NO.	PART NUMBER	QTY	DESCRIPTION	REMARKS
1.	191-054	1	VALVE REPAIR KIT	INCLUDES PARTS FOR ALL VALVES IN PUMP. SEE FOOTNOTE 1.
2.	191-1008	1	PACKING REPAIR KIT	
3.	499-041	3	CUP HOLDER	
4.	499-039	3	PLUNGER NUT	
5.	499-089	3	CYL (2.750")	
6.	499-042	3	CYLINDER GASKET	
7.	157-191	3	O-RING (233 D90)	
8.	157-202	3	O-RING (042 D70)	
9.	157-031	3	O-RING (234 D90)	

NOT SHOWN:

FOOTNOTES:

KIT INCLUDES ALL PARTS, O-RINGS, GASKETS AND PLUNGER NUTS TO REBUILD ALL CYLINDERS.

NOTE:

FLUID PUMP (FLUID END)

70 GPM

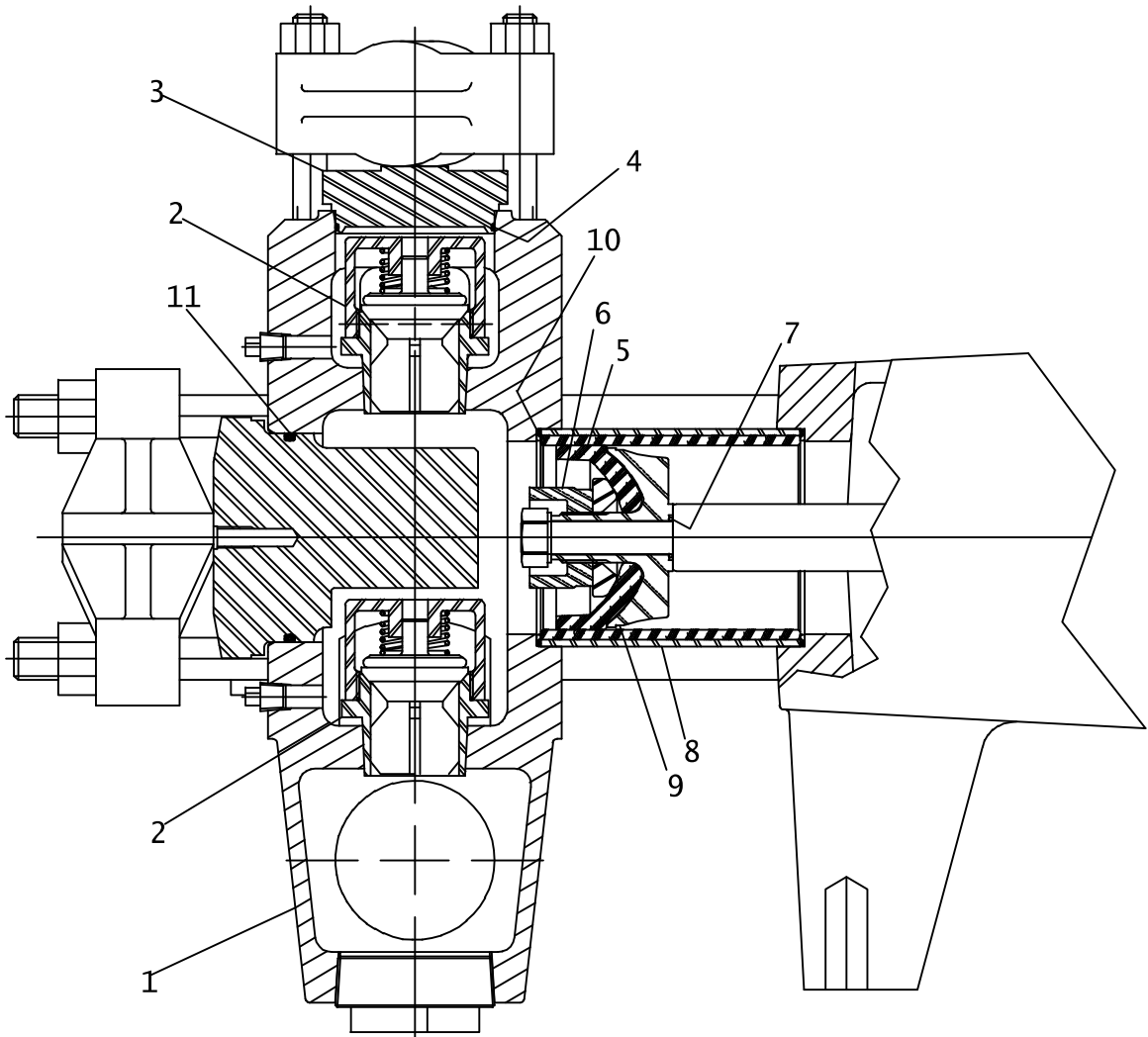

FLUID PUMP (FLUID END) 70 GPM

REF NO.	PART NUMBER	QTY	DESCRIPTION	REMARKS
	158-434		FLUID PUMP	INCL REF NO'S 1 - 11
	197-062		REBUILT 158-434 MUD PUMP	INCL REF NO'S 1 - 11
	158-017		MUD PUMP	
	190-783		L1122 A/R VALVE SERVICE KIT	INCL REF NO'S 2, 4 & 11
1.	499-035	1	FLUID CYLINDER	
2.	499-036	6	VALVE	
3.	499-037	3	VALVE COVER	
4.	157-190	3	O-RING (139 D90)	
5.	191-1008	1	PACKING REPAIR KIT	SEE FOOTNOTE 1
6.	499-039	3	PLUNGER NUT	
7.	155-778	3	O-RING (014 D70, VITON)	
8.	499-040	3	CYLINDER (2-3/4")	
9.	499-041	3	CUP HOLDER	
10.	499-042	6	CYLINDER GASKET	
11.	157-191	3	O-RING (233 D90)	

NOT SHOWN:

FOOTNOTES:

KIT INCLUDES ALL PARTS, O-RINGS, GASKETS AND PLUNGER NUTS TO REBUILD ALL CYLINDERS

NOTE:

FLUID PUMP (POWER END)

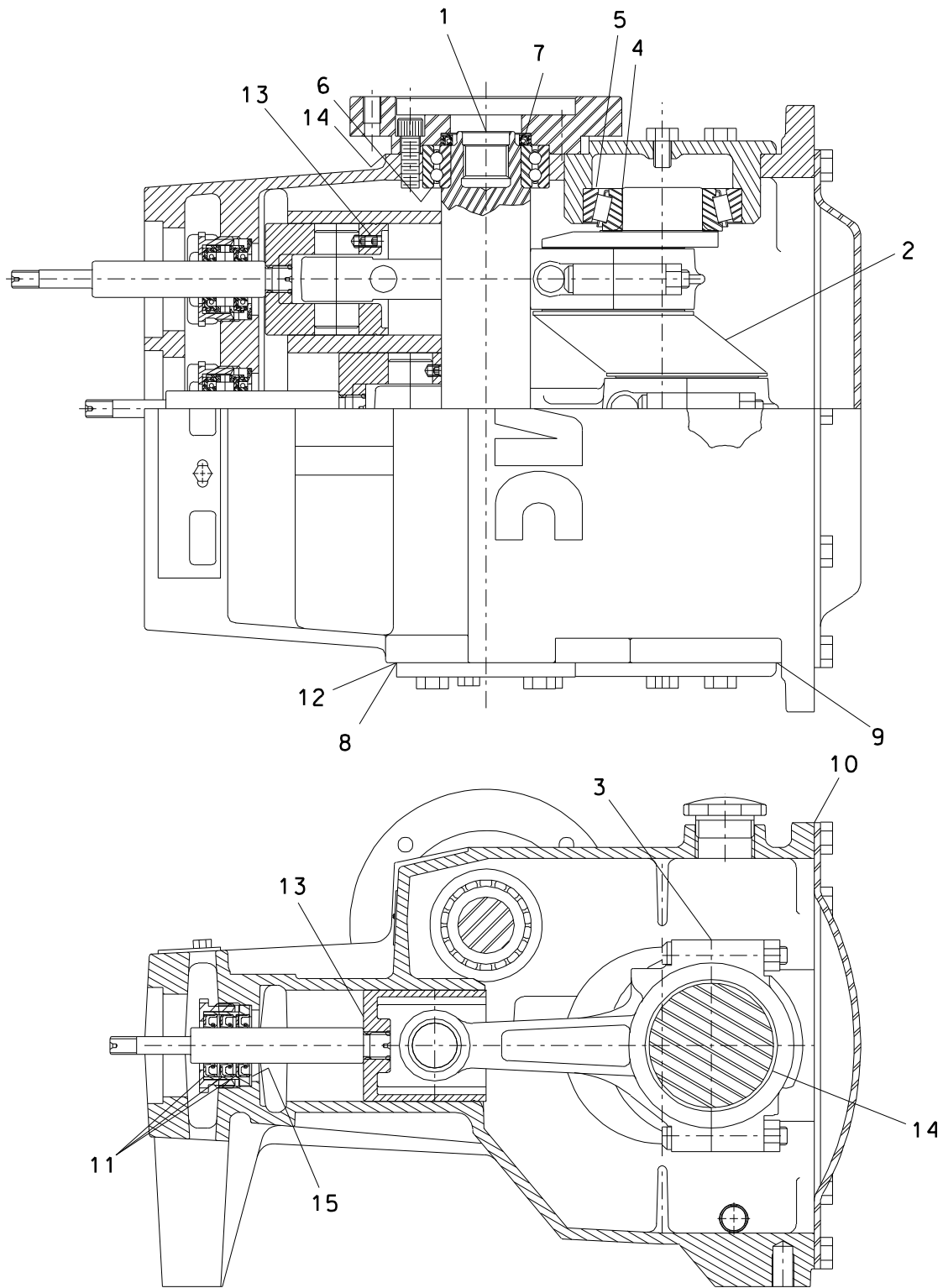

FLUID PUMP (POWER END)

REF NO.	PART NUMBER	QTY	DESCRIPTION	REMARKS
	158-434		FLUID PUMP	INCL REF NO'S 1 - 15
	197-062		REBUILT 158-434 FLUID PUMP	
	158-017		FLUID PUMP	INCL REF NO'S 1 - 15
1.	499-075	1	PINION SHAFT	
2.	499-076	1	ECCENTRIC GEAR	
3.	499-077	3	CONNECTING ROD	
4.	126-192	2	TAPERED BEARING (2.250")	
5.	126-193	2	TAPERED RACE (4.437")	
6.	125-144	2	BALL BEARING (1.968")	
7.	157-738	1	OIL SEAL, PINION SHAFT	
8.	165-884	2	GASKET, PINION CAP	
9.	165-885	2	GASKET, BEARING CAP	
10.	165-886	1	GASKET, BACKCOVER	
11.	157-739		INTERNAL SEAL (.....")	
12.	165-887	6	SHIM	
13.	499-078	3	CROSSHEAD	
14.	126-194	6	ROD BEARING (PAIR)	
15.	165-888	3	SEAL HOLDER - GASKET	

FOOTNOTES

PUMP MOUNT

70GPM & 120GPM FLUID PUMPS

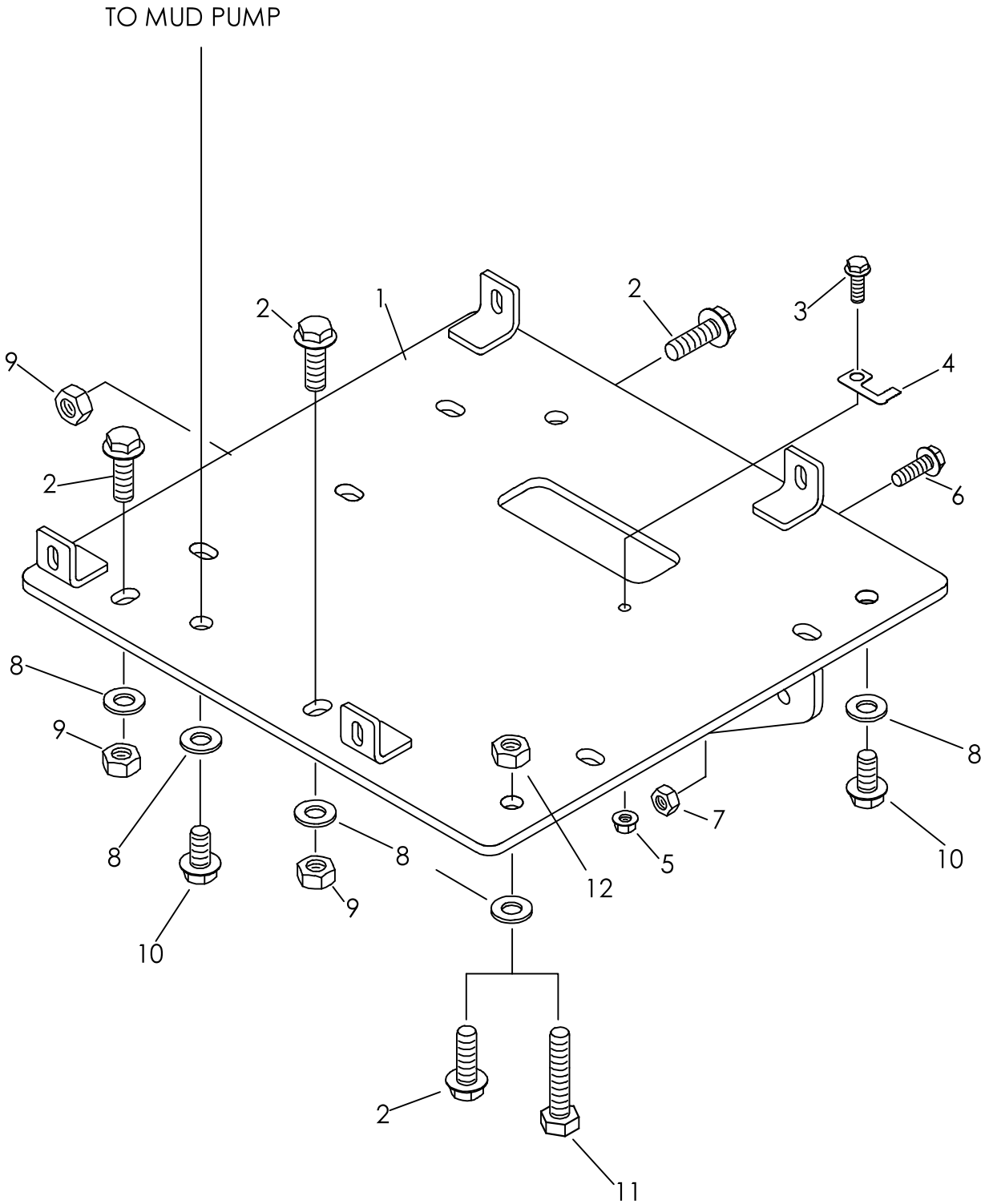

PUMP MOUNT

70GPM & 120GPM FLUID PUMPS

REF NO.	PART NUMBER	QTY	DESCRIPTION	REMARKS
1.	319-544	1	PUMP MOUNT	USED WITH 70 GPM & 120 GPM PUMPS
2.	106-470	AR	FLG SCREW (M16-2.00 X 40MM)	USE 4 W/70 GPM & 3 W/120 GPM PUMPS
3.	106-381	1	FLG LK SCREW (M8-1.25 X 25MM)	USED WITH 70 GPM & 120 GPM PUMPS
4.	211-041	1	CONNECTOR CLIP	USED WITH 70 GPM & 120 GPM PUMPS
5.	106-386	1	FLG LOCKNUT (M8-1.25)	USED WITH 70 GPM & 120 GPM PUMPS
6.	106-632	1	FLG LK SCR (M12-1.75X35MM,SER)	USED WITH 70 GPM & 120 GPM PUMPS
7.	106-685	1	LOCKNUT(M12-1.75,PRV TRQ,10.9)	USED WITH 70 GPM & 120 GPM PUMPS
8.	106-398	8	WASHER (M16, HARDENED)	USED WITH 70 GPM PUMP
	105-398	6	WASHER (1/2")	USED WITH 120 GPM PUMP
9.	106-545	3	LOCKNUT (M16-2.0,PRV TRQ,10.9)	USED WITH 70 GPM & 120 GPM PUMPS
10.	105-400	5	BOLT (5/8-NC X 1-1/4")	USED WITH 70 GPM PUMP
	106-341	3	SCREW (M16-2.0 X 70MM)	USED WITH 120 GPM PUMP
11.	108-100	1	SCREW (M16-2 X 80MM, 10.9)	USED WITH 120 GPM PUMP
12.	106-545	1	LOCKNUT (M16-2.0,PRV TRQ,10.9)	USED WITH 70 GPM PUMP

NOT SHOWN:

FOOTNOTES:

NOTE:

FLUID PUMP (POWER END)

L1122, L1622

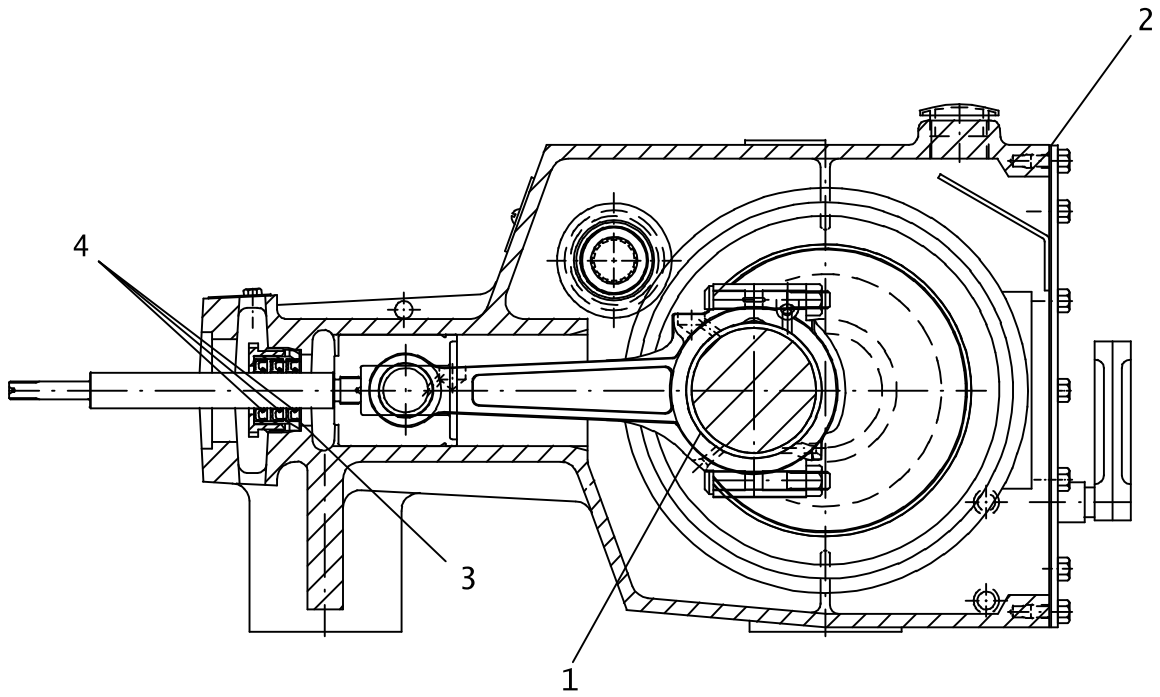
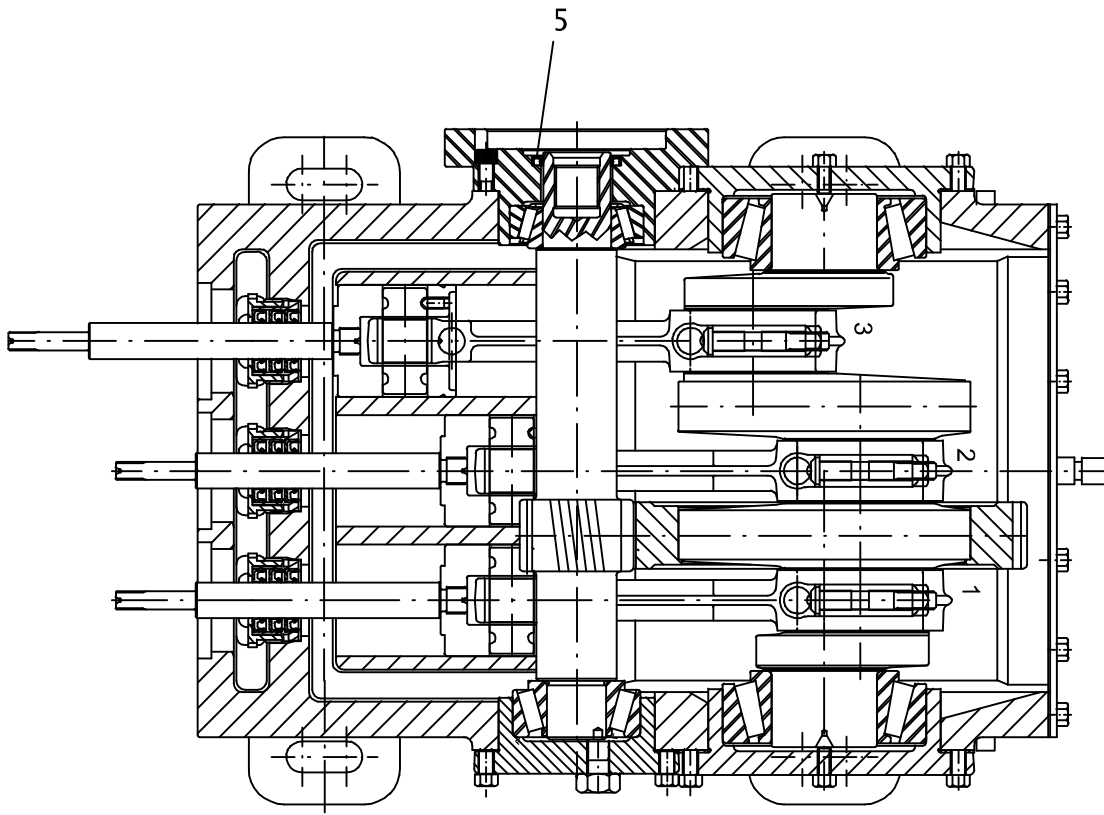

FLUID PUMP (POWER END)

L1122, L1622

REF NO.	PART NUMBER	QTY	DESCRIPTION	REMARKS
1.	126-194	3	ROD BEARING (PAIR)	CONNECTING ROD USE 3 PAIR PER PUMP
2.	165-896	1	BACK COVER GASKET	
3.	165-888	3	SEAL HOLDER GASKET	
4.	157-739	9	INTERNAL SEAL	PLUNGER ROD
5.	157-742	1	INTERNAL SEAL	ADAPTER

NOT SHOWN:

FOOTNOTES:

NOTE:

ANTIFREEZE TANK

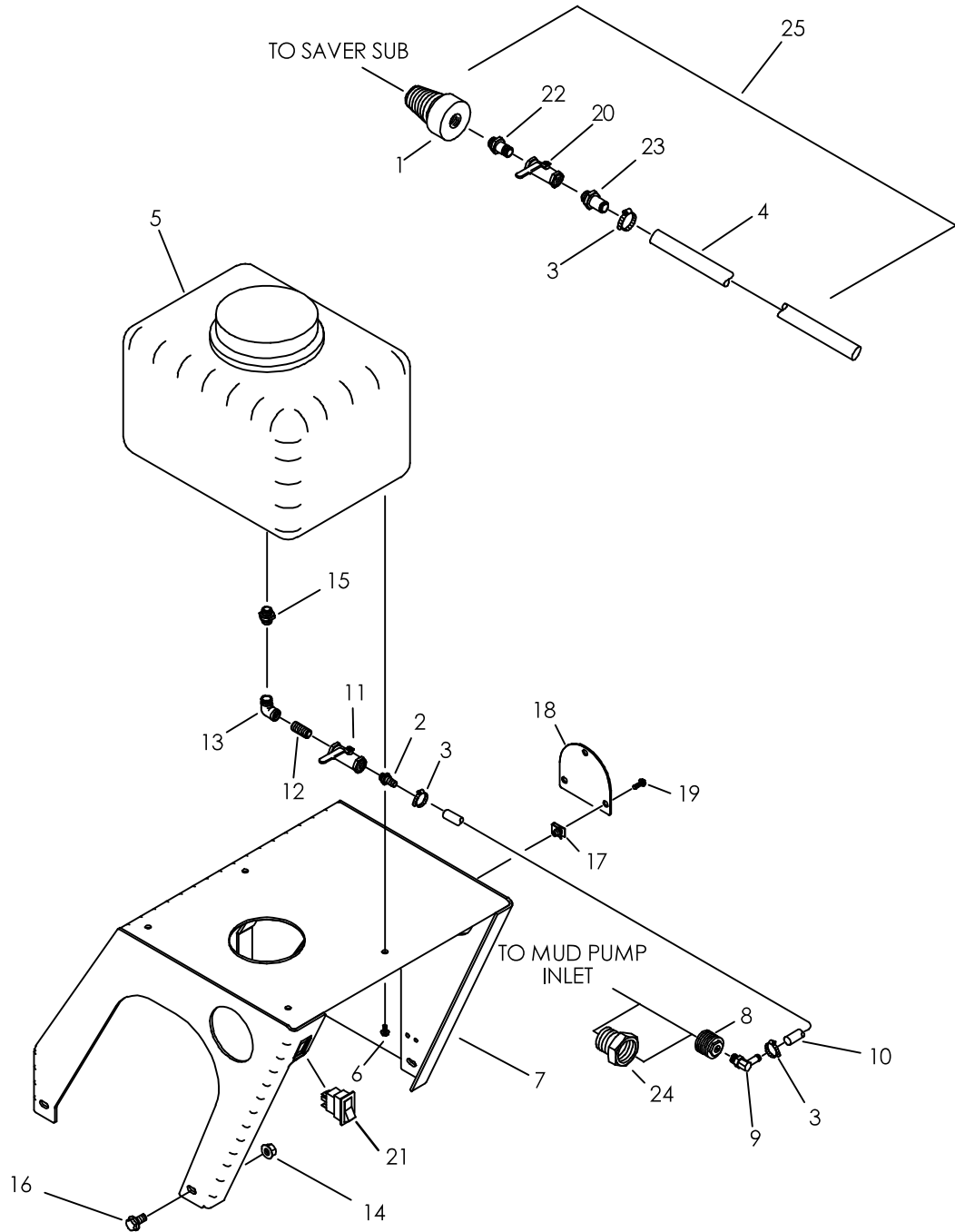

ANTIFREEZE TANK

REF NO.	PART NUMBER	QTY	DESCRIPTION	REMARKS
1.	211-097	1	ADAPTER	USE WITH AT PIPE IOD = 4.125" USE WITH JTMI PIPE IOD = 3.50"
	194-244	1	ADAPTER	
2.	155-136	1	S/O COUPLER (16N-16H)	
3.	110-353	3	WORM CLAMP (3/4" TO 1-1/2")	
4.	116-897	AR	BULK TUBING (1", SOLD PER 1')	USE I @ 72"
5.	364-515	1	WATER TANK (8 GAL)	
	190-053	-	POLY-PATCH TANK REPAIR KIT	
	110-707		TANK CAP (96NF)	
6.	105-836	4	FLG LOCK BOLT (1/4-NC X 1/2")	
7.	319-546	1	TANK MOUNT	
8.	115-085	1	REDUCER (32N-16NF)	SEE FOOTNOTE 1
	153-335	1	REDUCER BUSHING (48N-16NF)	SEE FOOTNOTE 2
9.	155-137	1	S/O COUPLER(16N-16H90)	
10.	116-460	AR	BULK HOSE (1", SOLD PER 1')	USE I @ 20" FOR 70 GPM PUMP
	116-460	AR	BULK HOSE (1", SOLD PER 1')	USE I @ 22" FOR 70 GPM PUMP
11.	514-318	1	SHUT-OFF (16NF-16NF)	ROTATE HANDLE TO SIDE, POINTED DOWN.
12.	114-011	1	ALL THREAD (16N)	
13.	115-440	1	STREET ELBOW (16N-16NF90)	
14.	106-387	4	FLG LOCKNUT (M10-1.50)	
15.	514-400	1	BK CONN (16NF-16NFBK, NYL)	
16.	106-164	4	FLG LK SCREW (M10-1.50 X 30MM)	
17.	106-551	3	CLIP NUT (M8-1.25)	
18.	310-694	1	COVER	
19.	106-991	3	FLG LK SCREW (M8-1.25 X 20MM)	
20.	120-074	1	SHUT-OFF VALVE (16S-16S)	
21.	217-907	1	ROCKER SWITCH (DPDT) ON-ON	
22.	514-121	1	CONNECTOR (16N-16S)	
23.	514-088	1	S/O COUPLER (16S-16H)	
24.	114-024	1	REDUCER (40N-32NF)	SEE FOOTNOTE 1
25.	101-134	1	ANTI-FREEZE RECLAIMER	USE W/ AT PIPE; INCLUDES REF. #'S 1, 3, 4, 20, 22, 23
	101-137	1	ANTI-FREEZE RECLAIMER	USE W/ JT PIPE; INCLUDES REF. #'S 1, 3, 4, 20, 22, 23

NOT SHOWN:

153-255 FHC PLUG (I-56) USE TO PLUG FHC FEMALE INLET ON MUD PUMP.

FOOTNOTES:

1. USED WITH I58-434 (70 GPM MUD PUMP)
2. USED WITH I49-396 (120 GPM MUD PUMP)

NOTE:

REFER TO O-RING CHART (800-30I) IN BACK OF THE BOOK FOR REPLACEMENT OF O-RINGS.

WASH WAND

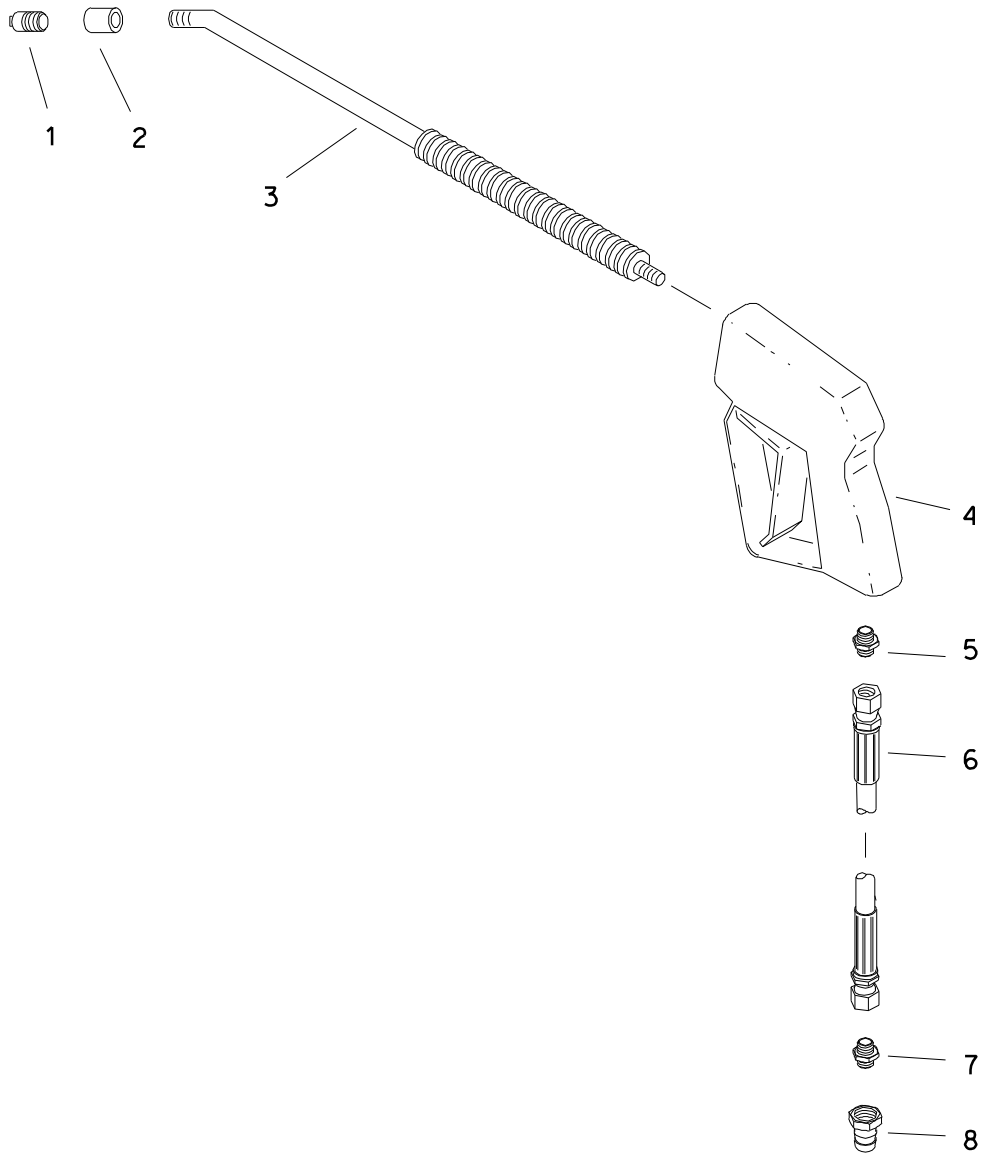

WASH WAND

REF NO.	PART NUMBER	QTY	DESCRIPTION	REMARKS
1.	155-242	1	NOZZLE (04N, ORF .047", TC)	
2.	115-170	1	COLLAR (04NF)	
3.	259-353	1	WASH WAND (04N-36")	
4.	259-197	1	SPRAY GUN	
	190-179		SEAL REPAIR KIT	RHINO INDUSTRIES (190-938 CHAPPELL SUPPLY)
5.	514-141	1	CONNECTOR (06N-080)	
6.	154-753	1	HOSE (08OFX-600"-3000)	
7.	154-233	1	CONNECTOR (08S-080)	
8.	159-089	1	QDC ADAPTER (08-08SF)	
	190-186		SEAL REPAIR KIT	

FOOTNOTES

NOTE

REFER TO O-RING CHART (800-301) IN BACK OF THE BOOK FOR REPLACEMENT OF O-RINGS.

HYDRAULICS

HYDRAULIC SCHEMATIC JT4020 ALL TERRAIN

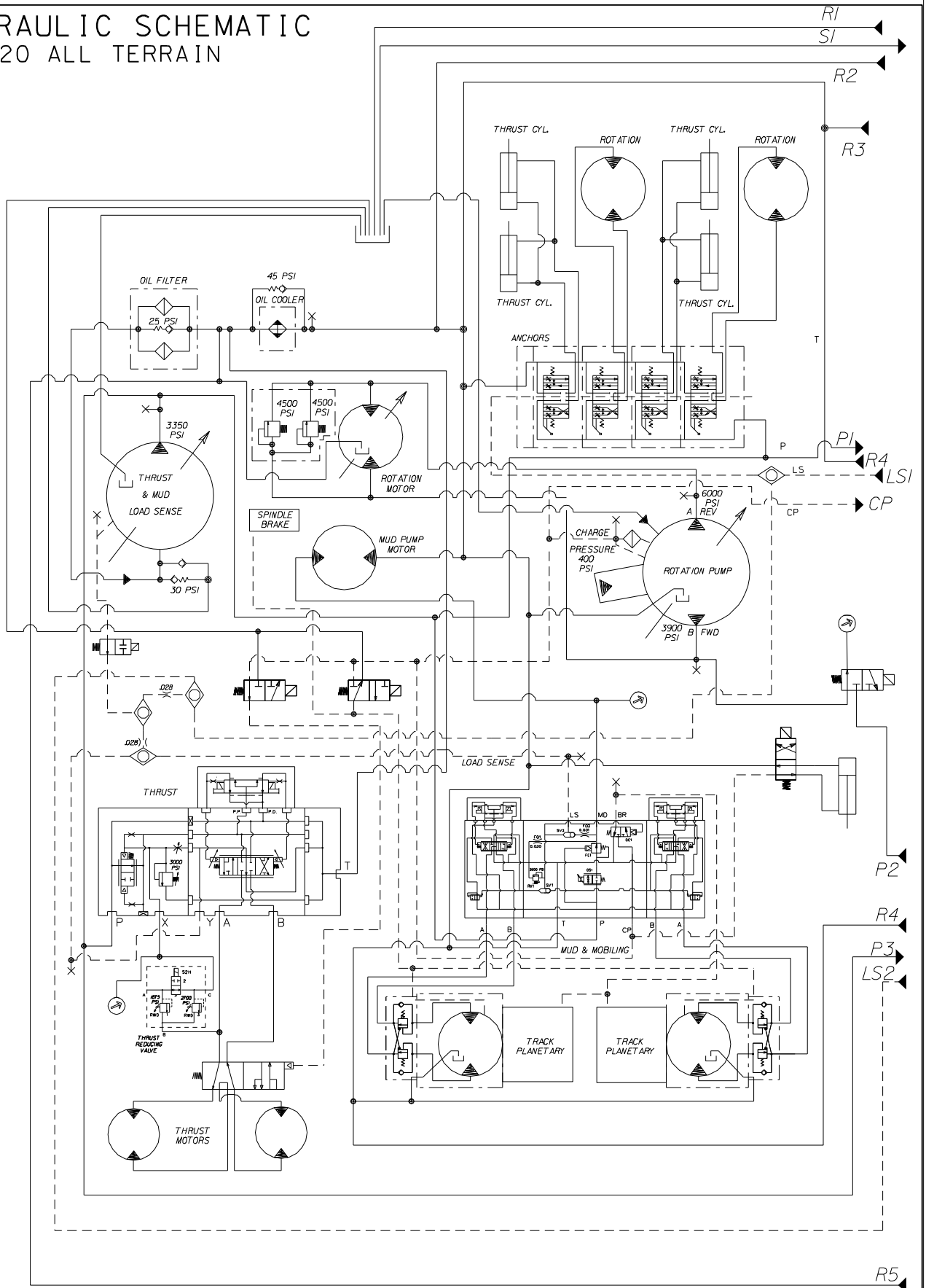

HYDRAULIC SCHEMATIC JT4020 ALL TERRAIN

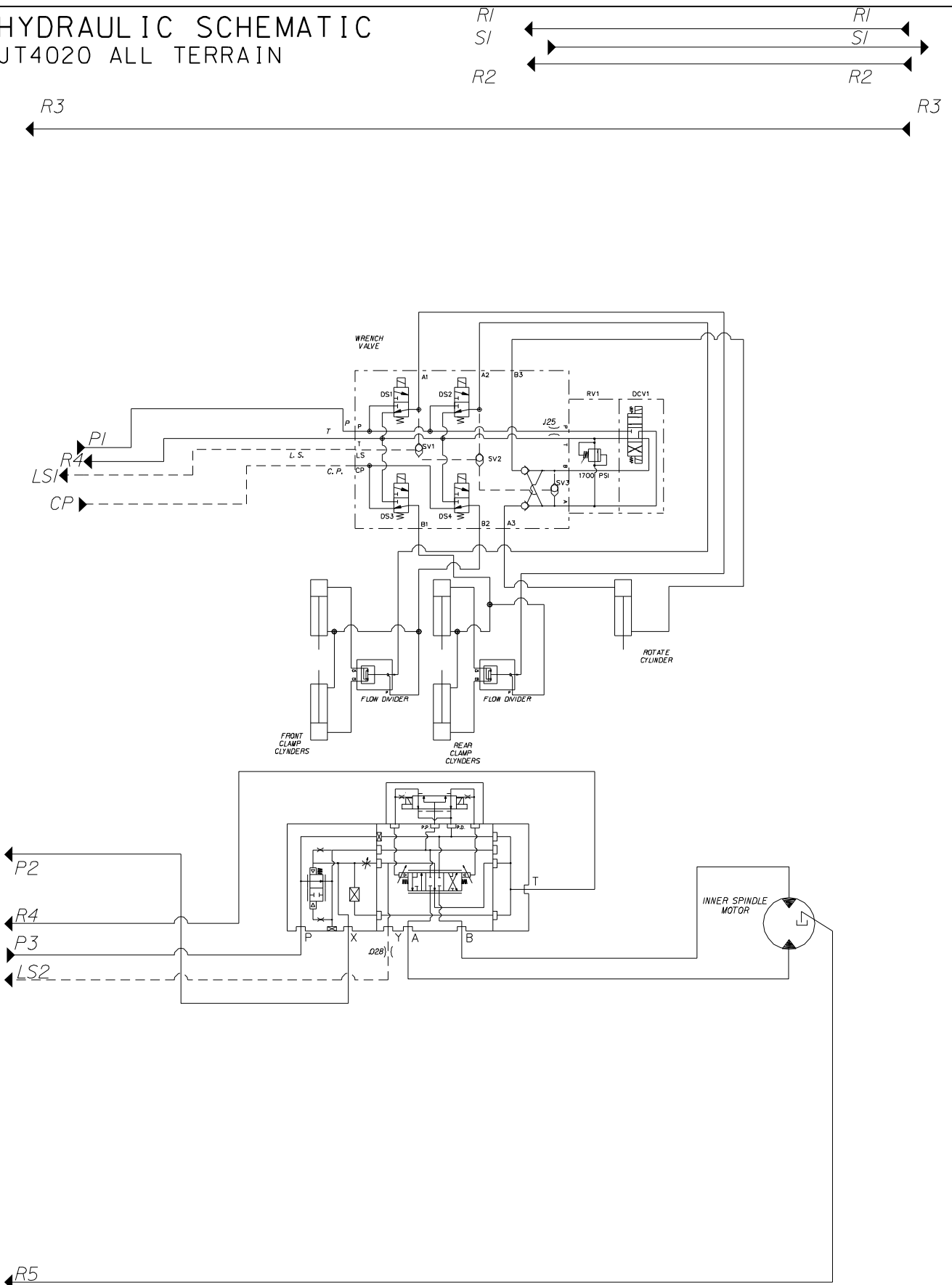

HYDRAULIC SCHEMATIC JT4020 ALL TERRAIN

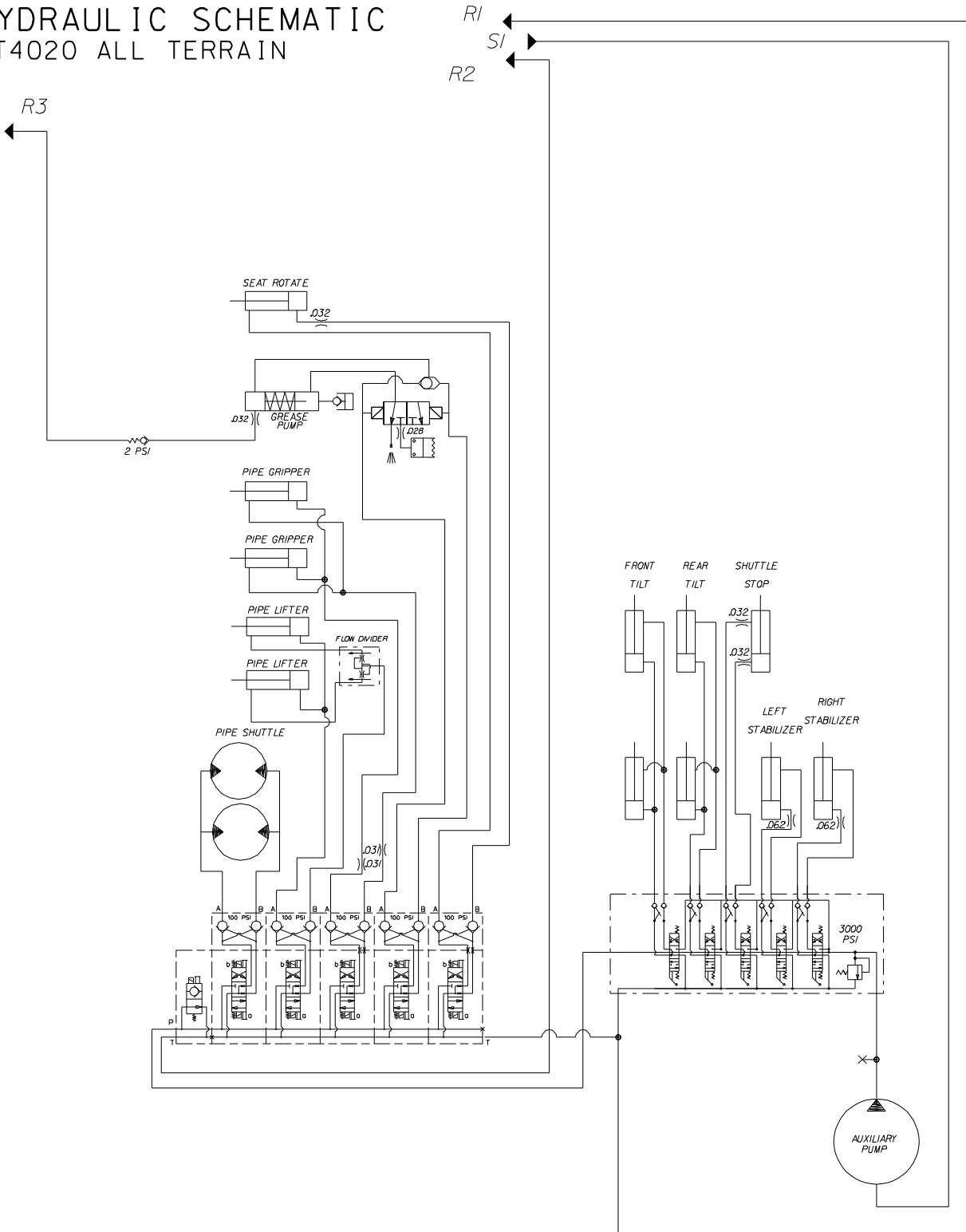

HYDRAULIC DIAGRAM

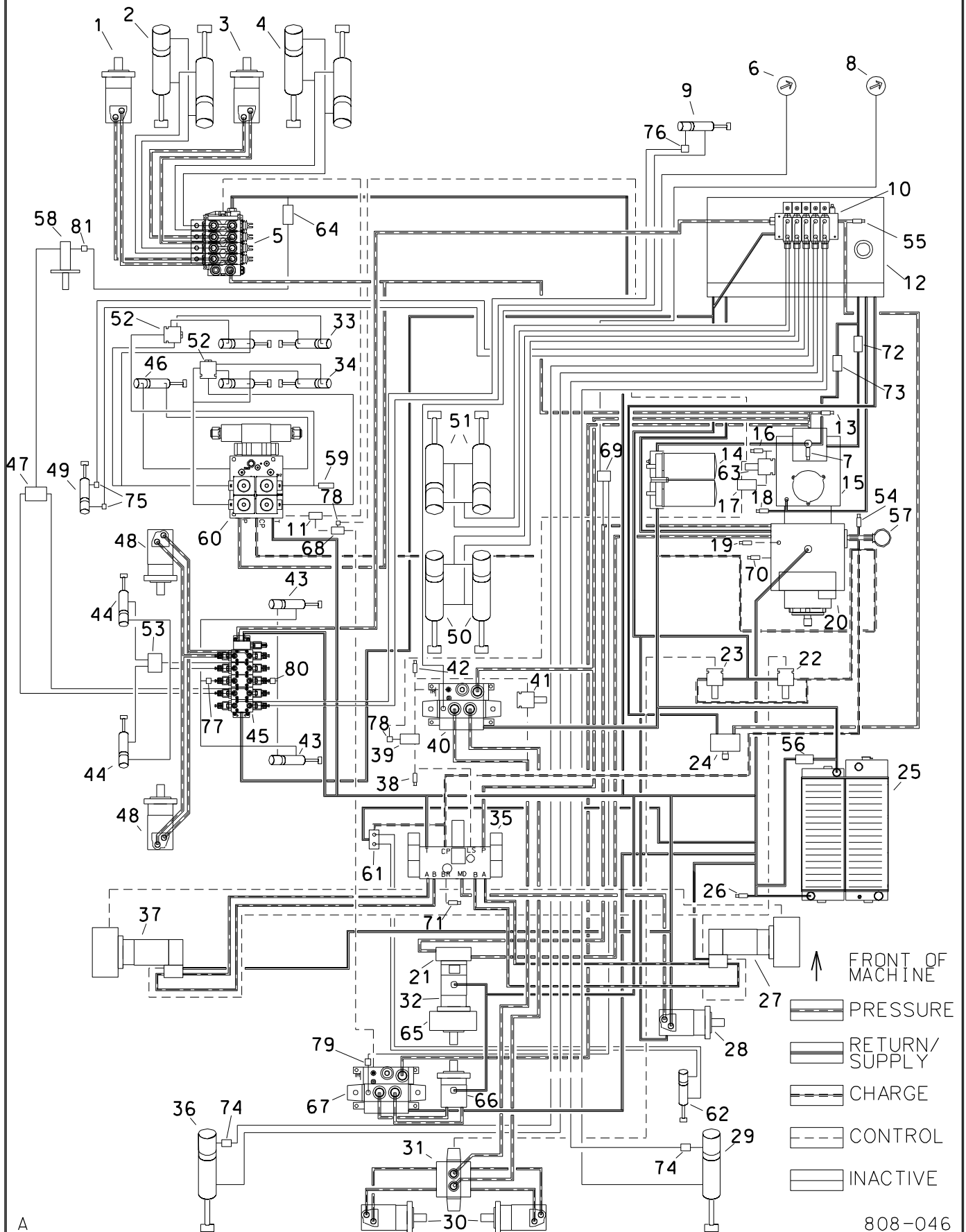

HYDRAULIC DIAGRAM

REF NO.	DESCRIPTION	REMARKS
1.	LEFT ANCHOR MOTOR	
2.	LEFT ANCHOR CYLINDERS	
3.	RIGHT ANCHOR MOTOR	
4.	RIGHT ANCHOR CYLINDERS	
5.	ANCHOR VALVE	
6.	THRUST PRESSURE GAUGE	
7.	TEST PORT	LOAD SENSE PUMP INLET PRESSURE
8.	ROTATION PRESSURE GAUGE	
9.	SEAT ROTATION CYLINDER	
10.	SETUP VALVE	
11.	SHUTTLE VALVE	
12.	HYDRAULIC RESERVOIR	
13.	TEST PORT	LOAD SENSE PUMP OUTLET PRESSURE
14.	OIL FILTERS	RETURN
15.	HYDRAULIC PUMP	THRUST, FLUID, ANCHORS, WRENCHES, INNER ROT., GR. DRIVE
16.	TEST PORT	LOAD SENSE SIGNAL PRESSURE
17.	SHUTTLE VALVE	
18.	TEST PORT	LOAD SENSE PUMP CASE PRESSURE
19.	TEST PORT	FORWARD ROTATION
20.	HYDROSTATIC PUMP	
21.	SPIKE RELIEF MANIFOLD	
22.	TWO SPEED MOBILING VALVE	
23.	TWO SPEED THRUST VALVE	
24.	AUXILIARY PUMP	
25.	OIL COOLER/RADIATOR	
26.	TEST PORT	PRE-COOLER PRESSURE
27.	GROUND DRIVE MOTOR W/ COUNTERBALANCE VALVE	RIGHT
28.	DRILLING FLUID MOTOR	
29.	RIGHT STABILIZER CYL	
30.	THRUST MOTORS	
31.	SERIES PARALLEL VALVE	
32.	ROTATION MOTOR	
33.	FRONT WRENCH CYLINDER	
34.	REAR WRENCH CYLINDER	
35.	GROUND DRIVE AND DRILLING FLUID VALVE	
36.	LEFT STABILIZER CYL	
37.	GROUND DRIVE MOTOR W/ COUNTERBALANCE VALVE	LEFT
38.	TEST PORT	LOAD SENSE SIGNAL (GROUND DRIVE/FLUID)
39.	SHUTTLE VALVE	

HYDRAULIC DIAGRAM

REF NO.	DESCRIPTION	REMARKS
40.	THRUST VALVE	
41.	THRUST LIMITER VALVE	
42.	TEST PORT	LOAD SENSE SIGNAL (THRUST)
43.	PIPE GRIPPER CYL	
44.	PIPE LIFTER CYL	
45.	PIPE HANDLING VALVE	
46.	WRENCH ROTATE CYLINDER	
47.	SELECTOR VALVE	GREASER
48.	SHUTTLE MOTOR	
49.	SHUTTLE STOP CYLINDER	
50.	REAR DRILL FRAME PIVOT CYL	
51.	FRONT DRILL FRAME PIVOT CYL	
52.	FLOW DIVIDER/PO CHECK VALVE	
53.	FLOW DIVIDER VALVE	
54.	TEST PORT	CHARGE PRESSURE
55.	TEST PORT	AUXILIARY CIRCUIT
56.	BYPASS CHECK VALVE	
57.	HYDRAULIC OIL FILTER	CHARGE
58.	GREASE PUMP	
59.	PRESSURE SWITCH	
60.	WRENCH VALVE	
61.	MUD SHUT-OFF VALVE	
62.	MUD SHUT-OFF CYLINDER	
63.	LOAD SENSE SHUT-OFF	
64.	CHECK VALVE	
65.	SPINDLE BRAKE	
66.	INNER ROTATION MOTOR	
67.	INNER ROTATION VALVE	
68.	SHUTTLE VALVE	
69.	HYDRAULIC VALVE	INNER/OUTER ROTATION PRESSURE
70.	TEST PORT	REVERSE ROTATION
71.	TEST PORT	BRAKE RELEASE PRESSURE
72.	BYPASS CHECK VALVE	
73.	BYPASS CHECK VALVE	
74.	ORIFICE FITTING	
75.	ORIFICE FITTING	
76.	ORIFICE FITTING	
77.	ORIFICE FITTING	
78.	ORIFICE FITTING	
79.	ORIFICE FITTING	
80.	ORIFICE FITTING	
81.	ORIFICE FITTING	

OIL COOLER HYDRAULICS

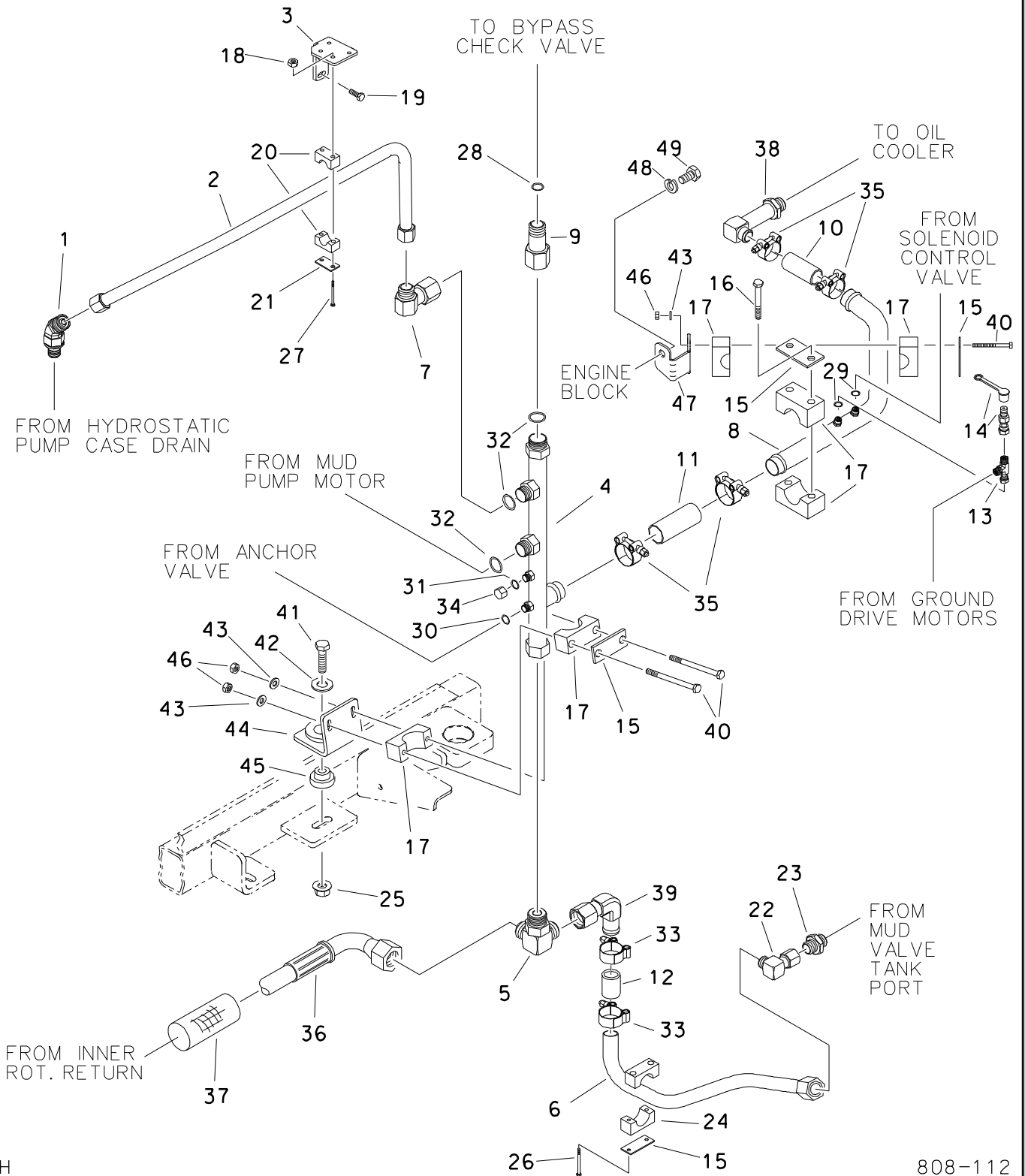

OIL COOLER HYDRAULICS

REF NO.	PART NUMBER	QTY	DESCRIPTION	REMARKS
1.	154-371	1	CONNECTOR (12S-16045)	
2.	156-177	1	HYD LINE (-16)	CASE DRAIN
3.	354-464	1	TOP REAR COOLANT BRACKET	
4.	153-389	1	COOLER BY-PASS	COOLER TUBE
5.	157-261	1	SPECIAL TEE (16S-200-200)	
6.	157-251	1	HYD LINE (20)	VALVE DRAIN
7.	154-290	1	UNION (16Q-16QFX90)	
8.	157-243	1	COOLER SUPPLY TUBE	COOLER TUBE
9.	510-014	1	UNION (16J-16QFX)	
10.	117-897	AR	BULK HOSE (1-1/2", SOLD PER 1")	USE 1 @ 14.5"
11.	117-897	AR	BULK HOSE (1-1/2", SOLD PER 1")	USE 1 @ 4.75"
12.	117-896	AR	BULK HOSE (1-1/4", SOLD PER 1")	USE 1 @ 8.50"
13.	154-265	1	UN RUN TEE (04QFX-04Q-04Q)	
14.	159-156	1	QDC ADAPTER (Q2-04QF)	
	159-148	1	DUST CAP (1/8")	
15.	322-362	3	BACKUP SPACER	
16.	105-224	2	BOLT (1/4-NC X 2-1/2")	
17.	111-008	2	BOLT-ON CLAMP (1-1/2", SET)	
18.	105-085	2	LOCKNUT (1/4-NC)	
19.	105-245	2	SCREW (M10-1.50 X 25mm)	
20.	110-573	1	BOLT-ON CLAMP (1", SOLD PER SET)	
21.	322-289	1	BACKUP (BOLT-ON)	
22.	514-422	1	CONNECTOR (20Q-20QFX90)	
23.	514-094	1	CONNECTOR (16S-20Q)	
24.	110-852	1	BLT-ON CLP (1.2", SOLD PER SET)	
25.	105-833	1	FLG LOCKNUT (1/2-NC)	
26.	105-224	2	BOLT (1/4-NC X 2-1/2")	
27.	107-215	2	FLG LK BLT (1/4-NC X 2-1/4")	
28.	155-748	1	O-RING (916 D90)	
29.	157-037	2	O-RING (011 D90)	
30.	157-040	1	O-RING (016 D90)	
31.	157-039	1	O-RING (014 D90)	
32.	155-714	3	O-RING (Q21 D90)	
33.	111-028	2	T-BOLT CLAMP (1.75"-2.00")	
34.	154-327	1	CAP (08QF)	
35.	318-890	4	T-BLT CLP BRIDG 1.875 - 2.188	
36.	153-751	1	HOSE (20QFX90S-88"-3000)	SEE FOOTNOTE 1, AT ONLY
	514-177	-	CAP (20QF)	JT ONLY
37.	117-567	1	ABRASION SLEEVE (2.38" X 86")	
38.	153-994	1	SPECIAL ELBOW (20S-24H, XL)	
39.	157-260	1	ELBOW (20H-20QFX90, SPECIAL)	
40.	107-283	2	BOLT (1/4-NC X 3")	

OIL COOLER HYDRAULICS

REF NO.	PART NUMBER	QTY	DESCRIPTION	REMARKS
41.	105-229	1	BOLT (1/2-NC X 2")	
42.	105-884	1	WASHER (.531")	
43.	106-076	3	WASHER (1/4")	
44.	318-387	1	MOUNT	
45.	116-498	1	SHOCK MOUNT	
46.	105-085	4	LOCKWASHER (1/4-NC)	
47.	318-727	1	BRACKET	
48.	105-385	1	LOCK WASHER (5/8")	
49.	106-338	1	SCREW (M16-2.00 X 30MM)	

FOOTNOTES

1. HOSE REPLACED BY 514-177 CAP FOR JT MACH 1

NOTE

REFER TO O-RING CHART (800-301) IN BACK OF THE BOOK FOR REPLACEMENT OF O-RINGS.

OIL RETURN HYDRAULICS

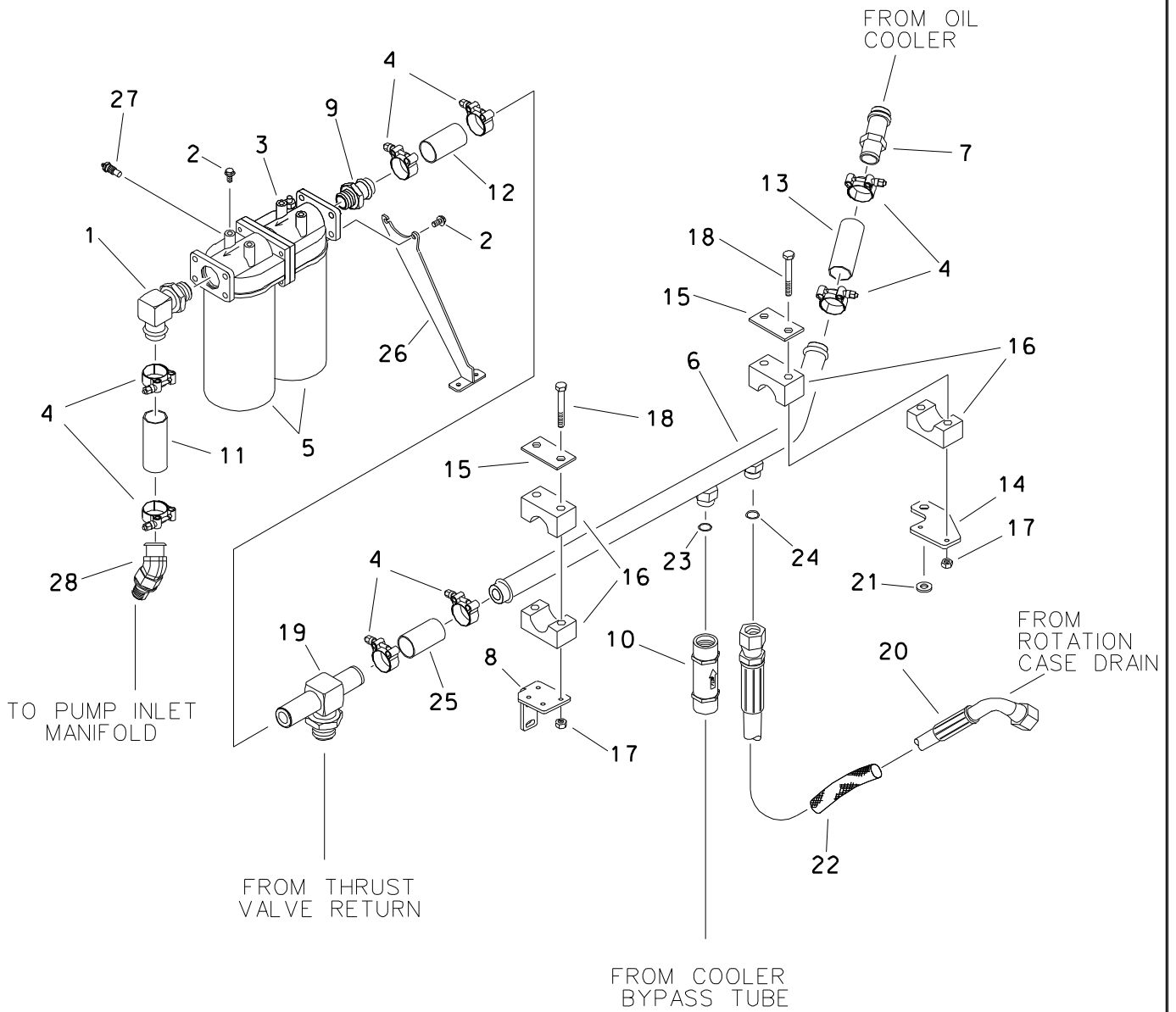

OIL RETURN HYDRAULICS

REF NO.	PART NUMBER	QTY	DESCRIPTION	REMARKS
1.	514-135	1	S/O COUPLER (24S-24H90)	
2.	105-825	6	FLG LK BOLT (3/8-NC X 3/4")	
3.	157-766	1	FILTER HEAD (20SF-20SF)	
4.	318-890	8	T-BLT CLP BRIDG 1.875 - 2.188	
5.	157-486	2	FILTER ELEMENT (10 MICRON)	
6.	156-876	1	HYD LINE	
7.	157-453	1	S/O COUPLER (20S-24H, LONG)	COOLER RETURN
8.	354-464	-	TOP REAR COOLANT BRACKET	
9.	514-138	1	S/O COUPLER (24S-24H)	
10.	153-436	1	FLOW CHECK (16SF-16SF)	FLOW ARROW ON CHECK VALVE MUST POINT UPWARD
11.	117-897	AR	BULK HOSE (1-1/2", SOLD PER 1')	USE 1 @ 10.0"
12.	117-897	AR	BULK HOSE (1-1/2", SOLD PER 1')	USE 2 @ 5.50"
13.	117-897	AR	BULK HOSE (1-1/2", SOLD PER 1')	USE 1 @ 18.50"
14.	354-465	1	TOP FRONT COOLANT BRACKET	
15.	322-362	2	BACKUP SPACER	
16.	111-008	2	BOLT-ON CLAMP (1-1/2", SET)	
17.	105-085	4	LOCKNUT (1/4-NC)	
18.	105-297	4	BOLT (1/4-NC X 3-1/4")	
19.	514-441	1	S/O BR TEE (160-24H-24H)	
20.	155-470	1	HOSE (12DFX90M-90"-3000)	
21.	105-940	1	WASHER (5/8")	
22.	115-924	1	ABRASION SLEEVE (1.59" X 88")	
23.	155-748	1	O-RING (916 D90)	
24.	157-017	1	O-RING (018 D90)	
25.	117-897	AR	BULK HOSE (1-1/2", SOLD PER 1')	USE 1 @ 9.0"
26.	318-481	1	SUPPORT	
27.	217-765	1	INDICATOR SWITCH	
28.	153-370	1	S/O COUPLER (24S-24H45)	

FOOTNOTES

NOTE
REFER TO O-RING CHART (800-301) IN BACK OF THE BOOK FOR REPLACEMENT OF O-RINGS.

HYDRAULIC RESERVOIR

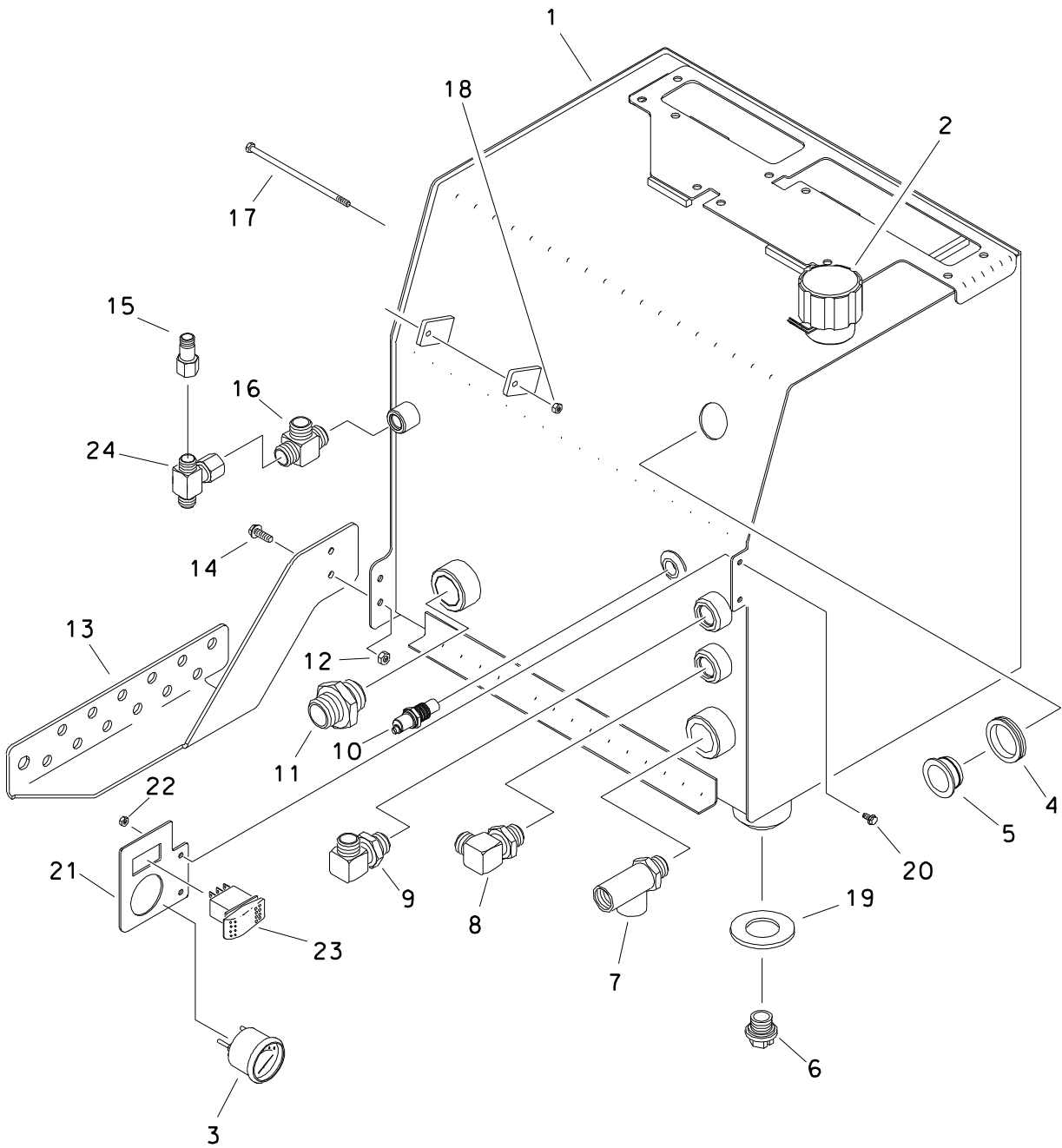

HYDRAULIC RESERVOIR

REF NO.	PART NUMBER	QTY	DESCRIPTION	REMARKS
1.	350-614	1	HYDRAULIC RESERVOIR	
2.	153-766	1	LOCKING CAP (VENTED)	USE PERMATEX AVIATION GASKET SEALER
3.	215-128	-	HOOR METER	AT ONLY
4.	115-320	1	GROMMET (1-1/2")	
5.	116-218	1	SIGHT GLASS (2")	INCL REFLECTOR, SEE FOOTNOTE 1
	360-849	-	REFLECTOR	
6.	149-398	1	DRAIN PLUG (1-UNF, .375 ORF)	
7.	153-899	1	RUN TEE (20S-16SF-16SF)	
8.	154-377	1	CONNECTOR (12S-16090)	
9.	154-286	1	CONNECTOR (12D-16S90)	
10.	214-819	1	TEMPERATURE SWITCH	USE 567 LOCTITE
11.	155-148	1	S/O COUPLER (20S-24H)	
12.	106-561	2	LOCKNUT (M8-1.25, PRV TRQ, 10.9)	
13.	354-466	1	BULKHEAD PLATE	
14.	106-162	2	FLG SCREW (M8-1.25 X 20MM)	
15.	154-262	-	REDUCER (060-080F)	
16.	154-299	-	RUN TEE (08S-080-080)	
17.	106-061	1	BOLT (1/4-NC X 6-1/2")	
18.	105-085	1	LOCKNUT (1/4-NC)	
19.	149-829	1	1" SEAL WASHER	
20.	106-986	2	FLG LK SCREW (M6-1.00 X 12MM)	AT ONLY
21.	313-873	1	GAUGE PANEL	AT ONLY
22.	106-106	2	NUT (M6-1.00)	AT ONLY
23.	217-912	-	ROCKER SWITCH (DPDT) ON-ON-ON	AT ONLY
24.	154-257	1	UN BR TEE (080FX-080-080)	

FOOTNOTES

1. REFER TO SPECIAL TOOL DIAGRAM 052-524, FOR INSTALLATION.

NOTE:

REFER TO O-RING CHART (800-301) IN BACK OF THE BOOK FOR REPLACEMENT OF O-RINGS.

ROTATION, THRUST AND MUD GAUGES

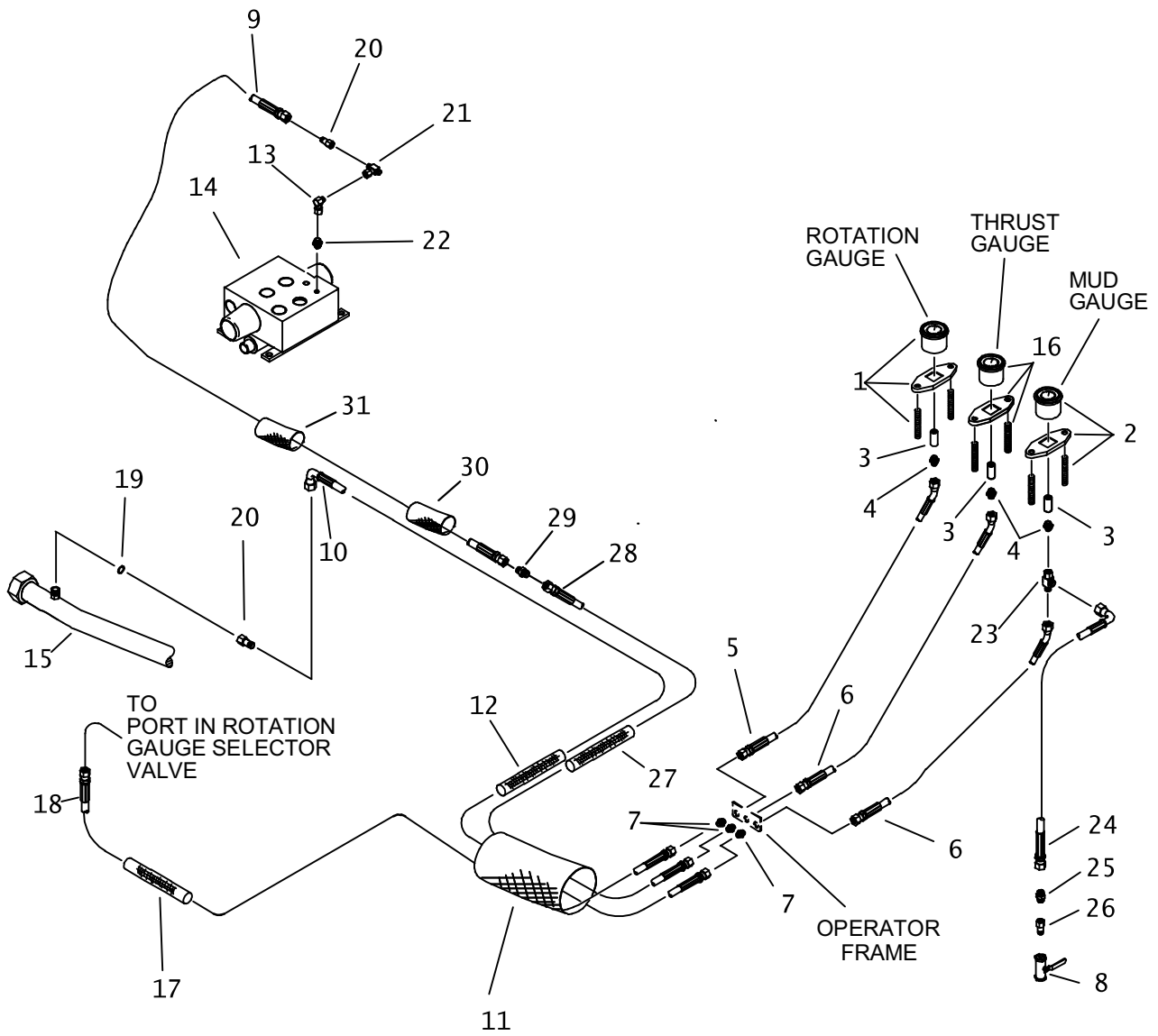

ROTATION, THRUST AND MUD GAUGES

REF NO.	PART NUMBER	QTY	DESCRIPTION	REMARKS
1.	258-061	1	HYD PRESSURE GAUGE (6000 PSI)	
2.	150-1964	1	PRESSURE GAUGE (2000PSI)	
3.	514-408	3	COLLAR (04NF)	
4.	154-339	3	CONNECTOR (04N-040)	
5.	515-646	1	HOSE (040FX45-62"-10000)	
6.	515-283	2	HOSE (040FX45-62"-3000)	
7.	154-275	3	BK CONNECTOR (040-040BK)	
8.	120-071	1	SHUT-OFF (04NF-04NF)	
9.	515-161	1	HOSE (040FX-160"-3000)	
	150-1980	1	HOSE (040FX-282"-3000)	USE ON 4020 WITH RACK AND PINION. SEE FOOTNOTE 4
10.	515-137	1	HOSE (040FX90-90"-3000)	
11.	117-283	1	ABRASION SLEEVE (4.000" X 20")	
12.	117-209	1	ABRASION SLEEVE (1.00" X 90")	
13.	154-228	-	UNION (060-060FX90)	
14.	157-440	-	THRUST VALVE (ELECTRIC)	SEE FOOTNOTE 2
	150-1458	-	THRUST VALVE (ELECTRIC)	SEE FOOTNOTE 3
	500-1290	-	THRUST VALVE COIL	
15.	156-892	-	HYDRAULIC LINE (-24)	
16.	258-063	1	GAUGE (4000 PSI)	
17.	117-792	1	ABRASION SLEEVE (1.00" X 115")	
18.	153-730	1	HOSE (040FX-116"-6000)	SEE FOOTNOTE 1
19.	157-038	1	O-RING (012 D90)	
20.	154-373	2	REDUCER (040-060F)	
21.	154-348	-	UNION BRANCH TEE (060FX-060-060)	
22.	154-411	-	CONNECTOR (04S-060)	
23.	154-265	1	UNION RUN TEE (040FX-040-040)	
24.	515-179	1	HOSE (040FX90-11"-3000)	
25.	153-238	1	BK CONNECTOR (040-06S)	
26.	153-264	1	REDUCER (04N-06SF)	
27.	117-400	1	ABRASION SLEEVE (1.00" X 72")	
28.	515-330	1	HOSE (040FX45-76"-3000-AR)	
29.	154-275	1	BK CONNECTOR (040 -040BK)	
30.	117-612	1	ABRASION SLEEVE (1.00" X 46")	
31.	117-1019	1	ABRASION SLEEVE (1.25" X 234")	

FOOTNOTES:

- HOSE CONNECTS TO PUMP FOR JT4020 MACH I
- ENDS WITH S/N: CMWJ42T2J60000023; CMWA42T2E60000029; CMWA40T3P60000002; CMWJ40T3T60000001
- BEGINS WITH S/N: CMWA40T3K60000003; CMWJ40T3P60000002
- CONNECTS AT MAIN FRAME BULKHEAD

NOTE:

REFER TO O-RING CHART (800-301) IN BACK OF THE BOOK FOR REPLACEMENT OF O-RINGS.

MAIN FRAME BULKHEADS

ENDS WITH S/N CMWA40T3C70000014
ENDS WITH S/N CMWJ40T3L70000025

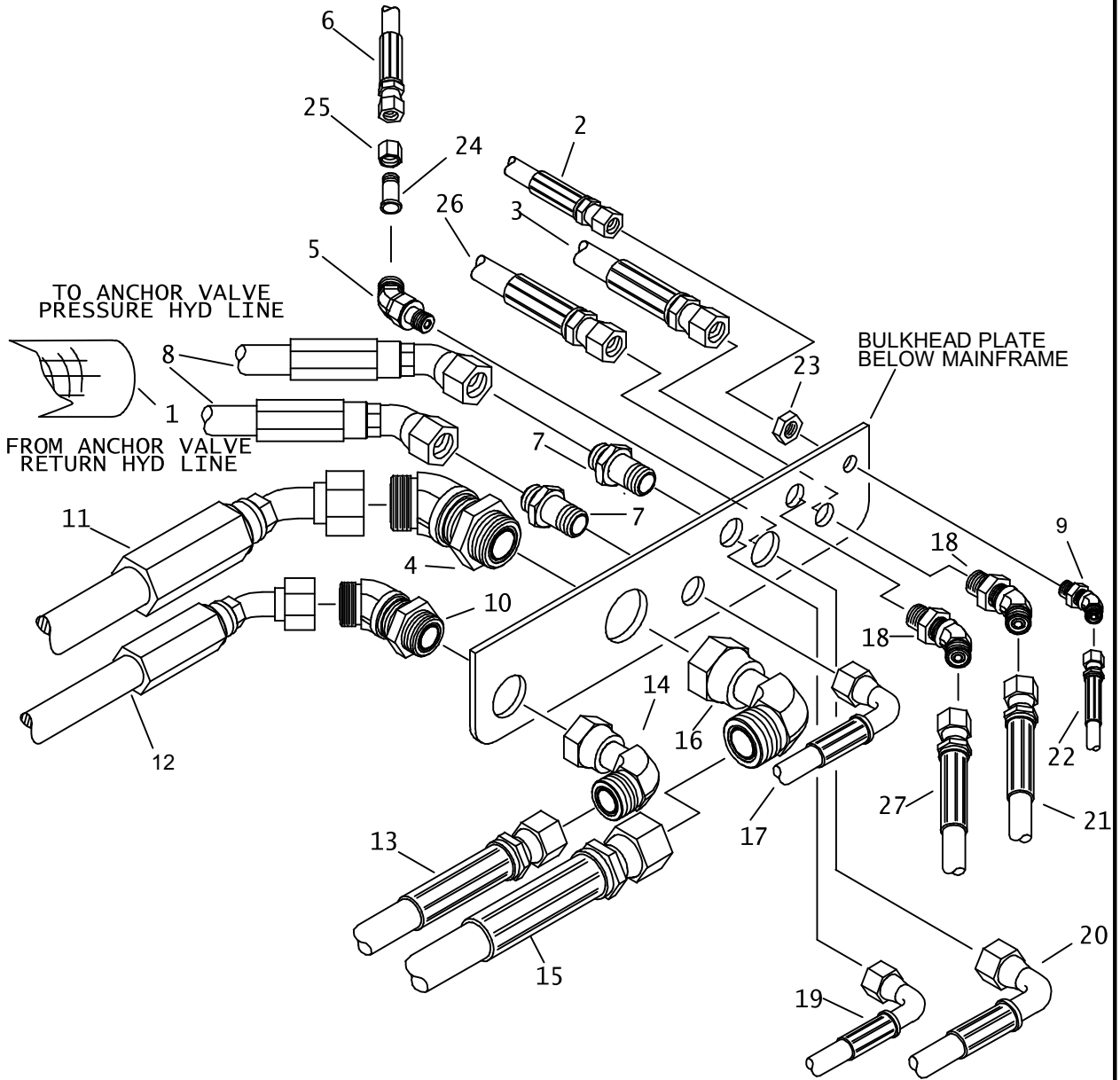

MAINFRAME BULKHEADS

ENDS WITH S/N CMWA40T3C70000014
ENDS WITH S/N CMWJ40T3L70000025

REF NO.	PART NUMBER	QTY	DESCRIPTION	REMARKS
1.	115-899	1	ABRASION SLEEVE (2.5 " X 54")	
2.	154-651	-	HOSE (040FX-66"-3000)	TO HARD LINE TO SERIES PARALLEL VALVE
3.	515-141	-	HOSE (080FX90-82"-3000)	TO PIPE LOADER VALVE
4.	153-395	1	BK CONNECTOR (200-20045)	
5.	154-448	1	BK CONNECTOR (120-12045BK)	
6.	515-750	-	HOSE (060FX-210"-3000)	FROM ROTATION MOTOR CASE DRAIN
7.	154-309	2	BK CONNECTOR (100-100BK)	
8.	515-671	-	HOSE (100FX45-52"-3000)	SEE GRAPHICS
9.	154-285	1	BK CONNECTOR (040-04045BK)	
10.	514-242	1	BK CONNECTOR (160-16045BK)	
11.	157-499	-	HOSE (200FX-47"-3000, SPECIAL)	TO THRUST VALVE, SUPPLY
12.	515-655	-	HOSE (160FX90-47"-3000)	FROM THRUST VALVE, RETURN
13.	154-815	-	HOSE (160FX-48"-4000)	TO RETURN LINE (BEFORE FILTERS)
14.	154-290	1	UNION (160-160FX90)	
15.	157-754	-	HOSE (200FX45-27"-3000, SPEC)	FROM LOAD SENSE PUMP
16.	514-422	1	CONNECTOR (200-200FX90)	
17.	515-690	-	HOSE (100FX90L-58"-3000)	TO COOLER TUBE
18.	154-393	2	BK CONNECTOR (080-08045BK)	
19.	515-454	-	HOSE (100FX90L-20"-3000)	FROM LOAD SENSE PUMP
20.	155-470	-	HOSE (120FX90M-90"-3000)	TO UPPER COOLER TUBE
21.	515-140	-	HOSE (080FX90-56"-3000)	FROM HYDRAULIC CONTROL VALVE ON HYD TANK
22.	154-692	-	HOSE (040FX-54"-3000)	FROM THRUST SHIFT SOLENOID VALVE
23.	105-431	1	JAM NUT (9/16-NF)	
24.	154-459	1	REDUCER STEM (060)	
25.	154-271	1	REDUCER NUT (120F)	
26.	515-741	1	HOSE (080FX90S-112"-3000)	FROM DRAIN ON LOADER VALVE
27.	154-739	1	HOSE (080FX-32"-3000)	

NOT SHOWN:

FOOTNOTES:

NOTE:

REFER TO O-RING CHART (800-301) IN BACK OF THE BOOK FOR REPLACEMENT OF O-RINGS.

ROTATION HYDRAULICS

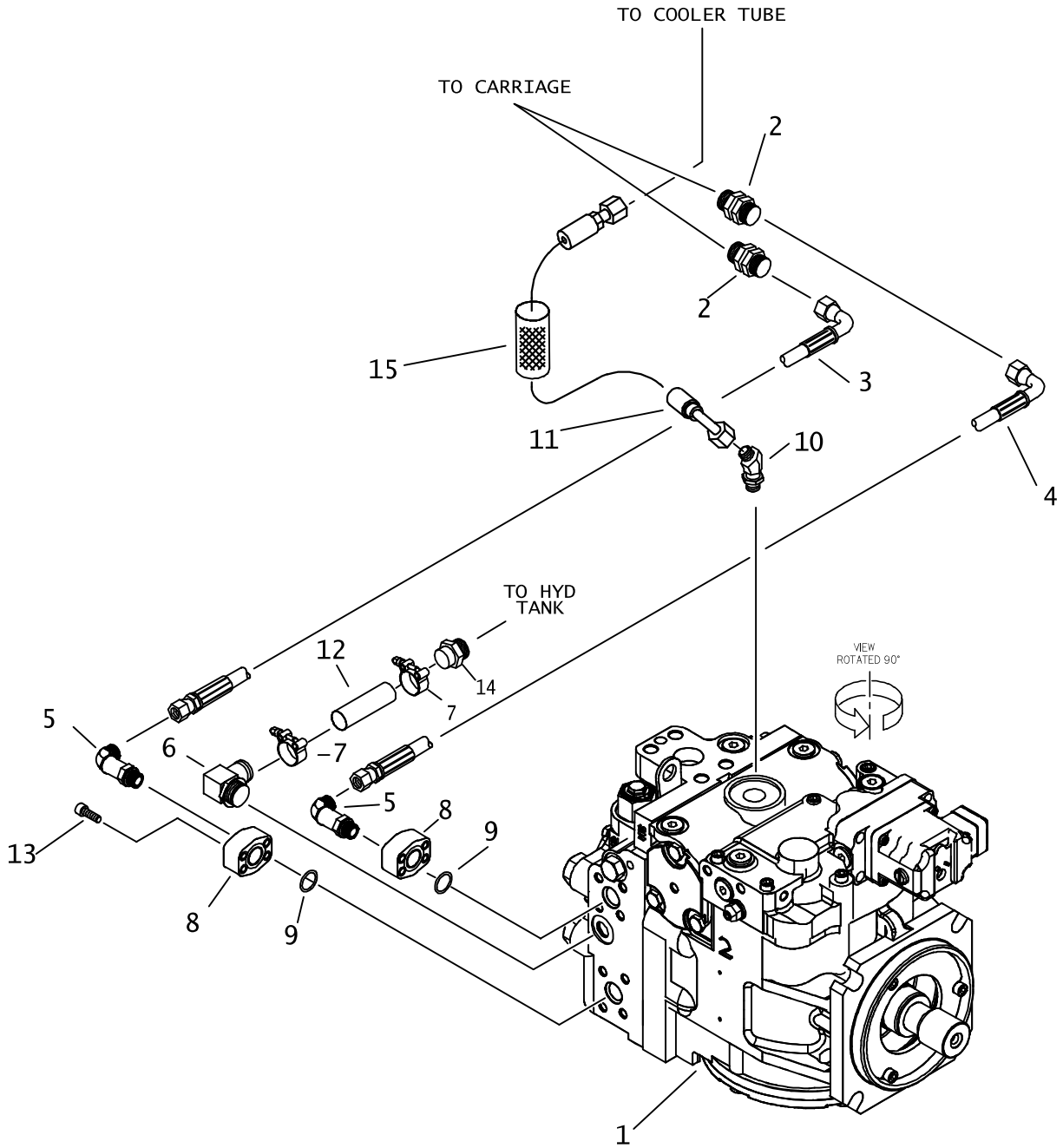

ROTATION HYDRAULICS

REF NO.	PART NUMBER	QTY	DESCRIPTION	REMARKS
1.	153-340	-	HYDRAULIC PUMP	SEAL KIT I90-764
2.	154-389	2	BK CONNECTOR (160-160BK)	
3.	515-666	1	HOSE (160FX90-52"-6000)	
4.	154-763	1	HOSE (160FX90S-54"-6000)	
5.	154-289	2	CONNECTOR (16S-16090, XL)	
6.	155-176	1	S/O COUPLER (20H-24S90)	
7.	111-028	2	T-BOLT CLAMP (1.75"-2.00")	
8.	514-245	2	HEAD FLANGE (16HFL-16SF)	
9.	157-029	2	O-RING (219 D90)	
10.	154-371	1	CONNECTOR (12S-16045)	
11.	156-177	1	HOSE (160FX45-38"-200)	CASE DRAIN
12.	116-588	AR	BULK HOSE (1-1/2", SOLD PER FT)	USE 1 @ 18.5"
13.	105-918	8	BOLT (7/16-NC X 1-1/2", SOC)	
14.	155-148	-	S/O COUPLER (20S-24H)	
15.	117-654	1	ABRASION SLEEVE (1.75" X 38")	

NOT SHOWN:

FOOTNOTES:

NOTE:

REFER TO O-RING CHART (800-301) IN BACK OF THE BOOK FOR REPLACEMENT OF O-RINGS.

STATION GAUGE VALVE

JT4020 ALL TERRAIN ONLY

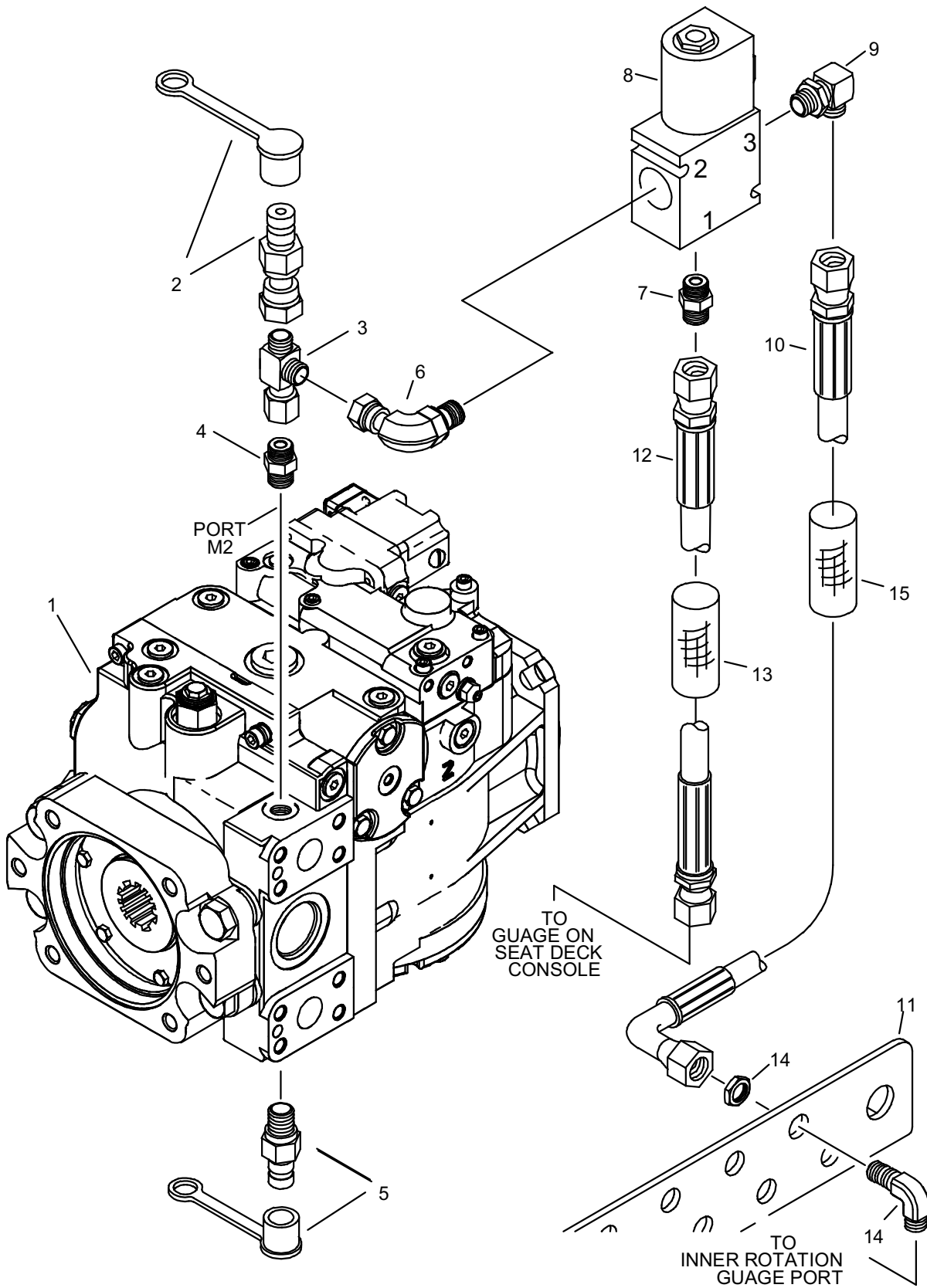

STATION GAUGE VALVE

JT4020 ALL TERRAIN ONLY

REF NO.	PART NUMBER	QTY	DESCRIPTION	REMARKS
1.	153-340	-	HYDRAULIC PUMP	
2.	159-157	1	QDC ADAPTER (02-060F)	
	159-148	-	DUST CAP (1/8")	
3.	154-344	1	UN RUN TEE (060FX-060-060)	
4.	154-221	1	CONNECTOR (06S-060)	
5.	159-147	1	QDC ADAPTER (02-06S)	
	159-148	-	DUST CAP (1/8")	
6.	154-343	1	UNION (06S-060FX90)	
7.	154-220	1	CONNECTOR (040-06S)	
8.	153-771	1	HYDRAULIC VALVE	
9.	154-226	1	CONNECTOR (040-06S90)	
10.	515-437	1	HOSE (040FX90-21"-3000)	
11.	354-466	-	BULKHEAD PLATE	
12.	153-730	-	HOSE (040FX-116"-6000)	
13.	117-792	-	ABRASION SLEEVE (1.00" X 115")	
14.	154-355	1	BK CONNECTOR (040-04090BK)	
15.	117-566	1	ABRASION SLEEVE (1.25" X 11")	

NOT SHOWN:

FOOTNOTES:

NOTE:

REFER TO O-RING CHART (800-301) IN BACK OF THE BOOK FOR REPLACEMENT OF O-RINGS.

ROTATION TEST PORTS

JT4020 MACH 1 ONLY

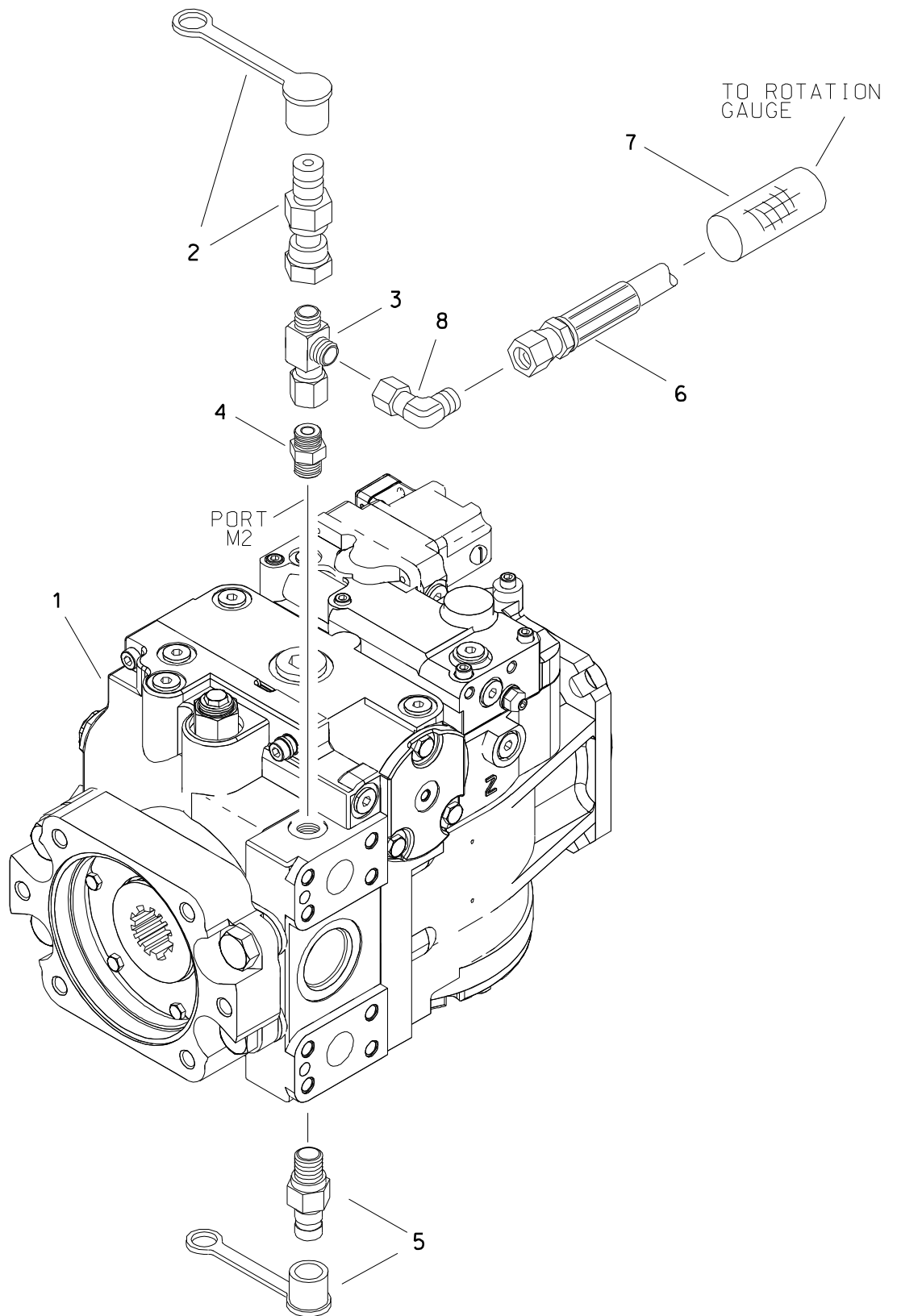

ROTATION TEST PORTS

JT4020 MACH 1 ONLY

REF NO.	PART NUMBER	QTY	DESCRIPTION	REMARKS
1.	153-340	1	HYDRAULIC PUMP	
2.	159-156	1	QDC ADAPTER (02-040F)	
	159-148	-	DUST CAP (1/8")	
3.	154-265	1	UN RUN TEE (040FX-040-040)	
4.	154-220	1	CONNECTOR (040-06S)	
5.	159-147	1	QDC ADAPTER (02-06S)	
	159-148	-	DUST CAP (1/8")	
6.	153-730	1	HOSE (040FX-116"-6000)	
7.	117-792	1	ABRASION SLEEVE (1.00" X 115")	
8.	154-255	1	UNION (040-040FX90)	

FOOTNOTES

REFER TO O-RING CHART (800-301) IN BACK OF THE BOOK FOR REPLACEMENT OF O-RINGS.

INNER SPINDLE ROTATION GAUGE

JT4020 ALL TERRAIN ONLY

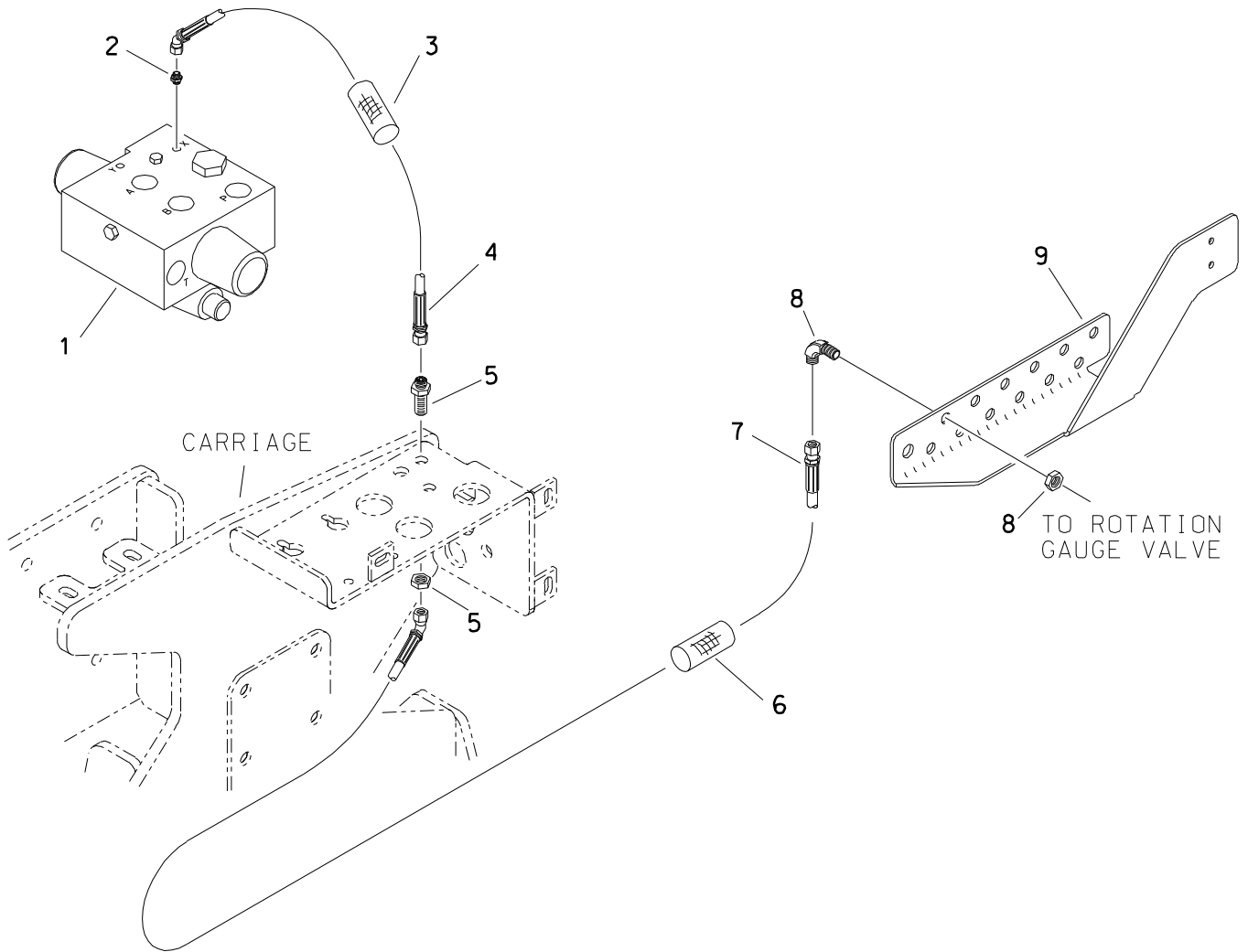

INNER SPINDLE ROTATION GAUGE JT4020 ALL TERRAIN ONLY

REF NO.	PART NUMBER	QTY	DESCRIPTION	REMARKS
1.	153-773	-	HYDRAULIC VALVE	
2.	154-278	1	CONNECTOR (04S-040)	
3.	117-409	1	ABRASION SLEEVE (1.00" X 28")	
4.	153-073	1	HOSE (040FX45-28"-3000)	
5.	154-275	1	BK CONNECTOR (040-040BK)	
6.	117-693	1	ABRASION SLEEVE (1.00" X 60")	
7.	153-748	1	HOSE (040FX45-212"-3000)	
8.	154-355	-	BK CONNECTOR (040-04090BK)	
9.	354-466	-	BULKHEAD PLATE	

FOOTNOTES

OUTER ROTATION HYDRAULICS

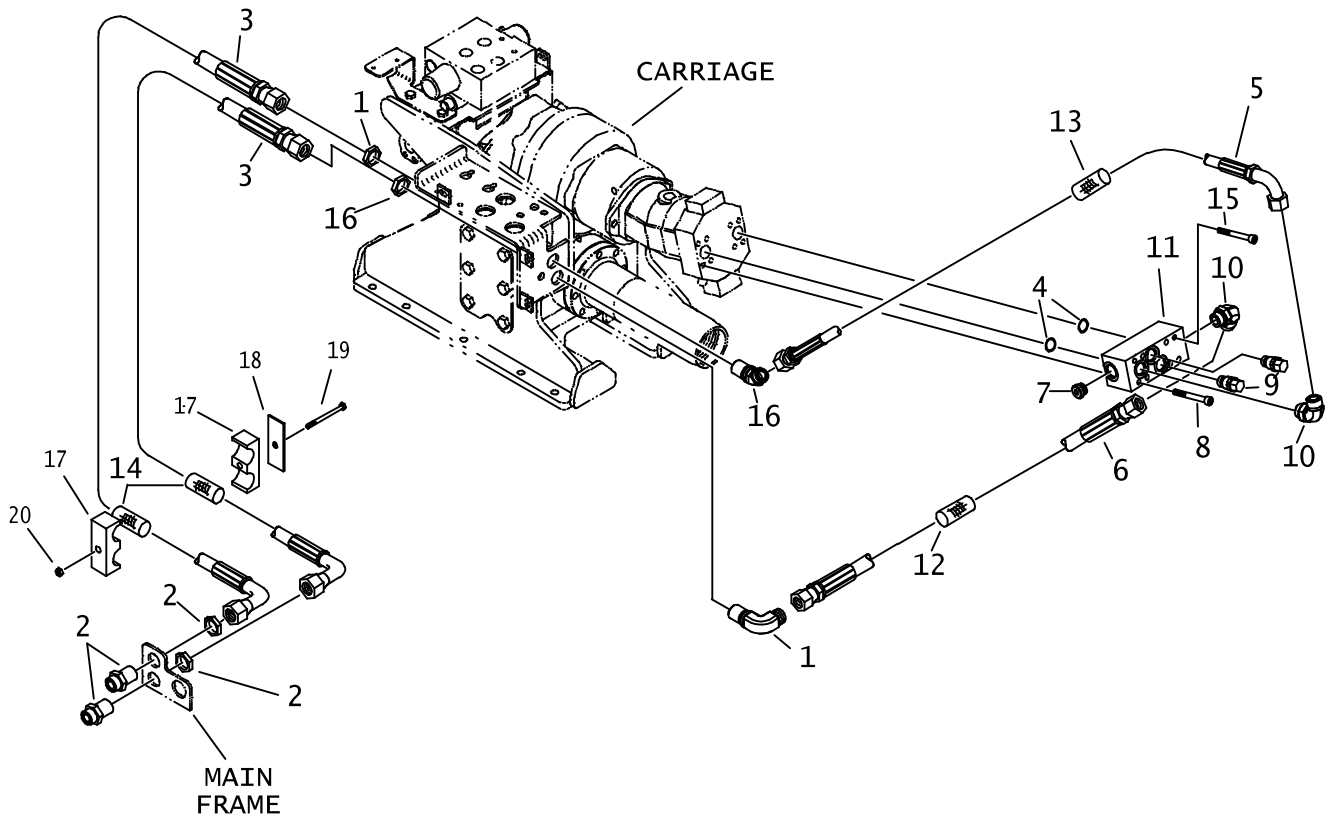

OUTER ROTATION HYDRAULICS

REF NO.	PART NUMBER	QTY	DESCRIPTION	REMARKS
1.	154-419	1	BK CONNECTOR (160-16090BK)	
2.	154-389	3	BK CONNECTOR (160-160BK)	
3.	153-744	2	HOSE (160FX90S-229"-6000)	
	150-1702	2	HOSE (160FX90S-299"-6000)	SEE FOOTNOTE 2
4.	157-029	2	O-RING (219 D90)	
5.	157-364	1	HOSE (160FX90S-18.75"-6000)	
6.	153-743	1	HOSE (160FX-24"-6000)	
7.	155-184	1	PLUG (16S)	
8.	107-806	4	SCR (7/16-NC X 3.50, SOC, GD8)	USE LOCTITE 242, TORQUE TO 85 FT LB
9.	149-566	2	HYDRAULIC VALVE	SEE FOOTNOTE 1
	191-031	-	SEAL REPAIR KIT	
10.	154-287	2	CONNECTOR (16S-16090)	
11.	157-363	1	CARTRIDGE MANIFOLD	
12.	117-675	1	ABRASION SLEEVE (1.75" X 24")	
13.	117-564	1	ABRASION SLEEVE (1.75" X 15")	
14.	117-292	2	ABRASION SLEEVE (2.07" X 70")	
15.	107-535	4	SCR (7/16-NC X 3.75, SOC, GD8)	USE LOCTITE 242, TORQUE TO 85 FT LBS
16.	514-242	1	BK CONNECTOR (160-16045BK)	
17.	110-359	1	BOLT-ON CLAMP (1-1/2", SET)	
18.	315-623	1	BACKUP SPACER	
19.	107-078	1	SCREW (M8-1.25 X 90MM)	
20.	106-561	1	LOCKNUT (M8-1.25, PRV TRQ, 10.9)	

NOT SHOWN:

FOOTNOTES:

1. TORQUE TO 80-90 FT LBS; TIGHTEN ONLY AT BASE DEEP SOCKET
2. USE ON 4020 WITH RACK AND PINION

NOTE:

- * REFER TO O-RING CHART (800-301) IN BACK OF THE BOOK FOR REPLACEMENT OF O-RINGS.
- * SEE PARTS PAGE ID0203288 FOR S/N BEGINNING WITH CMWJ40T3E80000063 & ENDING WITH S/N CMWJ40T3E80000082

OUTER ROTATION HYDRAULICS

BEGINS WITH S/N: CMWJ40T3E80000063

ENDS WITH S/N: CMWJ40T3T80000082

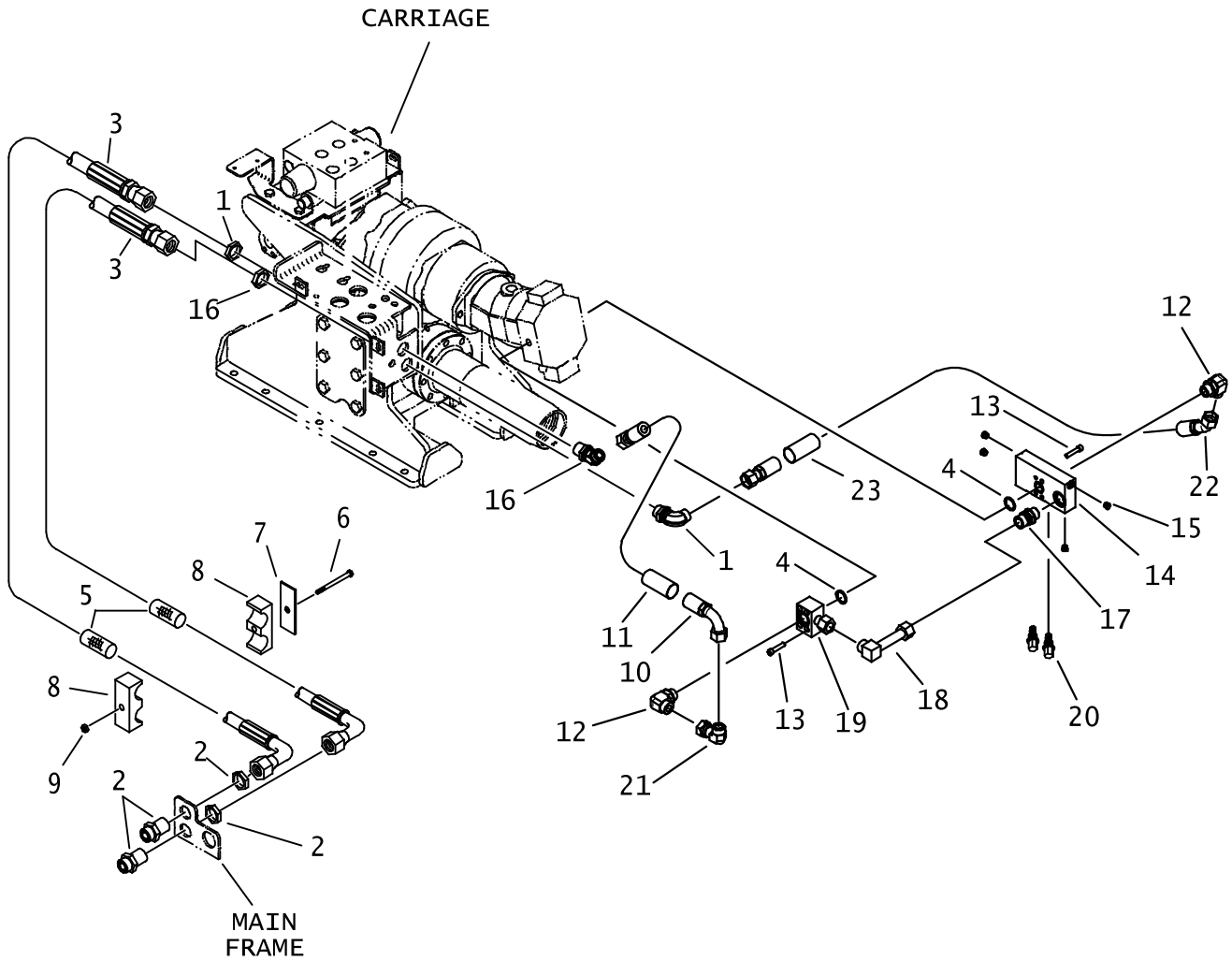

OUTER ROTATION HYDRAULICS

BEGINS WITH S/N: CMWJ40T3E80000063

ENDS WITH S/N: CMWJ40T3T80000082

REF NO.	PART NUMBER	QTY	DESCRIPTION	REMARKS
1.	154-419	1	BK CONNECTOR (160-16090BK)	
2.	154-389	3	BK CONNECTOR (160-160BK)	
3.	150-1702	2	HOSE (160FX90S-299"-6000)	
4.	157-029	2	O-RING (219 D90)	
5.	117-292	2	ABRASION SLEEVE (2.07" X 70")	
6.	107-078	1	SCREW (M8-1.25 X 90MM)	
7.	315-623	1	BACKUP SPACER	
8.	110-359	1	BOLT-ON CLAMP (1-1/2", SET)	
9.	106-561	1	LOCKNUT (M8-1.25, PRV TRQ, 10.9)	
10.	150-2142	1	HOSE (160FX90-14"-6000)	
11.	117-564	1	ABRASION SLEEVE (1.75" X 15")	
12.	154-287	2	CONNECTOR (16S-16090)	
13.	106-804	8	SCREW (7/16-NC X 2", SOC, GR8)	USE LOCTITE 242 TORQUE TO 85 FT LBS
14.	149-589	1	CARTRIDGE MANIFOLD	
15.	154-384	4	PLUG (06S)	
16.	514-242	1	BK CONNECTOR (160-16045BK)	
17.	149-377	1	HYDRAULIC ADAPTER, SPECIAL	
18.	149-425	1	UNION (160-16090, SPECIAL)	
19.	149-376	1	ADAPTER MANIFOLD	
20.	149-566	2	HYDRAULIC VALVE	TORQUE TO 80-90 FT. LBS, TIGHTEN ONLY AT BASE WITH DEEP SOCKET
21.	154-290	1	UNION (160-160FX90)	
22.	150-2143	1	HOSE (160FX45-19"-6000)	
23.	117-794	1	ABRASION SLEEVE (1.75" X 18")	

NOT SHOWN:

FOOTNOTES:

NOTE:

REFER TO O-RING CHART (800-301) IN BACK OF THE BOOK FOR REPLACEMENT OF O-RINGS.

INNER/OUTER SPINDLE DRIVE CASE DRAIN

ENDS WITH S/N CMWA40T3C7000014

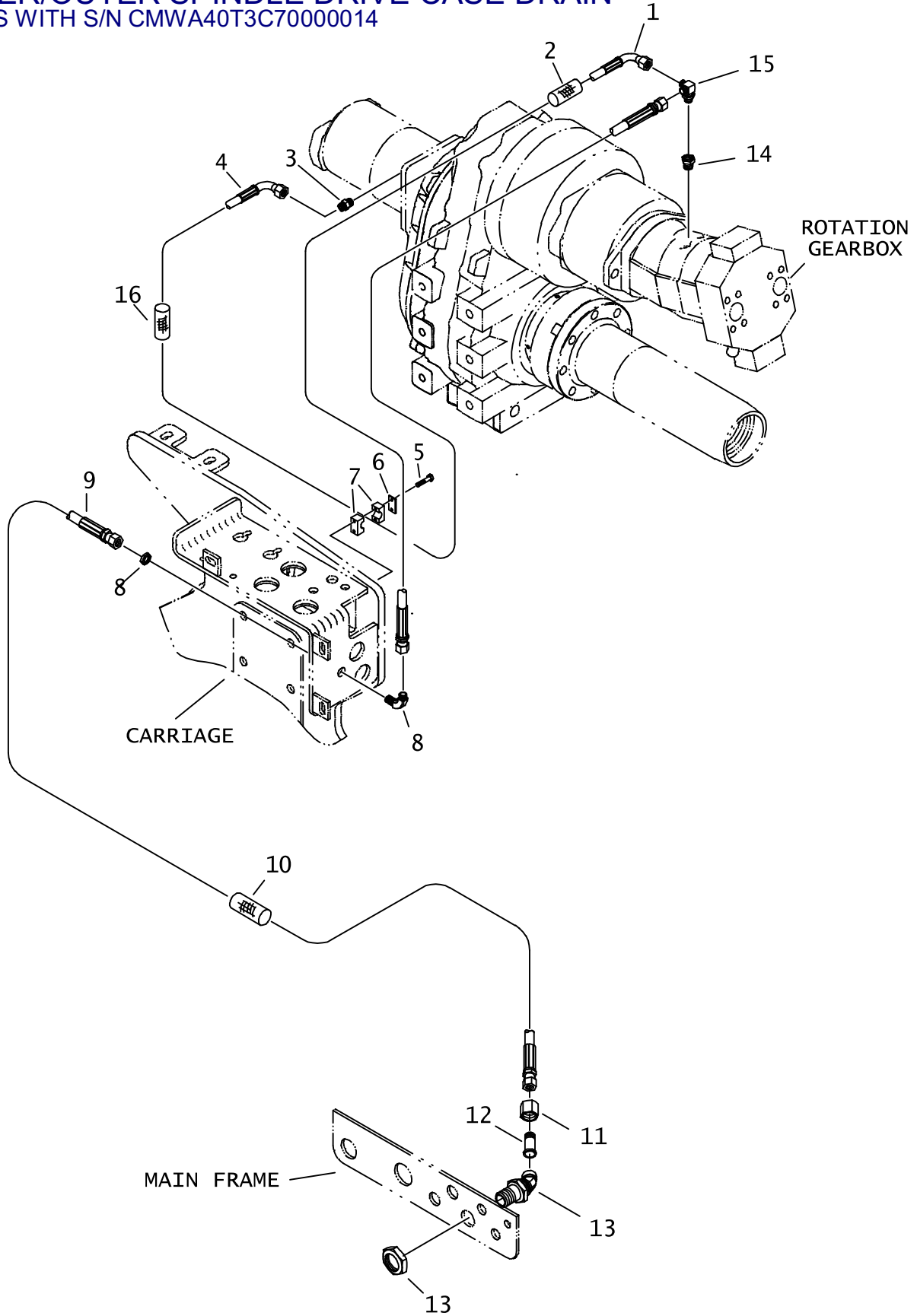

INNER/OUTER SPINDLE DRIVE CASE DRAIN ENDS WITH S/N CMWA40T3C70000014

REF NO.	PART NUMBER	QTY	DESCRIPTION	REMARKS
1.	153-768	1	HOSE (060FX90S-18"-3000)	
2.	117-328	1	ABRASION SLEEVE (1.00" X 18")	
3.	156-174	1	CONNECTOR (06S-060)	AT ONLY
4.	153-769	1	HOSE (060FX90L-33"-3000)	AT ONLY
5.	105-818	2	BOLT (1/4-NC X 1-1/2")	AT ONLY
6.	322-289	1	BACKUP (BOLT-ON)	AT ONLY
7.	110-411	1	BOLT-ON CLAMP (3/4", SET)	AT ONLY
8.	154-229	1	BK CONNECTOR (060-06090BK)	
9.	515-750	1	HOSE (060FX-210"-3000)	
10.	117-416	1	ABRASION SLEEVE (1.00" X 50")	
11.	154-271	1	REDUCER NUT (120F)	
12.	154-459	1	REDUCER STEM (060)	
13.	154-448	1	BK CONNECTOR (120-12045BK)	
14.	153-770	1	REDUCER (12S-08SF)	
15.	514-051	1	BRANCH TEE (08S-060-060)	AT ONLY
	157-381	-	CONNECTOR (08S-06090S)	JT ONLY
16.	117-411	1	ABRASION SLEEVE (1.00" X 32")	AT ONLY

NOT SHOWN:

FOOTNOTES:

NOTE:

REMOTE FILTER

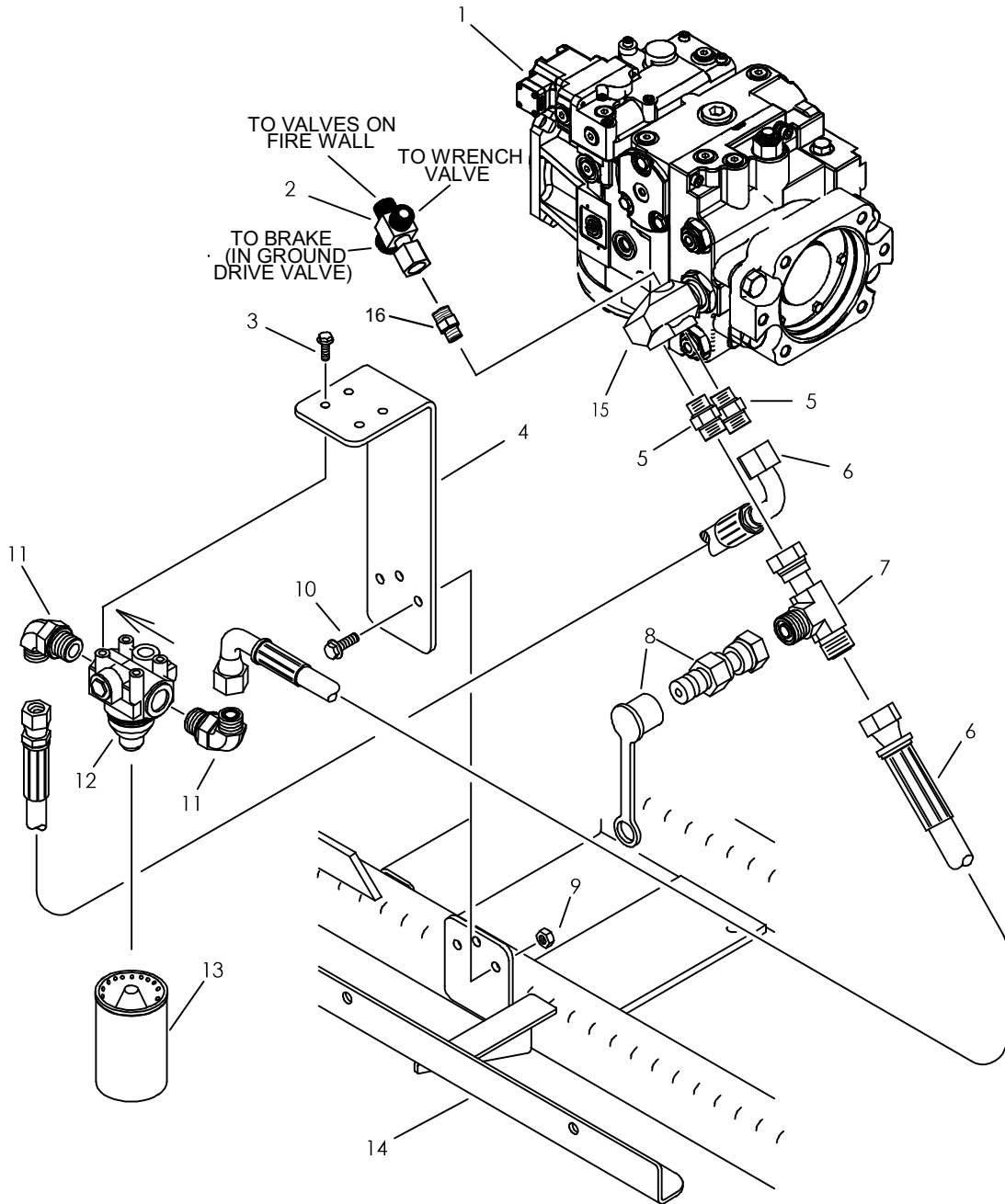

REMOTE FILTER

REF NO.	PART NUMBER	QTY	DESCRIPTION	REMARKS
1.	153-340	-	HYDRAULIC PUMP	INCLUDES ITEM 15
2.	150-1097	1	CROSS (F060-060-080-060)	
3.	105-823	4	FLG LK BOLT (5/16-NC X 3/4")	
4.	310-571	1	CHARGE FILTER BRACKET	
5.	154-301	2	CONNECTOR (10S-100)	
6.	153-268	2	HOSE (100FX90S-24"-1500)	
7.	154-488	1	UN RUN TEE (100FX-100-100)	
8.	159-159	1	QDC ADAPTER (02-100FX)	
	159-148	-	DUST CAP (1/8")	
9.	105-894	3	LOCKNUT(M10-1.50, PRV TRQ, 10.9)	
10.	106-724	3	FLG SCREW (M10-1.50 X 25MM)	
11.	154-300	2	CONNECTOR (100-12S90)	
12.	153-050	1	FILTER HEAD (12 SF)	
13.	149-939	1	FILTER	
14.	354-597	-	ENGINE SKID	
15.	149-845	-	REMOTE FILTRATION KIT (75/100)	PART OF ITEM 1, INCLUDES O-RING
16.	154-221	-	CONNECTOR (06S-060)	

NOT SHOWN:

FOOTNOTES:

NOTE:

REFER TO O-RING CHART (800-301) IN BACK OF THE BOOK FOR REPLACEMENT OF O-RINGS.

2 SPEED TRACK AND THRUST

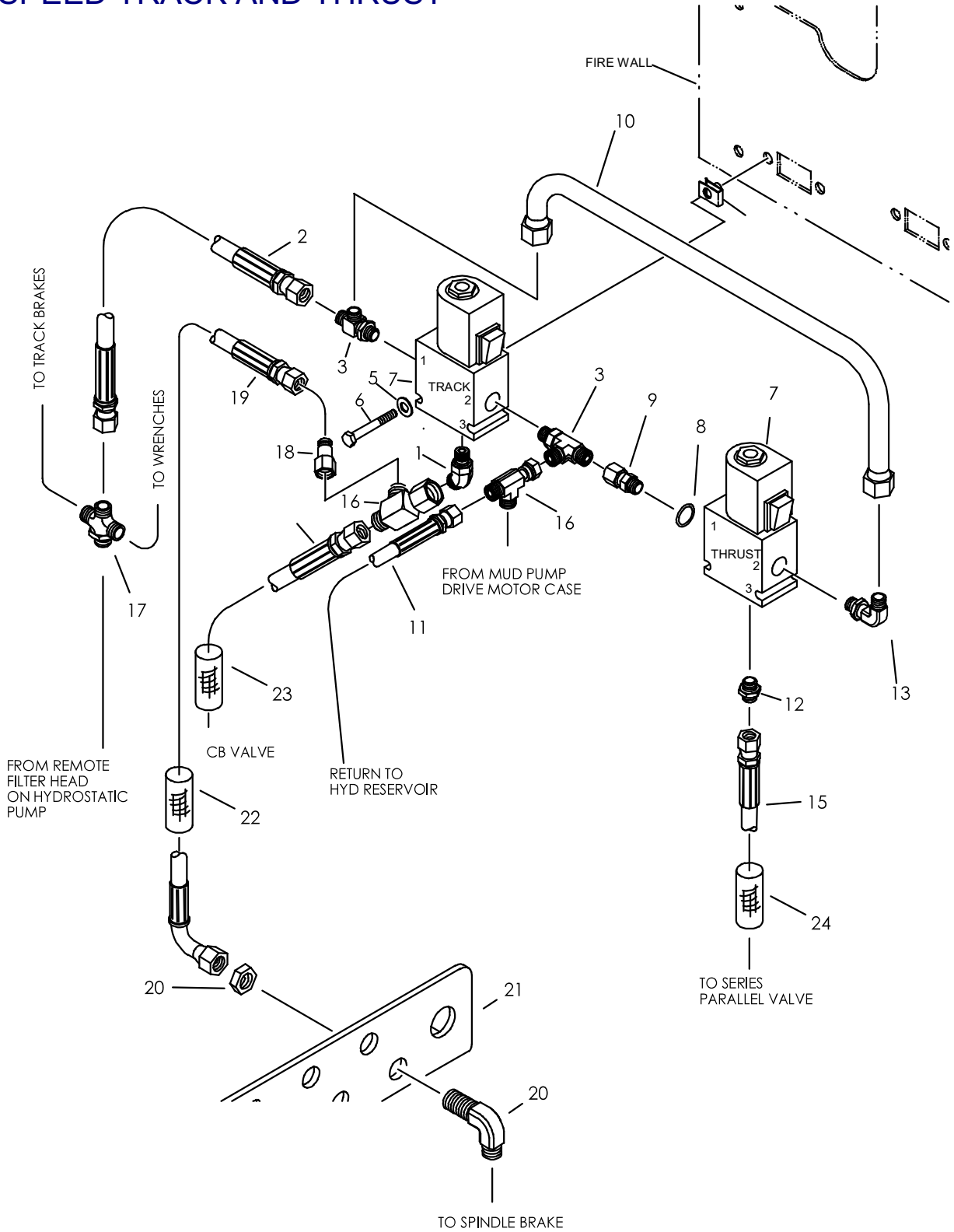

2 SPEED TRACK AND THRUST

REF NO.	PART NUMBER	QTY	DESCRIPTION	REMARKS
1.	154-224	1	CONNECTOR (06S-06045)	
2.	154-832	1	HOSE (060FX-23"-3000)	
3.	154-345	2	RUN TEE (06S-060-060)	
4.	106-574	4	CLIP NUT (M6-1.00)	
5.	106-076	4	WASHER (1/4")	
6.	107-025	4	SCREW (M6-1.0 X 50mm)	
7.	158-627	2	SOLENOID VALVE	
	500-756	1	SEAL REPAIR KIT	
	217-770	1	SOLENOID COIL	
	158-636	1	SOLENOID VALVE CARTRIDGE	
8.	155-705	1	O-RING (906 D90)	
9.	514-409	1	UNION (06J-060FX)	
10.	156-295	1	HYD LINE (-6)	
11.	515-221	1	HOSE (060FX90S-28"-3000)	
12.	154-220	1	CONNECTOR (040-06S)	
13.	154-342	1	CONNECTOR (06S-06090)	
14.	154-806	1	HOSE (060FX-54"-3000)	
15.	154-692	1	HOSE (040FX-54"-3000)	
16.	154-344	2	UN RUN TEE (060FX-060-060)	
17.	149-847	-	CROSS (06S-060-060-080)	
18.	154-373	1	REDUCER (040-060F)	
19.	154-727	1	HOSE (040FX90-30"-3000)	
20.	154-355	1	BK CONNECTOR (040-04090BK)	
21.	354-466	1	BULKHEAD PLATE	
22.	117-396	1	ABRASION SLEEVE (1.25" X 28")	
23.	117-395	1	ABRASION SLEEVE (1.25" X 50")	
24.	117-714	1	ABRASION SLEEVE (1.00" X 54")	

NOT SHOWN:

FOOTNOTES:

NOTE:

REFER TO O-RING CHART (800-301) IN BACK OF THE BOOK FOR REPLACEMENT OF O-RINGS.

SPINDLE BRAKE

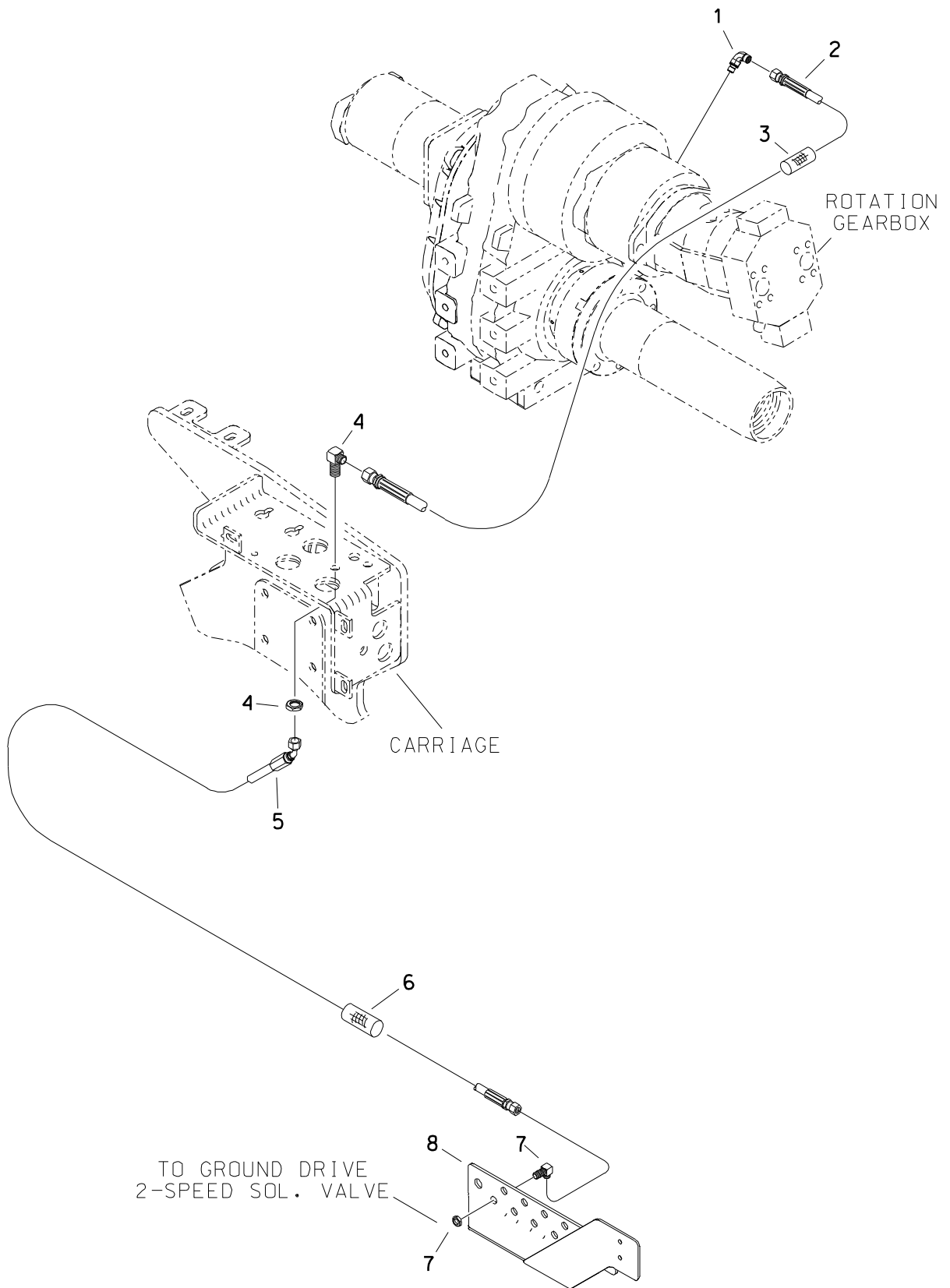

SPINDLE BRAKE

REF NO.	PART NUMBER	QTY	DESCRIPTION	REMARKS
1.	154-252	1	CONNECTOR (04S-04090)	
2.	515-543	1	HOSE (040FX-21"-3000)	
3.	117-607	1	ABRASION SLEEVE (1.00" X 21")	
4.	154-355	1	BK CONNECTOR (040-04090BK)	
5.	153-748	1	HOSE (040FX45-212"-3000)	
6.	117-693	1	ABRASION SLEEVE (1.00" X 60")	
7.	154-355	1	BK CONNECTOR (040-04090BK)	
8.	354-466	-	BULKHEAD PLATE	

FOOTNOTES

TRACK SHIFT

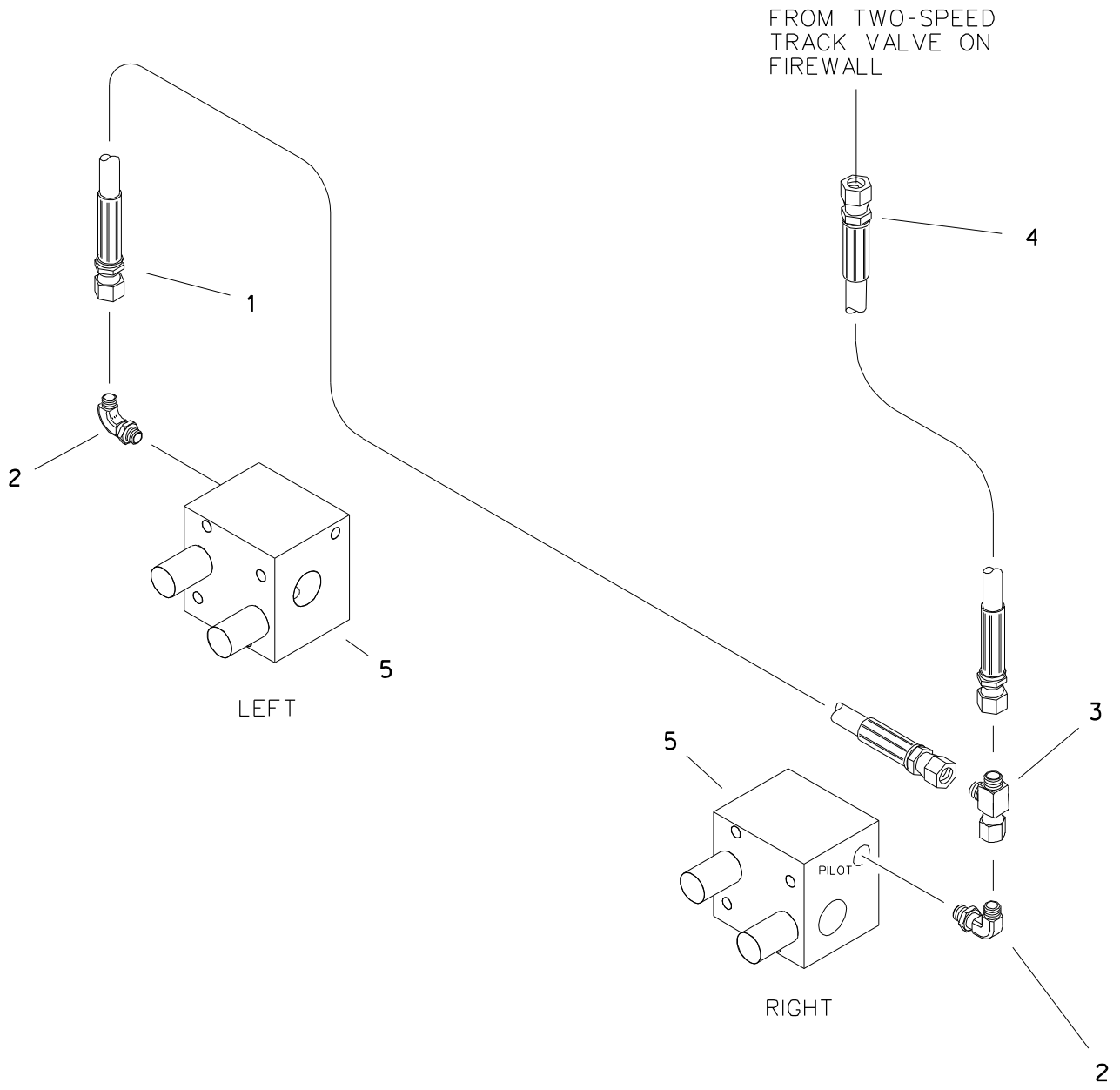

TRACK SHIFT

REF NO.	PART NUMBER	QTY	DESCRIPTION	REMARKS
1.	154-797	1	HOSE (060FX-48"-3000)	
2.	514-049	2	CONNECTOR (04S-06090)	
3.	154-344	1	UNION RUN TEE (060FX-060-060)	
4.	154-806	1	HOSE (060FX-54"-3000)	
5.	153-767	-	COUNTERBALANCE MANIFOLD	SERVICE CARTRIDGE

FOOTNOTES

NOTE

REFER TO O-RING CHART (800-301) IN BACK OF THE BOOK FOR REPLACEMENT OF O-RINGS.

TRACK BRAKE

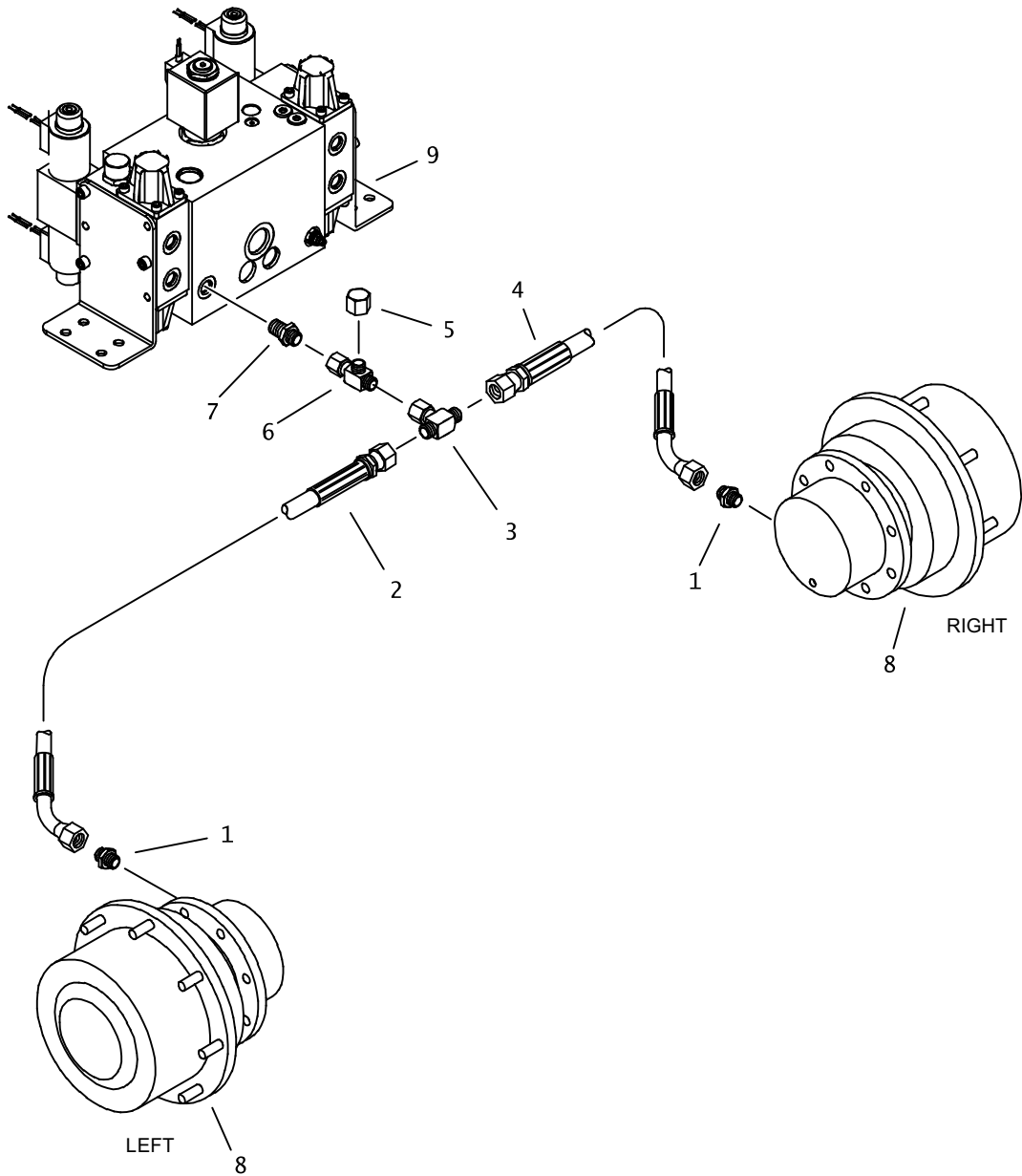

TRACK BRAKE

REF PART NO. NUMBER	QTY	DESCRIPTION	REMARKS
1. 154-411	2	CONNECTOR (04S-060)	
2. 515-188	1	HOSE (060FX90S-23"-3000)	
3. 154-348	1	UNION BR TEE (060FX-060-060)	
4. 154-738	1	HOSE (060FX90-34"-3000)	
5. 154-326	1	CAP (060F)	
6. 154-344	1	UNION RUN TEE (060FX-060-060)	
7. 154-221	1	CONNECTOR (06S-060)	
8. 166-285	2	PLANETARY GEARBOX	
		157-613 - INTERNAL SEAL	
		500-2029 - RETAINER RING, INTERNAL	
9. 153-639	-	HYD CONTROL VALVE	SEE FOOTNOTE 1

NOT SHOWN:

FOOTNOTES:

153-639 IS SUPERSEDED BY 150-1815

NOTE:

REFER TO O-RING CHART (800-301) IN BACK OF THE BOOK FOR REPLACEMENT OF O-RINGS.

FLUID CHECK SUPPLY HYDRAULICS

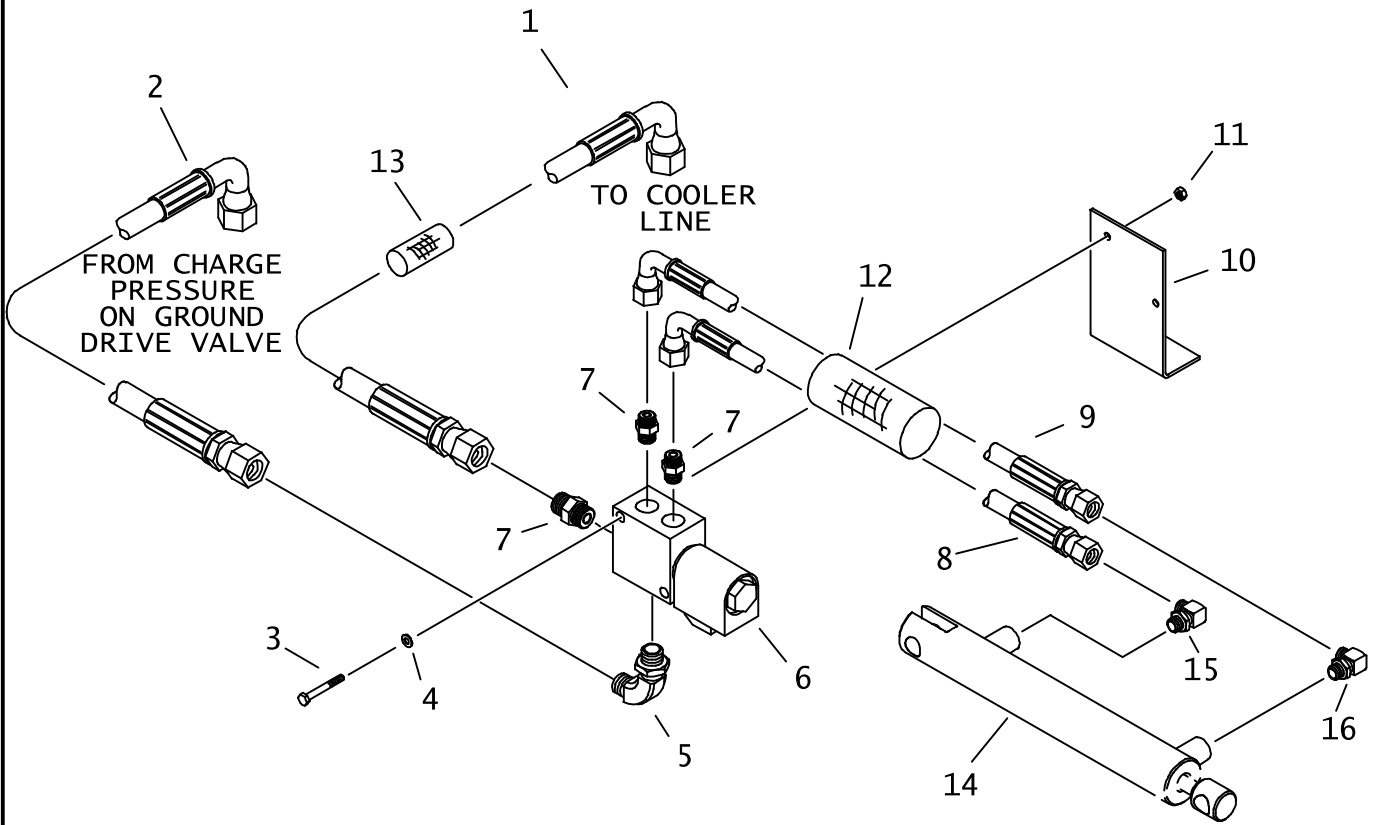

FLUID CHECK SUPPLY HYDRAULICS

REF NO.	PART NUMBER	QTY	DESCRIPTION	REMARKS
1.	515-696	1	HOSE (040FX90M-58"-3000)	
2.	515-583	1	HOSE (060FX90-12"-3000)	
3.	107-025	2	SCREW (M6-1.00 X 50MM)	
4.	105-095	2	WASHER (1/4")	
5.	154-342	1	CONNECTOR (06S-06090)	
6.	149-550	1	SOLENOID CONTROL VALVE	
	214-491	1	COIL (12V)	
7.	154-220	3	CONNECTOR (040-06S)	
8.	515-074	1	HOSE (040FX90-77"-3000)	
9.	154-982	1	HOSE (040FX90S-80"-3000)	
10.	310-637	1	VALVE BRACKET	
11.	106-538	1	LOCKNUT (M6-1.00,PRV TRQ,10.9)	
12.	115-963	1	ABRASION SLEEVE (1.59" X 75")	
13.	117-326	1	ABRASION SLEEVE (1.00" X 58")	
14.	150-727	-	CYL (1.0" X .500" X 4.0")	
15.	154-401	1	CONNECTOR (04S-04090, ORF)	
16.	154-252	1	CONNECTOR (04S-04090)	

NOT SHOWN:

FOOTNOTES:

NOTE:

REFER TO O-RING CHART (800-301) IN BACK OF THE BOOK FOR REPLACEMENT OF O-RINGS

THRUST/TRACK DRIVE PUMP HYDRAULICS

ENDS WITH S/N CMWA40T3C70000014

ENDS WITH S/N CMWJ40T3L70000025

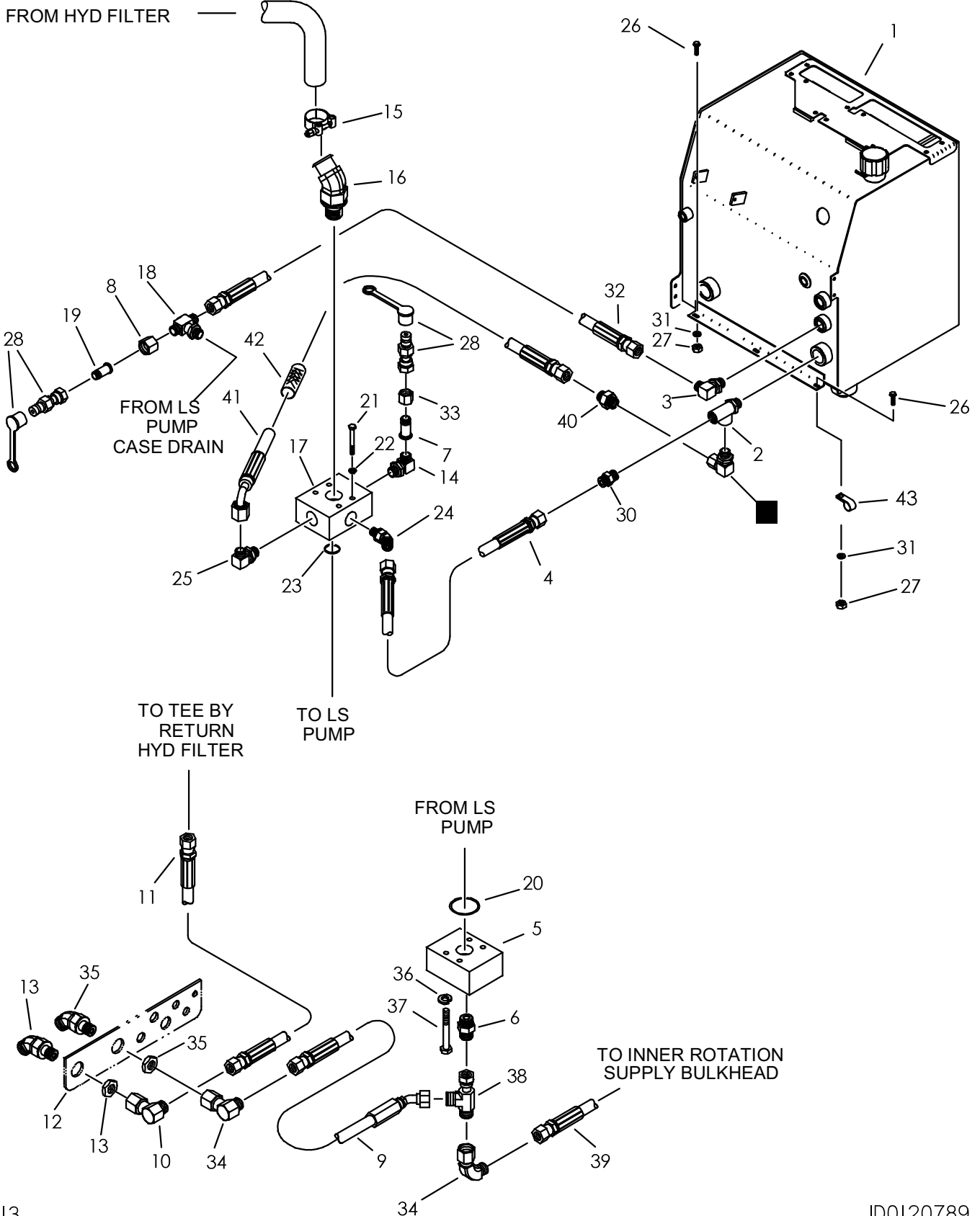

THRUST/TRACK DRIVE PUMP HYDRAULICS

ENDS WITH S/N CMWA40T3C70000014
ENDS WITH S/N CMWJ40T3L70000025

REF NO.	PART NUMBER	QTY	DESCRIPTION	REMARKS
1.	350-614	-	HYDRAULIC RESERVOIR	
2.	153-899	1	RUN TEE (20S-16SF-16SF)	
3.	154-377	1	CONNECTOR (12S-16090)	
4.	157-498	1	HOSE (160FX-22"-212)	
5.	153-393	1	MANIFOLD BLOCK	
6.	514-097	1	CONNECTOR (20S-200)	
7.	154-249	1	REDUCER STEM (080)	
8.	154-340	1	REDUCER NUT (160F)	
9.	157-754	1	HOSE (200FX45-27"-3000, SPEC)	
10.	154-290	1	UNION (160-160FX90)	
11.	154-815	1	HOSE (160FX-48"-4000)	
12.	350-740	-	BULKHEAD PLATE	
13.	514-242	1	BK CONNECTOR (160-16045BK)	
14.	514-010	1	CONNECTOR (120-20S90)	
15.	318-890	-	T-BLT CLP BRIDG 1.875-2.188	
16.	153-370	-	S/O COUPLER (24S-24H45)	
17.	153-892	1	PUMP INLET MANIFOLD	
18.	154-347	1	BRANCH TEE (16S-160-160)	
19.	154-341	1	REDUCER STEM (080)	
20.	157-128	1	O-RING (225 D90)	
21.	105-110	4	BOLT (1/2-NC X 4-1/2")	
22.	105-070	4	LOCK WASHER (.500")	
23.	157-015	1	O-RING (232 D70)	
24.	154-371	1	CONNECTOR (12S-16045)	
25.	514-196	1	CONNECTOR (160-2 S90)	
26.	106-381	6	FLG LK SCREW (M8-1.25 X 25MM)	
27.	106-561	6	LOCKNUT (M8-1.25, PRV TRQ, 10.9)	
28.	159-158	2	QDC ADAPTER (02-080FX)	
	159-148	-	DUST CAP (1/8")	
29.	153-908	1	UNION (16S-160FX90)	
30.	153-903	1	CHECK VALVE	
31.	105-118	6	WASHER (3/8")	
32.	157-755	1	HOSE (160FX-20"-212)	
33.	154-271	1	REDUCER NUT (120F)	
34.	514-422	2	CONNECTOR (200-200FX90)	AT ONLY
	514-177	-	CAP (200F)	JT ONLY
35.	153-395	1	BK CONNECTOR (200-20045)	
36.	105-385	4	LOCK WASHER (5/8")	
37.	105-943	4	BOLT (5/8-NC X 2-3/4")	
38.	514-142	1	UN RUN TEE (200FX-200-200)	
39.	157-753	1	HOSE (200FX-26"-3000, SPEC)	AT ONLY
40.	153-904	1	CHECK VALVE	
41.	153-938	1	HOSE (160FX90S-30"-200)	
42.	117-296	1	ABRASION SLEEVE (2.07" X 30")	
43.	110-333	1	BOLT-ON CLAMP (1")	

NOT SHOWN:

FOOTNOTES:

NOTE:

1. REFER TO O-RING CHART (800-301) IN BACK OF THE BOOK FOR REPLACEMENT OF O-RINGS.

LOAD SENSE HYDRAULICS

ENDS WITH S/N CMWJ40T3P70000019

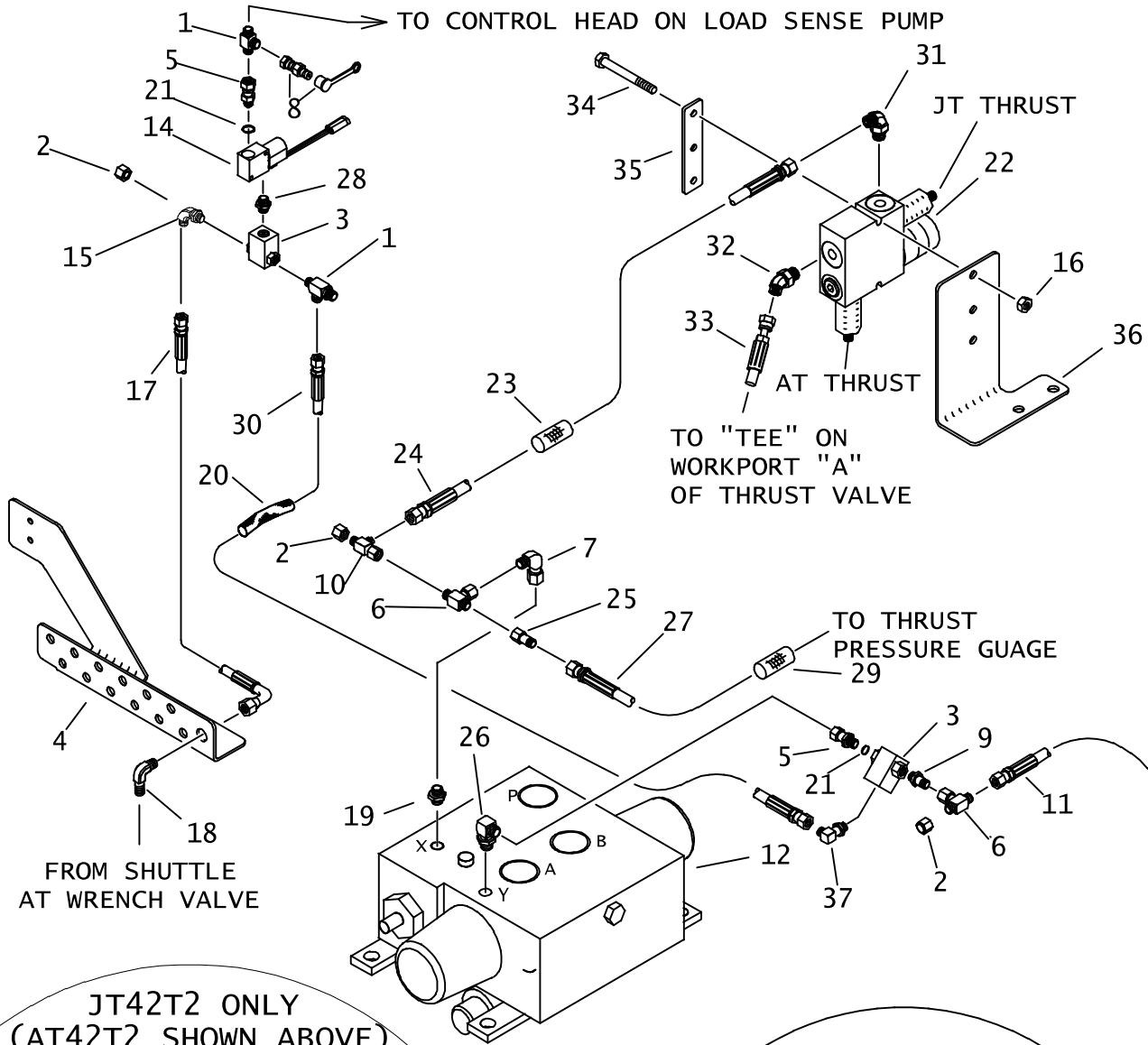

JT42T2 ONLY
(AT42T2 SHOWN ABOVE)

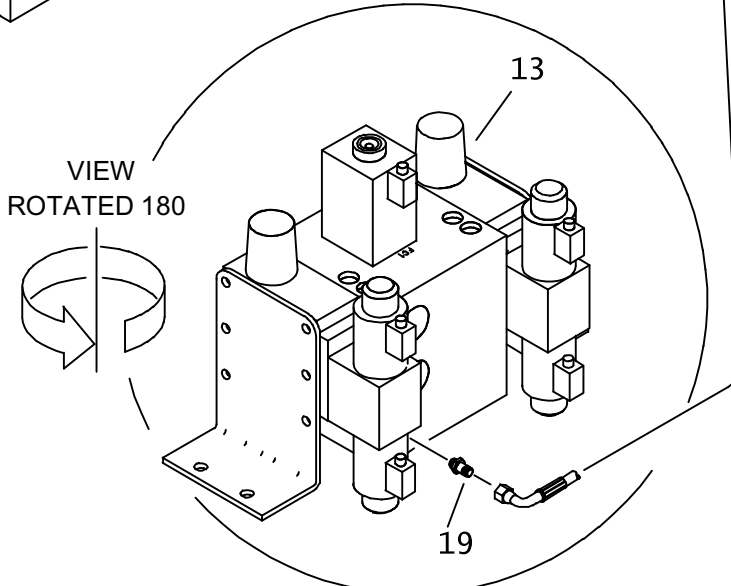
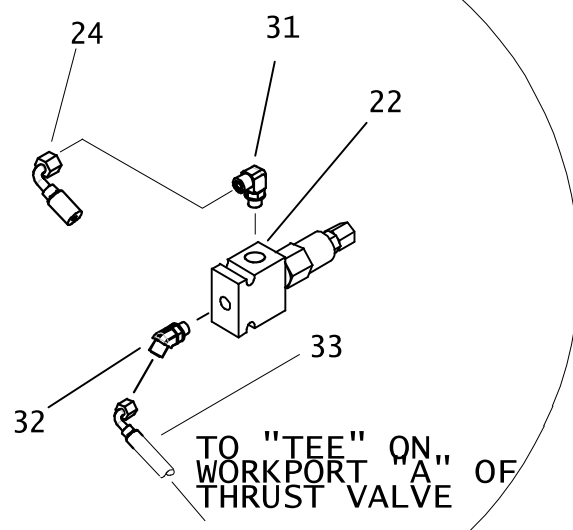

LOAD SENSE HYDRAULICS

ENDS WITH S/N CMWJ40T3P70000019

REF NO.	PART NUMBER	QTY	DESCRIPTION	REMARKS
1.	154-345	2	RUN TEE (06S-060-060)	
2.	154-326	3	CAP (060F)	
3.	158-600	2	HYD SHUTTLE VALVE	NOT SERVICABLE PER SUPPLIER
4.	354-466	-	BULKHEAD PLATE	
5.	514-409	2	UNION (06J-060FX)	
6.	154-348	2	UNION BR TEE (060FX-060-060)	
7.	154-228	1	CONNECTOR (060-060FX90)	
8.	159-157	1	QDC ADAPTER (02-060F)	
	159-148	-	DUST CAP (1/8")	
9.	154-221	1	CONNECTOR (06S-060)	
10.	154-344	1	UNION RUN TEE (060FX-060-060)	
11.	149-559	1	HOSE (060FX90M-20"-3000)	
12.	157-440	-	THRUST VALVE (ELECTRIC)	SEE FOOTNOTE 4
	150-1458	-	THRUST VALVE (ELECTRIC)	SEE FOOTNOTE 5
	500-1290	-	THRUST VALVE COIL	
13.	153-639	-	HYD CONTROL VALVE	SEE FOOTNOTE 6
	217-897		SOLENOID COIL (LARGE)	
	214-434		SOLENOID COIL (SMALL)	
	149-565		3-WAY CARTRIDGE VALVE	
	150-1525		PROPORTIONAL VALVE	
	150-2032		PRESSURE COMPENSATOR VALVE	
	150-2033		SEAL KIT	
14.	158-661	1	HYD CONTROL VALVE	
	500-757	-	SEAL REPAIR KIT	
	214-491	-	COIL, 12V	
15.	154-342	1	CONNECTOR (06S-06090)	
16.	106-237	2	LOCKNUT (M6-1.00, PRV TRQ, NLK)	
17.	154-738	1	HOSE (060FX90-34"-3000)	
18.	154-229	1	BK CONNECTOR (060-06090BK)	
19.	154-411	2	CONNECTOR (04S-060)	
20.	117-702	1	ABRASION SLEEVE (1.00" X 68")	
21.	155-705	2	O-RING (906 D90)	
22.	153-328	1	HYDRAULIC VALVE	SEE FOOTNOTE 3, AT ONLY
	516-121	1	VALVE	JT ONLY
	155-074	-	PLUG (08S, SOC, FM)	SEE FOOTNOTE 2
23.	117-411	1	ABRASION SLEEVE (1.00" X 32")	
24.	153-305	1	HOSE (060FX-31"-3000)	AT ONLY
	515-188	1	HOSE (060FX90S-23"-3000)	JT ONLY
25.	154-373	1	REDUCER (040-060F)	

NOT SHOWN:

FOOTNOTES:

1. VALVE MOUNT BRACKET BOLTS DOWN TO FRAME ALONG WITH GROUND DRIVE VALVE BRACKET HARDWARE.
2. TORQUE FACTORY PLUG (NO O-RING) TO 24 LB-FT.
TORQUE SERVICE PLUG (WITH O-RING) TO 72 LB-FT.
3. THE PLUG THAT COMES INSTALLED IN THE VALVE MAY HAVE TO BE MOVED TO THE "A" PORT.
4. ENDS WITH S/N: CMWJ42T2J60000023; CMWA42T2E60000029; CMWA40T3P60000002; CMWJ40T3T60000001.
5. BEGINS WITH S/N: CMWA40T3K60000003; CMWJ40T3P60000002.
6. 153-639 HYD CONTROL VALVE IS SUPERSEDED BY 150-1815 HYD CONTROL VALVE.

NOTE:

LOAD SENSE HYDRAULICS

ENDS WITH S/N CMWJ40T3P70000019

REF NO.	PART NUMBER	QTY	DESCRIPTION	REMARKS
26.	514-049	1	CONNECTOR (04S-06090)	
27.	515-161	1	HOSE (040FX-160"-3000)	
28.	155-153	1	CONNECTOR (06S-06S)	
29.	117-759	1	ABRASION SLEEVE (1.00" X 160")	
30.	154-808	1	HOSE (060FX-74"-3000)	
31.	154-227	1	CONNECTOR (060-08S90)	AT ONLY
	154-342	1	CONNECTOR (06S-06090)	JT ONLY
32.	154-225	1	CONNECTOR (060-08S45)	AT ONLY
	154-224	1	CONNECTOR (06S-06045)	JT ONLY
33.	515-538	1	HOSE (060FX90S-15"-3000)	NOTE HOSE ORIENTATION DIFFERENCE BETWEEN AT & JT
34.	106-893	2	SCREW (M6-1.00 X 55MM)	
35.	310-400	1	BACKUP PLATE	
36.	314-459	1	PLATE	SEE FOOTNOTE 1
37.	157-420	1	CONN (06S-06090,ORF .028)	

NOT SHOWN:

FOOTNOTES:

NOTE:

LOAD SENSE HYDRAULICS

BEGINS WITH S/N CMWJ40T3P7000020

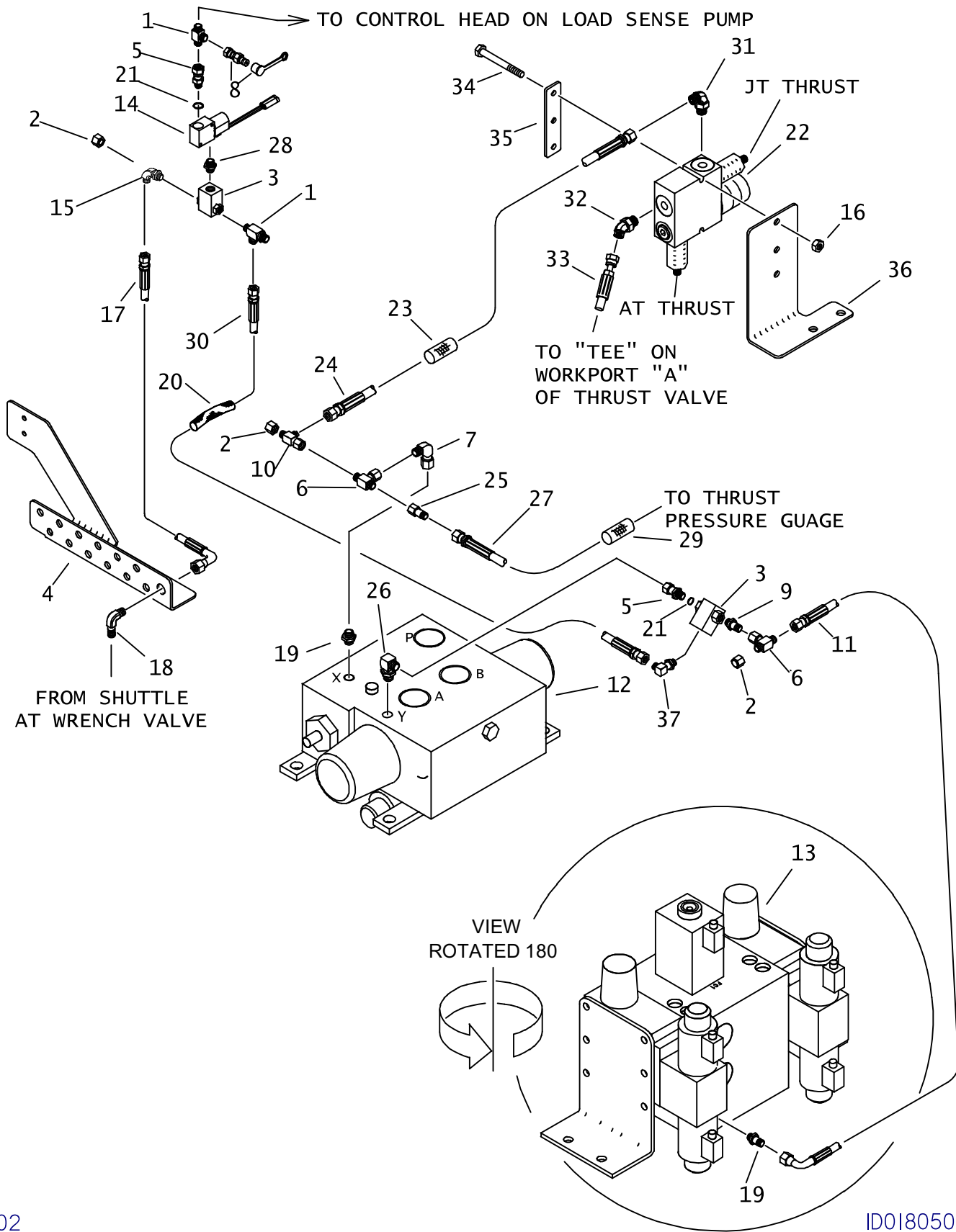

LOAD SENSE HYDRAULICS

BEGINS WITH S/N CMWJ40T3P70000020

REF NO.	PART NUMBER	QTY	DESCRIPTION	REMARKS
1.	154-345	2	RUN TEE (06S-060-060)	
2.	154-326	3	CAP (060F)	
3.	158-600	2	HYD SHUTTLE VALVE	NOT SERVICABLE PER SUPPLIER
4.	354-466	-	BULKHEAD PLATE	
5.	514-409	2	UNION (06J-060FX)	
6.	154-348	2	UNION BR TEE (060FX-060-060)	
7.	154-228	1	CONNECTOR (060-060FX90)	
8.	159-157	1	QDC ADAPTER (02-060F)	
	159-148	-	DUST CAP (1/8")	
9.	154-221	1	CONNECTOR (06S-060)	
10.	154-344	1	UNION RUN TEE (060FX-060-060)	
11.	149-559	1	HOSE (060FX90M-20"-3000)	
12.	157-440	-	THRUST VALVE (ELECTRIC)	SEE FOOTNOTE 3
	150-1458	-	THRUST VALVE (ELECTRIC)	SEE FOOTNOTE 4
	500-1290	-	THRUST VALVE COIL	
13.	153-639	-	HYD CONTROL VALVE	SEE FOOTNOTE 5
	217-897		SOLENOID COIL (LARGE)	
	214-434		SOLENOID COIL (SMALL)	
	149-565		3-WAY CARTRIDGE VALVE	
	150-1525		PROPORTIONAL VALVE	
	150-2032		PRESSURE COMPENSATOR VALVE	
	150-2033		SEAL KIT	
14.	158-661	1	HYD CONTROL VALVE	
	500-757	-	SEAL REPAIR KIT	
	214-491	-	COIL, 12V	
15.	154-342	1	CONNECTOR (06S-06090)	
16.	106-237	2	LOCKNUT (M6-1.00, PRV TRQ, NLK)	
17.	154-738	1	HOSE (060FX90-34"-3000)	
18.	154-229	1	BK CONNECTOR (060-06090BK)	
19.	154-411	2	CONNECTOR (04S-060)	
20.	117-702	1	ABRASION SLEEVE (1.00" X 68")	
21.	155-705	2	O-RING (906 D90)	
22.	153-328	1	HYDRAULIC VALVE	SEE FOOTNOTE 2
23.	117-411	1	ABRASION SLEEVE (1.00" X 32")	
24.	153-305	1	HOSE (060FX-31"-3000)	
25.	154-373	1	REDUCER (040-060F)	

NOT SHOWN:

FOOTNOTES:

1. VALVE MOUNT BRACKET BOLTS DOWN TO FRAME ALONG WITH GROUND DRIVE VALVE BRACKET HARDWARE.
2. AT THRUST RELIEF ADJUSTMENT MUST BE SCREWED IN COMPLETELY FOR JT MACHINES TO OPERATE PROPERLY.
3. ENDS WITH S/N: CMWJ42T2J60000023; CMWA42T2E60000029; CMWA40T3P60000002; CMWJ40T3T60000001.
4. BEGINS WITH S/N: CMWA40T3K60000003; CMWJ40T3P60000002.
5. 153-639 HYD CONTROL VALVE IS SUPERSEDED BY 150-1815 HYD CONTROL VALVE.

NOTE:

LOAD SENSE HYDRAULICS

BEGINS WITH S/N CMWJ40T3P70000020

REF NO.	PART NUMBER	QTY	DESCRIPTION	REMARKS
26.	514-049	1	CONNECTOR (04S-06090)	
27.	515-161	1	HOSE (040FX-160"-3000)	
28.	155-153	1	CONNECTOR (06S-06S)	
29.	117-759	1	ABRASION SLEEVE (1.00" X 160")	
30.	154-808	1	HOSE (060FX-74"-3000)	
31.	154-227	1	CONNECTOR (060-08S90)	
32.	154-225	1	CONNECTOR (060-08S45)	
33.	515-538	1	HOSE (060FX90S-15"-3000)	
34.	106-893	2	SCREW (M6-1.00 X 55MM)	
35.	310-400	1	BACKUP PLATE	
36.	314-459	1	PLATE	SEE FOOTNOTE 1
37.	157-420	1	CONN (06S-06090,ORF .028)	

NOT SHOWN:

FOOTNOTES:

NOTE:

LOAD SENSE REAR HYDRAULICS

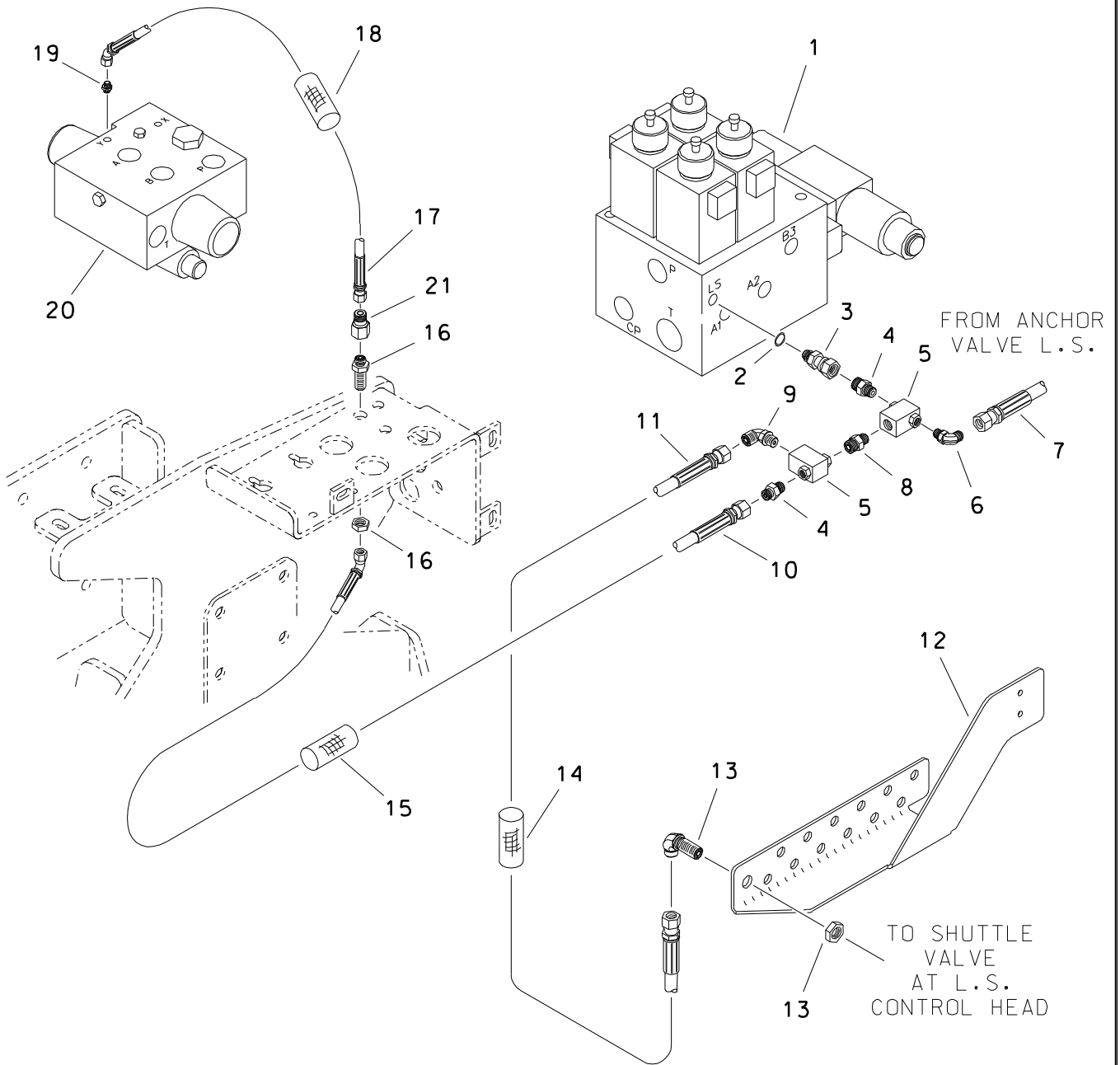

LOAD SENSE REAR HYDRAULICS

REF NO.	PART NUMBER	QTY	DESCRIPTION	REMARKS
1.	153-410	-	HYDRAULIC VALVE	
2.	155-705	1	O-RING (906 D90)	
3.	514-409	1	UNION (06J-06DFX)	
4.	154-221	2	CONNECTOR (06S-060)	SEE FOOTNOTE 1
5.	158-600	2	HYD SHUTTLE VALVE	ONE ONLY FOR JT
6.	154-342	1	CONNECTOR (06S-06090)	
7.	515-410	-	HOSE (06DFX45-118"-3000)	
8.	155-153	1	CONNECTOR (06S-06S)	AT ONLY
9.	157-420	1	CONN (06S-06090, ORF .028)	AT ONLY
10.	157-288	1	HOSE (06DFX45-238"-3000)	AT ONLY
11.	154-816	1	HOSE (06DFX-120"-3000)	
12.	354-466	-	BULKHEAD PLATE	
13.	154-229	-	BK CONNECTOR (060-06090BK)	
14.	117-212	1	ABRASION SLEEVE (1.25" X 118")	
15.	117-400	1	ABRASION SLEEVE (1.00" X 72")	AT ONLY
16.	514-163	1	BK CONNECTOR (060-060BK)	AT ONLY
17.	153-073	1	HOSE (04DFX45-28"-3000)	AT ONLY
18.	117-409	1	ABRASION SLEEVE (1.00" X 28")	AT ONLY
19.	157-286	1	CONNECTOR (04S-040, ORF .028)	AT ONLY
20.	153-773	-	HYDRAULIC VALVE	AT ONLY
21.	154-373	1	REDUCER (040-06DF)	AT ONLY

FOOTNOTES

1. REPLACED BY 510-015 1X FOR JT4020 MACH 1

NOTES

REFER TO O-RING CHART (800-301) ON BACK OF THE BOOK FOR REPLACEMENT OF O-RINGS.

INNER ROTATION HYDRAULICS

JT4020 ALL TERRAIN ONLY

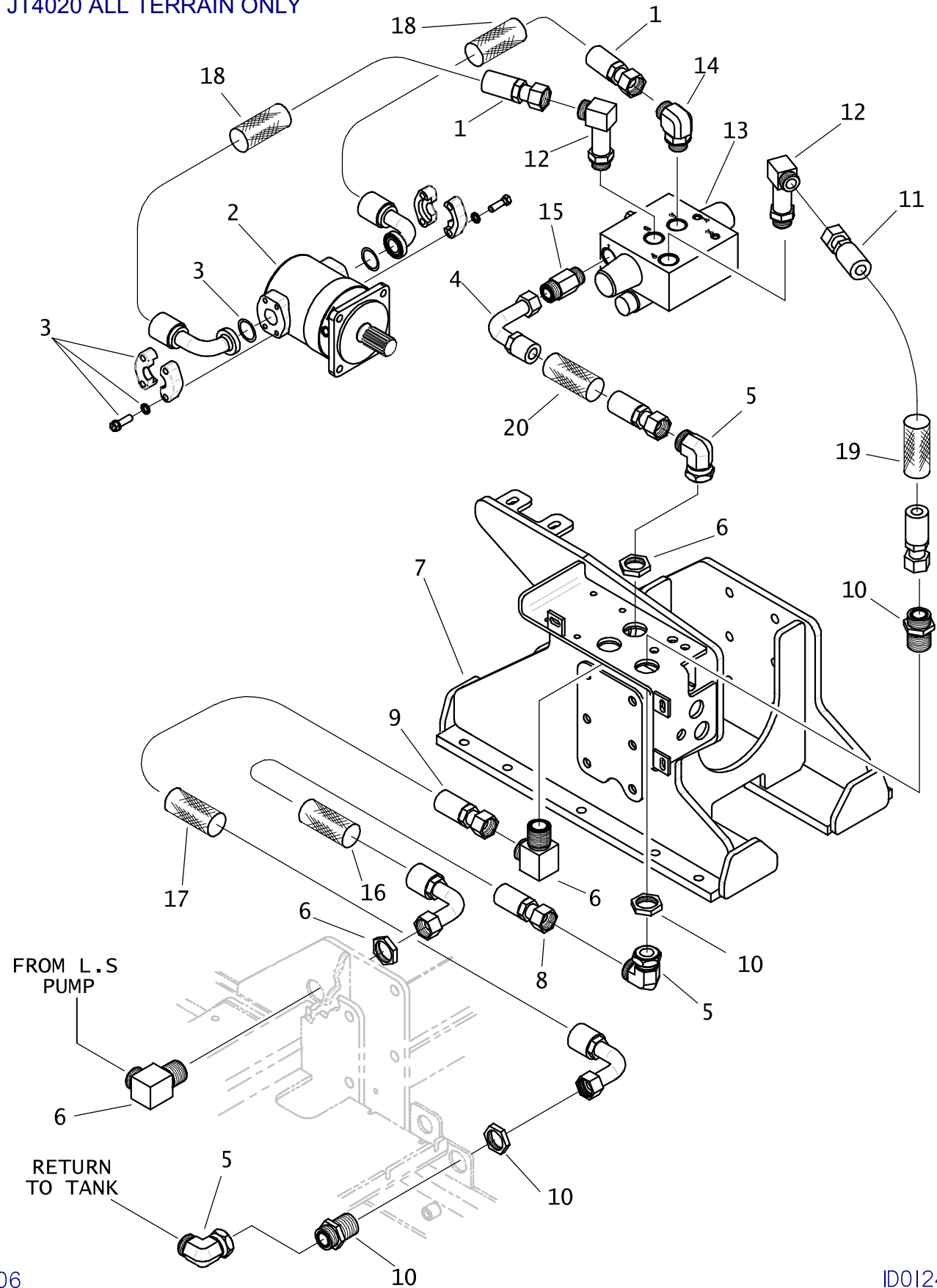

INNER ROTATION HYDRAULICS

JT4020 ALL TERRAIN ONLY

REF NO.	PART NUMBER	QTY	DESCRIPTION	REMARKS
1.	153-663	2	HOSE (160FX-20FL90S-36.5-3000)	USE 1 @ 74"
2.	153-612	-	HYDRAULIC MOTOR	
	191-263	-	SEAL REPAIR KIT	
3.	159-036	2	SPLIT FLANGE (20F, SET)	
4.	153-665	1	HOSE (160FX90L-200FX-15"-3000)	
5.	514-422	3	CONNECTOR (200-200FX90)	
6.	153-679	2	SP CONNECTOR (200-20090BK)	
7.	313-958	-	CARRIAGE	
8.	157-752	1	HOSE (200FX90S-217"-3000, SPEC)	
9.	153-746	1	HOSE (200F90L-230"-3000)	
10.	514-096	2	BK CONNECTOR (200-200BK)	
11.	153-664	1	HOSE (160FX-200FX45-20.5-3000)	
12.	154-289	2	CONNECTOR (16S-16090,XL)	
13.	153-773	-	HYDRAULIC VALVE	
14.	154-287	1	CONNECTOR (16S-16090)	
15.	154-398	1	CONNECTOR (16S-160,XLG)	
16.	115-894	1	ABRASION SLEEVE (2.38" X 60")	
17.	117-705	1	ABRASION SLEEVE (2.38" X 78")	
18.	115-731	2	ABRASION SLEEVE (2.38" X 34")	
19.	117-565	1	ABRASION SLEEVE (1.75" X 19")	
20.	117-564	1	ABRASION SLEEVE (1.75" X 15")	

NOT SHOWN:

FOOTNOTES:

NOTE:

INNER ROTATION CONTROL KIT

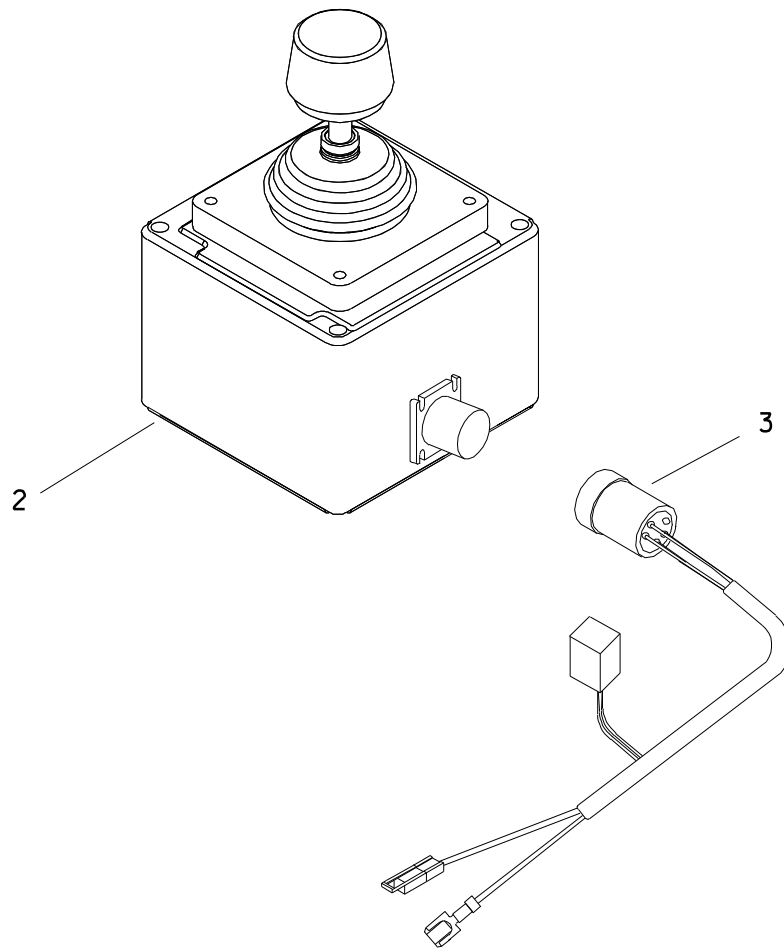

INNER ROTATION CONTROL KIT

REF NO.	PART NUMBER	QTY	DESCRIPTION	REMARKS
	101-155	-	INNER ROTATION CONTROL KIT	CONTAINS REF NO. 1-3
1.	051-346	1	INNER ROT JOYSTICK KIT INSTR	NOT SHOWN
2.	101-156	1	SPINDLE CONTROL BOX	
3.	213-099	1	INNER ROTATION HARNESS	
	217-710	-	MICRO RELAY (SPDT)	NOT SHOWN

FOOTNOTES

THRUST HYDRAULICS

JT4020 ALL TERRAIN

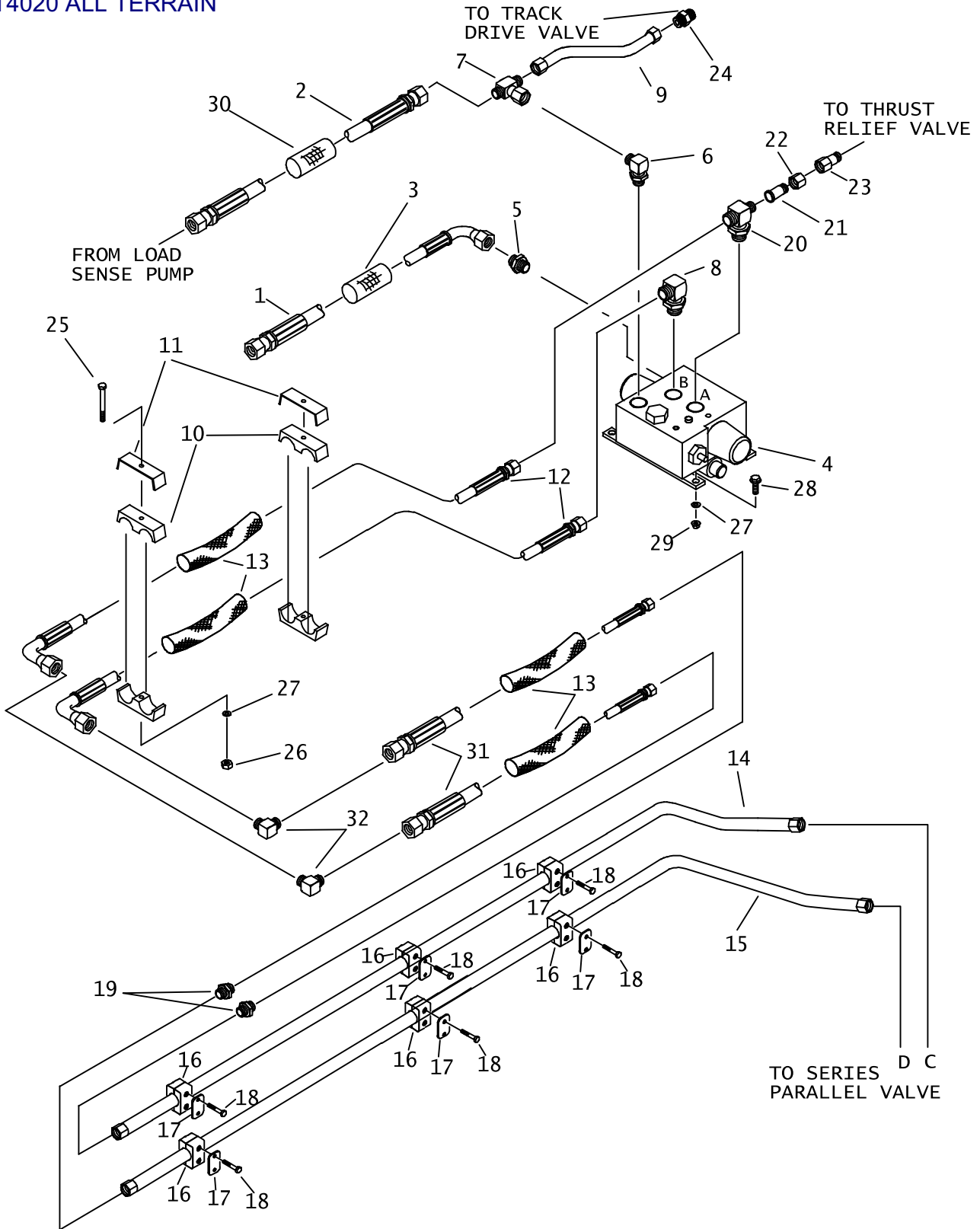

THRUST HYDRAULICS

JT4020 ALL TERRAIN

REF NO.	PART NUMBER	QTY	DESCRIPTION	REMARKS
1.	515-655	1	HOSE (160FX90-47"-3000)	
2.	157-499	1	HOSE (200FX-47"-3000, SPECIAL)	
3.	115-715	1	ABRASION SLEEVE (2.07" X 42")	
4.	157-440	-	THRUST VALVE (ELECTRIC)	SEE FOOTNOTE 1
	150-1458	-	THRUST VALVE (ELECTRIC)	SEE FOOTNOTE 2
	500-1290	-	THRUST VALVE COIL	
5.	154-398	1	CONNECTOR (16S-160, XLG)	
6.	154-287	1	CONNECTOR (16S-16090)	
7.	153-391	1	TEE (-200-160-160FX)	
8.	154-289	1	CONNECTOR (16S-16090, XL)	
9.	156-896	1	HYD LINE (160FX-4.7")	
10.	110-359	2	BOLT-ON CLAMP (1-1/2", SET)	
11.	315-623	2	BACKUP SPACER	
12.	515-656	2	HOSE (160FX90-55"-3000)	
	149-045	1	HYD LINE (-16)	
	149-046	1	HYD LINE (-16)	
13.	117-289	4	ABRASION SLEEVE (2.07" X 55")	
14.	149-296	1	HYD LINE (-16)	
15.	149-295	1	HYD LINE (-16)	
16.	110-573	6	BOLT-ON CLAMP (1", PER SET)	
17.	322-289	6	BACKUP (BOLT-ON)	
18.	105-818	12	BOLT (1/4-NC X 1-1/2")	
19.	154-439	2	CONNECTOR (160-160)	
20.	154-347	1	BRANCH TEE (16S-160-160)	
21.	154-341	1	REDUCER STEM (080)	
22.	154-340	1	REDUCER NUT (160F)	
23.	154-262	1	REDUCER (060-080F)	
24.	154-281	1	CONNECTOR (16S-160)	
25.	106-602	2	SCREW (M8-1.25 X 80MM)	
26.	106-561	2	LOCKNUT (M8-1.25, PRV TRQ, 10.9)	
27.	106-396	10	WASHER (M10, HARDENED)	
28.	106-079	8	SCREW (M10-1.50 X 30MM)	
29.	105-894	8	LOCKNUT (M10-1.50, PRV TRQ, 10.9)	
30.	117-668	1	ABRASION SLEEVE (2.38" X 42")	
31.	157-845	2	HOSE (160FX-53.5"-3000)	
32.	514-009	2	CONNECTOR (160-16090)	

NOT SHOWN:

FOOTNOTES:

- ENDS WITH S/N: CMWJ42T2J60000023; CMWA42T2E60000029; CMWA40T3P60000002; CMWJ40T3T60000001
- BEGINS WITH S/N: CMWA40T3K60000003; CMWJ40T3P60000002

NOTE:

REFER TO O-RING CHART (800-301) IN BACK OF THE BOOK FOR THE REPLACEMENT OF O-RINGS.

THRUST DRIVE HYDRAULICS

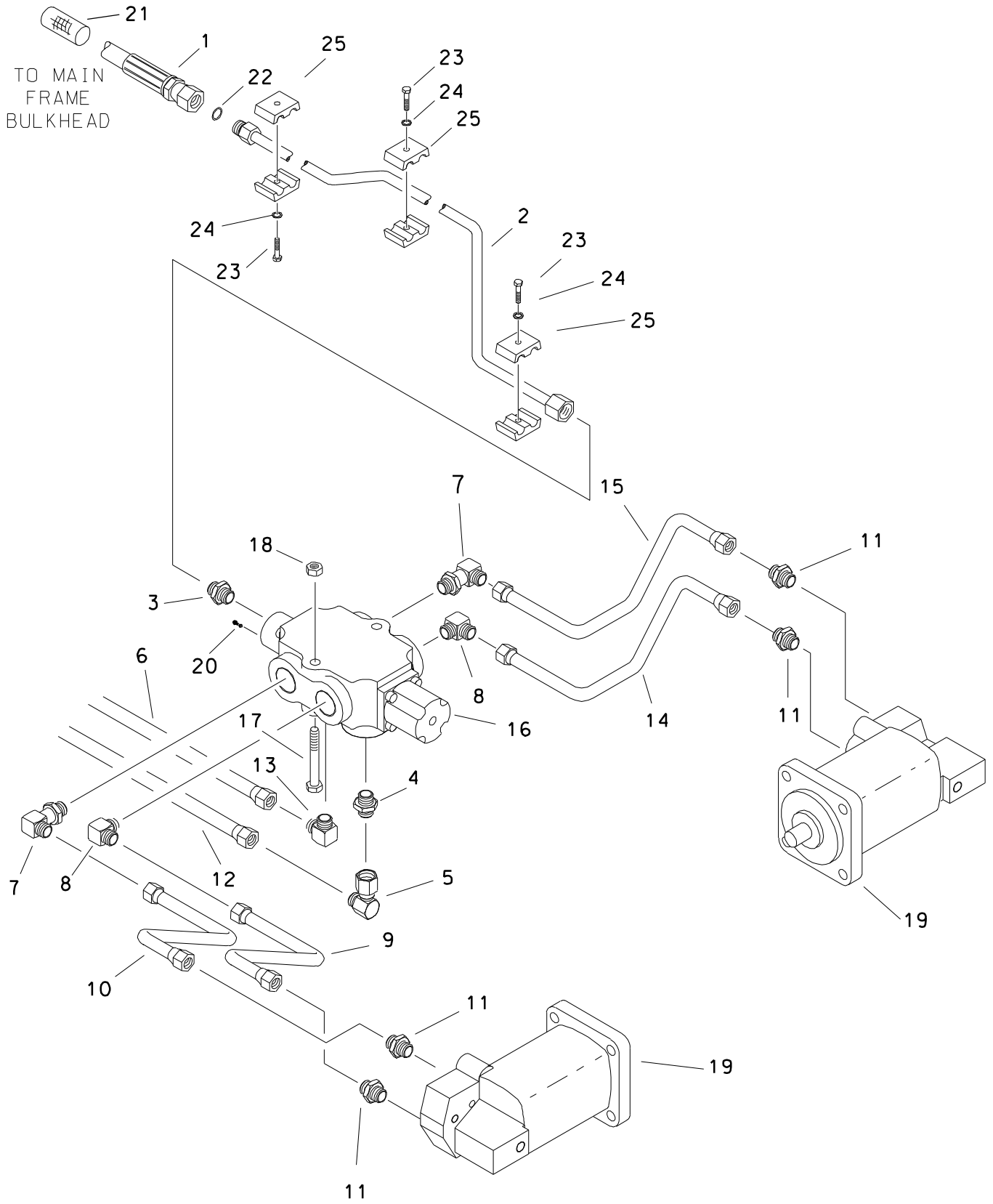

THRUST DRIVE HYDRAULICS

REF NO.	PART NUMBER	QTY	DESCRIPTION	REMARKS
1.	154-651	1	HOSE (040FX-66"-3000)	
2.	153-040	1	HYD LINE	
3.	154-411	1	CONNECTOR (04S-060)	
4.	154-281	1	CONNECTOR (16S-160)	
5.	154-290	1	UNION (160-160FX90)	
6.	149-296	-	HYD LINE (-16)	
7.	154-338	2	CONNECTOR (12S-12090, XL)	
8.	154-270	2	CONNECTOR (12S-12090)	
9.	156-886	1	HYD LINE (-12)	
10.	156-885	1	HYD LINE (-12)	
11.	154-269	4	CONNECTOR (12S-120)	
12.	149-295	-	HYD LINE (-16)	
13.	154-287	1	CONNECTOR (16S-16090)	
14.	156-884	1	HYD LINE (-12)	
15.	156-883	1	HYD LINE (-12)	
16.	149-343	1	HYDRAULIC CONTROL VALVE	
	190-863		SEAL REPAIR KIT	
	500-698		END CAP	NOT DRILLED/TAPPED
	310-800		END CAP	DRILLED/TAPPED
17.	106-570	2	SCREW (M8-1.25 X 60mm)	
18.	106-561	2	LOCKNUT (M8-1.25, PRV TRQ, 10.9)	
19.	158-026	2	HYD MOTOR (15 CU/IN)	
20.	163-101	1	BLEEDER VALVE	
21.	117-613	1	ABRASION SLEEVE (1.00" X 64")	
22.	157-037	1	O-RING (011 D90)	
23.	105-197	3	BOLT (1/4-NC X 1")	
24.	105-117	3	WASHER (5/16")	
25.	110-998	3	CLAMP HALVES (3/8") PAIR	

FOOTNOTES

NOTE
REFER TO O-RING CHART (800-301) IN BACK OF THE BOOK FOR REPLACEMENT OF O-RINGS.

FLUID MOTOR HYDRAULICS

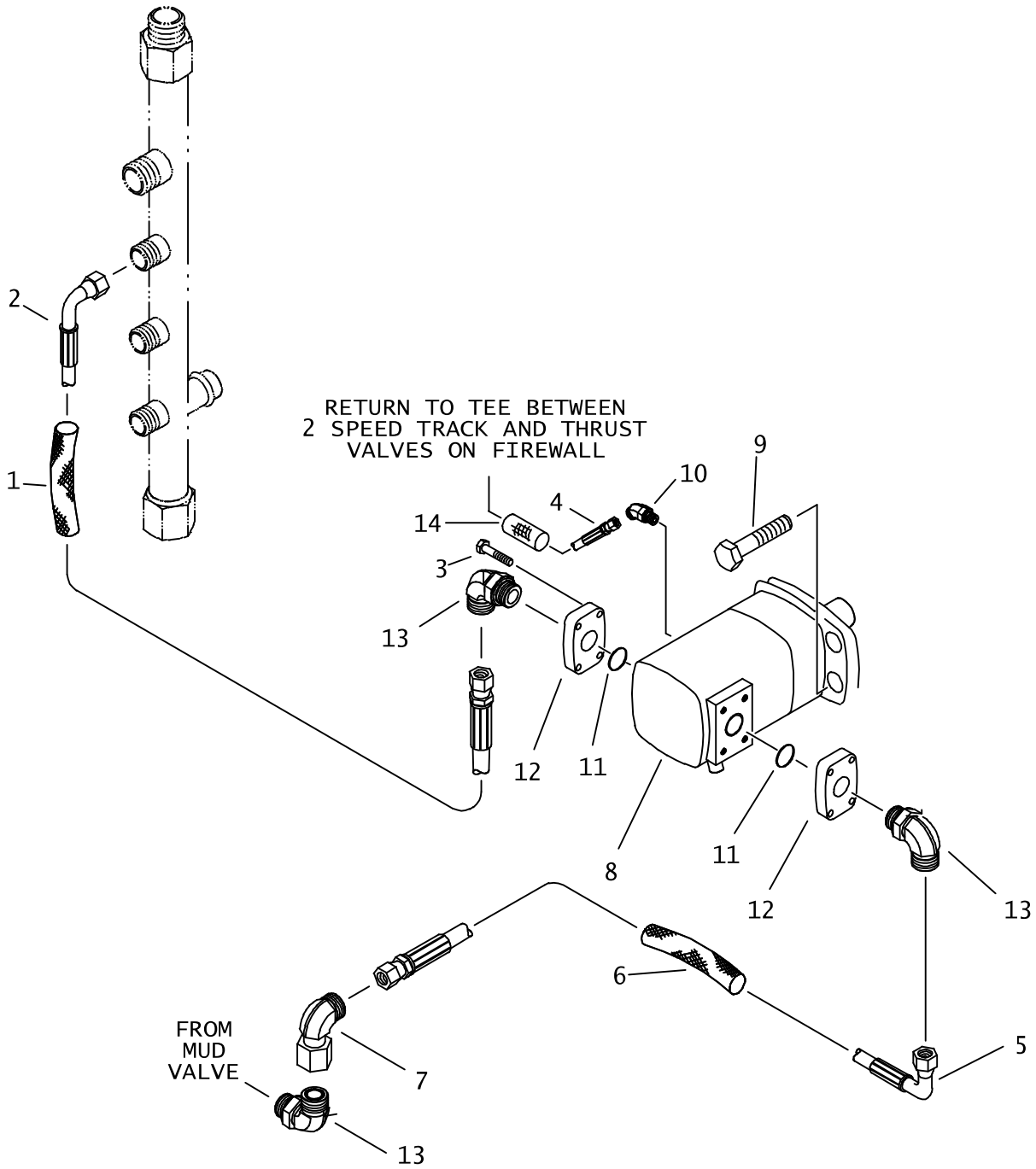

FLUID MOTOR HYDRAULICS

REF NO.	PART NUMBER	QTY	DESCRIPTION	REMARKS
1.	117-097	1	ABRASION SLEEVE (2.07" X 80")	
2.	157-284	1	HOSE (160FX90S-84"-3000)	
3.	105-918	8	BOLT (7/16-NC X 1-1/2", SOC)	
4.	154-789	1	HOSE (060FX-102"-3000)	
5.	153-432	1	HOSE (160FX90S-64"-3000)	
6.	117-179	1	ABRASION SLEEVE (2.07" X 62")	
7.	154-290	1	UNION (160-160FX90)	
8.	149-395	1	HYDRAULIC MOTOR	SEE FOOTNOTE 2
	158-013	1	HYDRAULIC MOTOR	SEE FOOTNOTE 1
	500-1532	AR	SEAL REPAIR KIT	
9.	105-282	4	BOLT (1/2-NC X 1-1/4", SOC)	
10.	154-224	1	CONNECTOR (06S-06045)	
11.	157-078	2	O-RING (222 D90)	
12.	149-084	2	HEAD FLANGE (20FL-16SF)	
13.	154-287	3	CONNECTOR (16S-16090)	
14.	117-213	1	ABRASION SLEEVE (1.00" X 96")	

NOT SHOWN:

FOOTNOTES:

1. USED WITH 158-434 (70 GPM MUD PUMP)
2. USED WITH 149-396 (120 GPM MUD PUMP)

NOTE

REFER TO O-RING CHART (800-301) IN BACK OF THE BOOK FOR REPLACEMENT OF O-RINGS.

NOTE:

TRACK DRIVE HYDRAULICS

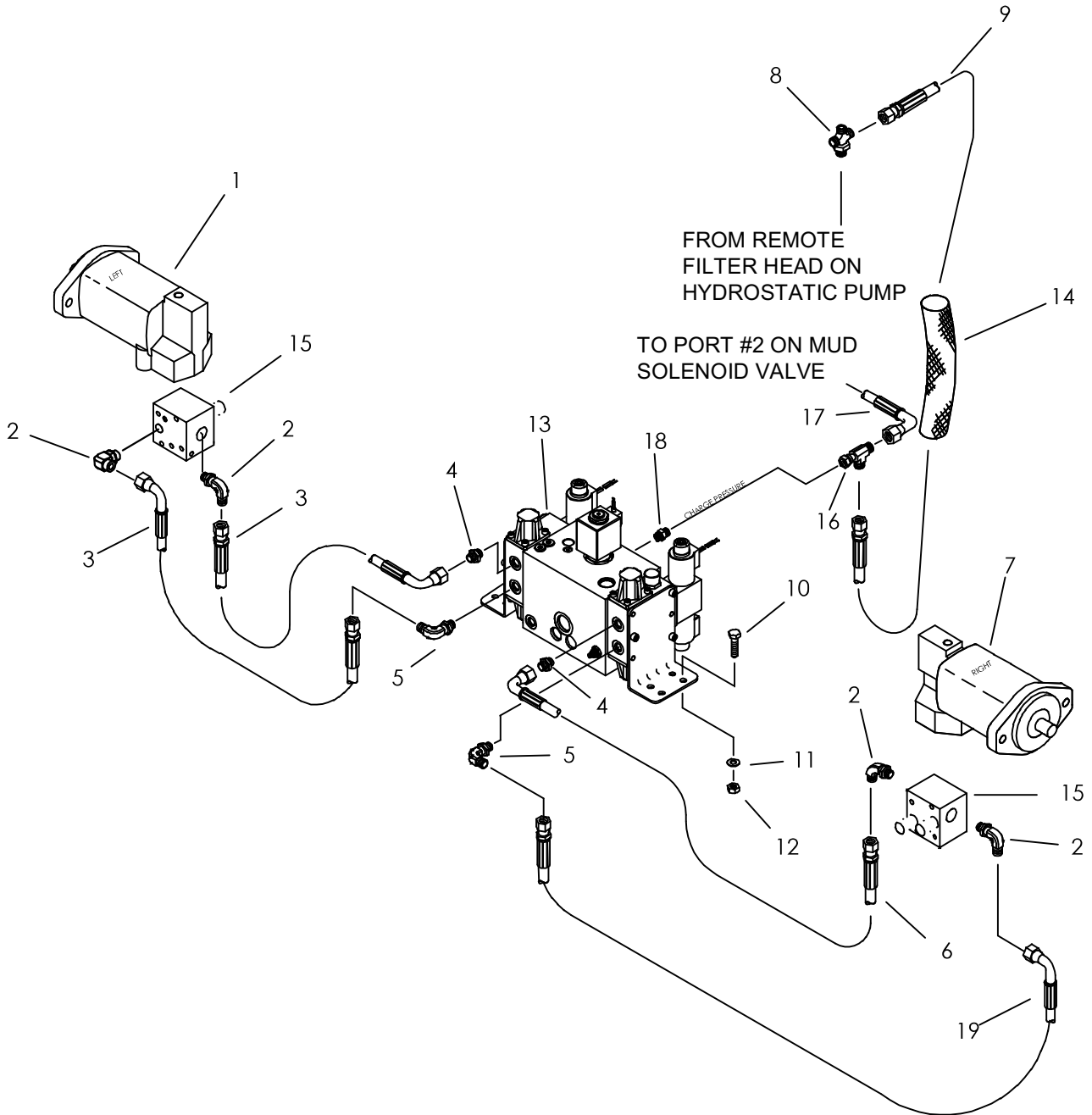

TRACK DRIVE HYDRAULICS

REF NO.	PART NUMBER	QTY	DESCRIPTION	REMARKS
1.	153-593	1	HYDRAULIC MOTOR	LEFT TRACK
2.	154-270	4	CONNECTOR (12S-12090)	
3.	153-758	2	HOSE (120FX90S-14"-3000)	
4.	154-247	2	CONNECTOR (10S-120)	
5.	154-273	2	CONNECTOR (10S-12090)	
6.	153-759	1	HOSE (120FX90M-16"-3000)	
7.	153-592	1	HYDRAULIC MOTOR	RIGHT TRACK, USE SEAL KIT 500-752
8.	149-847	-	CROSS (06S-060-060-080)	
9.	154-757	1	HOSE (060FX-86"-3000)	
10.	106-079	4	SCREW (M10-1.50 X 30mm)	
11.	106-396	4	WASHER (M10, HARDENED)	
12.	105-894	4	LOCKNUT (M10-1.50, PRV TRQ, 10.9)	
13.	153-639	1	HYD CONTROL VALVE	SEE FOOTNOTE 1
14.	117-398	1	ABRASION SLEEVE (1.00" X 86")	
15.	153-767	2	COUNTERBALANCE MANIFOLD	
16.	154-344	1	UN RUN TEE (060FX-060-060)	
17.	515-583	-	HOSE (060FX90-12"-3000)	
18.	156-174	1	CONNECTOR (06S-060)	BACK PORT (NOT SHOWN)
19.	153-928	1	HOSE (120FX90L-16"-3000)	

NOT SHOWN:

FOOTNOTES:

1. 153-639 HYD CONTROL VALVE IS SUPERSEDED BY 150-1815 HYDRAULIC CONTROL VALVE

NOTE:

REFER TO O-RING CHART (800-301) IN BACK OF THE BOOK FOR REPLACEMENT OF O-RINGS.

TRACK CASE DRAIN HYDRAULICS

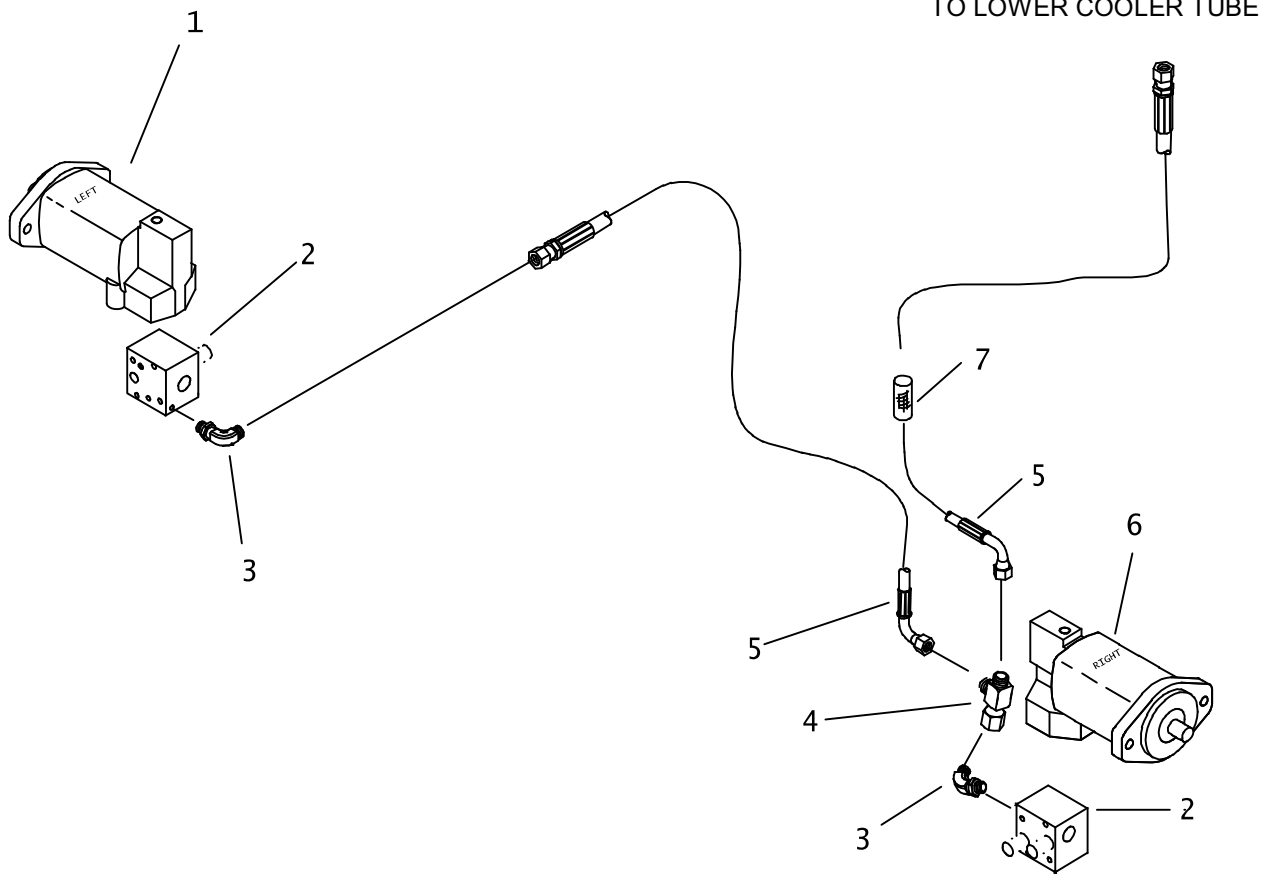

TRACK CASE DRAIN HYDRAULICS

REF NO.	PART NUMBER	QTY	DESCRIPTION	REMARKS
1.	153-593	-	HYDRAULIC MOTOR	
2.	153-767	-	COUNTERBALANCE MANIFOLD	
3.	154-252	2	CONNECTOR (04S-04090)	
4.	154-265	1	UN RUN TEE (040FX-040-040)	
5.	154-728	2	HOSE (040FX90-36"-3000)	
6.	153-592	-	HYDRAULIC MOTOR	USE SEAL KIT 500-752
7.	117-718	1	ABRASION SLEEVE (1.00" X 36")	

NOT SHOWN:

FOOTNOTES:

NOTE:

REFER TO O-RING CHART (800-301) IN BACK OF THE BOOK FOR REPLACEMENT OF O-RINGS.

WRENCH HYDRAULICS

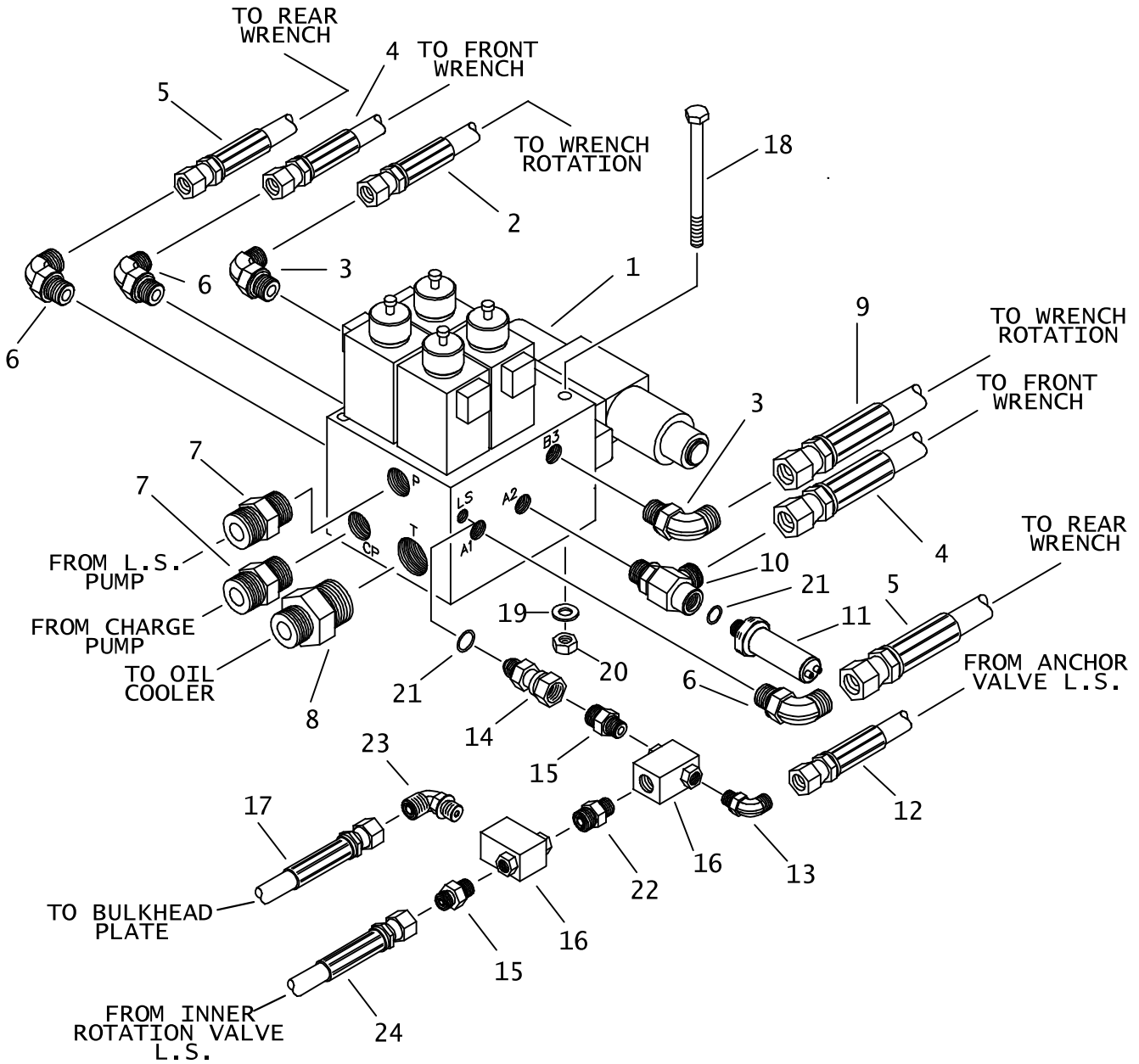

WRENCH HYDRAULICS

REF NO.	PART NUMBER	QTY	DESCRIPTION	REMARKS
1.	153-410	1	HYDRAULIC VALVE	
	499-309	-	SOLENOID	
	499-311	-	SOLENOID CARTRIDGE	
	499-312	-	SOLENOID COIL	
	501-872	-	SHUTTLE VALVE	
	499-313	-	CHECK VALVE	
	191-103	-	SEAL REPAIR KIT	
	191-104	-	SEAL REPAIR KIT	
	500-703	-	SEAL REPAIR KIT	
2.	154-797	-	HOSE (060FX-48"-3000)	
3.	154-227	2	CONNECTOR (060-08S90)	
4.	154-884	-	HOSE (080FX90-60"-3000)	
5.	515-214	-	HOSE (080FX45-80"-3000)	
6.	154-235	3	CONNECTOR (08S-08090)	
7.	154-269	2	CONNECTOR (12S-120)	
8.	154-367	1	CONNECTOR (120-16S)	
9.	154-996	-	HOSE (060FX-58"-3000)	
10.	149-572	1	CONNECTOR (08S-08090-06SF)	
11.	215-1227	1	PRESSURE SWITCH (500PSI)	
12.	515-410	-	HOSE (060FX45-118"-3000)	
13.	154-342	-	CONNECTOR (06S-06090)	
14.	514-409	1	UNION (06J-060FX)	
15.	154-221	-	CONNECTOR (06S-060)	AT ONLY
	510-015	-	ADAPTER (06S-060, ORF)	JT ONLY, INSTALL IN LOCATION 22.
16.	158-600	-	HYD SHUTTLE VALVE	
17.	154-816	-	HOSE (060FX-120"-3000)	
18.	107-420	3	SCREW (M10-1.50 X 140MM)	
19.	106-390	3	WASHER (M10)	
20.	105-894	3	LOCKNUT(M10-1.50, PRV TRQ, 10.9)	
21.	155-705	2	O-RING (906 D90)	
22.	155-153	-	CONNECTOR (06S-06S)	AT ONLY
23.	157-420	-	CONN (06S-06090, ORF .028)	AT ONLY
24.	157-288	-	HOSE (060FX45-234"-3000)	AT ONLY

NOT SHOWN:

FOOTNOTES:

NOTE:

REFER TO O-RING CHART (800-301) IN BACK OF THE BOOK FOR REPLACEMENT OF O-RINGS.

FRONT WRENCH HYDRAULICS

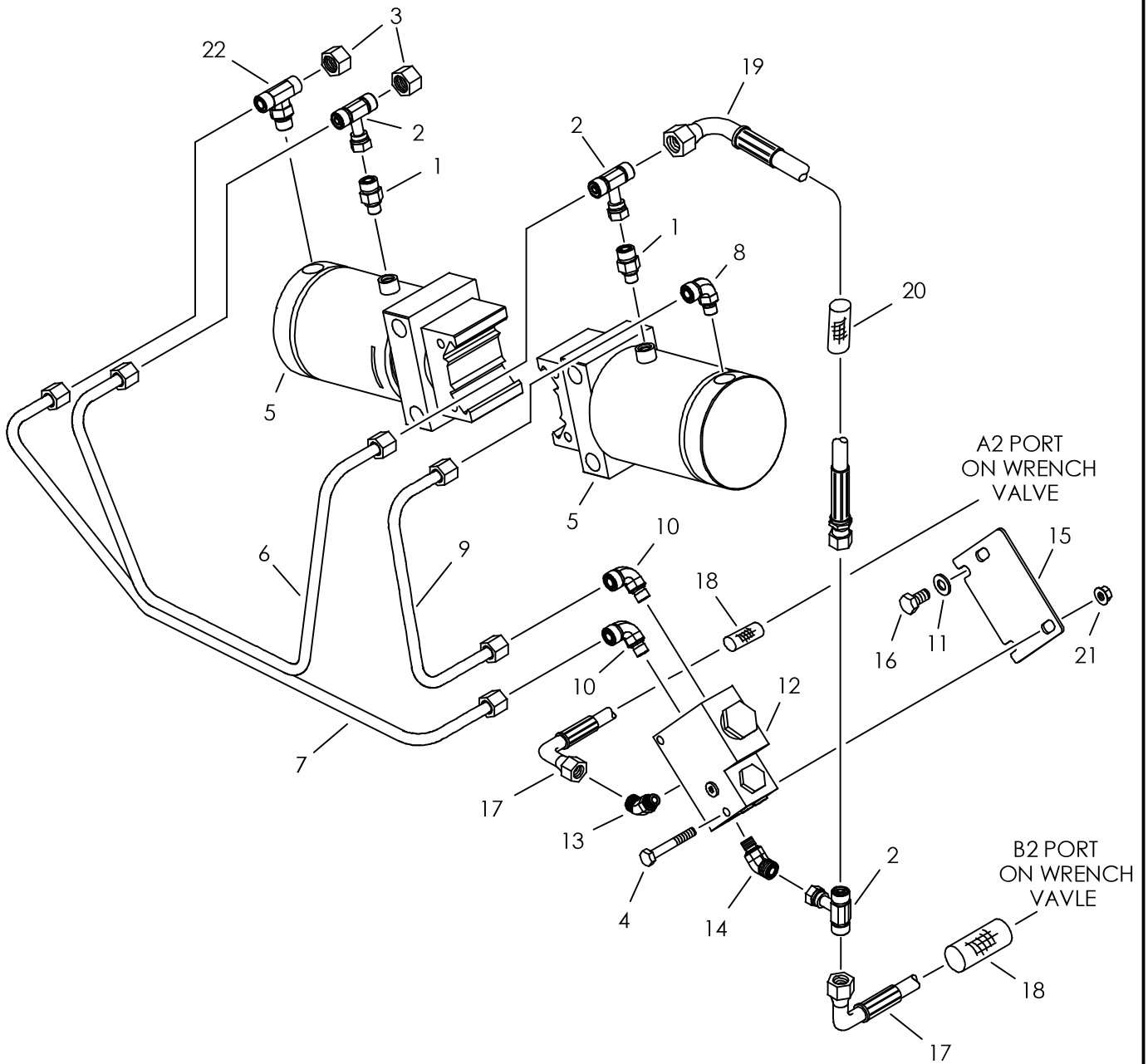

FRONT WRENCH HYDRAULICS

REF NO.	PART NUMBER	QTY	DESCRIPTION	REMARKS
1.	154-246	2	CONNECTOR (06S-080)	
2.	154-257	3	UN BR TEE (080FX-080-080)	
3.	154-327	2	CAP (080F)	
4.	106-142	2	SCREW (M10-1.50 X 65MM)	
5.	151-212	2	CYLINDER ASSEMBLY	4.50" X 2.25" X 2.75"
6.	153-649	1	HYD LINE	
7.	153-650	1	HYDRAULIC LINE (08)	
8.	154-253	1	CONNECTOR (06S-08090)	
9.	153-647	1	HYDRAULIC LINE (-08)	
10.	154-235	2	CONNECTOR (08S-08090)	
11.	106-397	2	WASHER (M12, HARDENED)	
12.	149-791	1	HYDRAULIC CONTROL VALVE	USE SERVICE PARTS: 500-2041 SEAL KIT & 500-2042 SEAL
13.	154-264	1	CONNECTOR (080-10S45)	
14.	154-283	1	CONNECTOR (06S-08045)	
15.	310-911	1	PLATE	
16.	107-521	2	SCREW (M12-1.75 X 20MM)	
17.	154-884	2	HOSE (080FX90-60"-3000)	
18.	117-392	2	ABRASION SLEEVE (1.25" X 60")	
19.	154-750	1	HOSE (080FX90-28"-3000)	
20.	117-396	1	ABRASION SLEEVE (1.25" X 28")	
21.	107-661	2	FLG LKNUT (M10-1.50, PRV TRQ)	
22.	153-728	1	TEE (06S-080-080)	

NOT SHOWN:

FOOTNOTES:

NOTE:

REFER TO O-RING CHART (800-301) IN BACK OF THE BOOK FOR REPLACEMENT OF O-RINGS.

REAR WRENCH HYDRAULICS

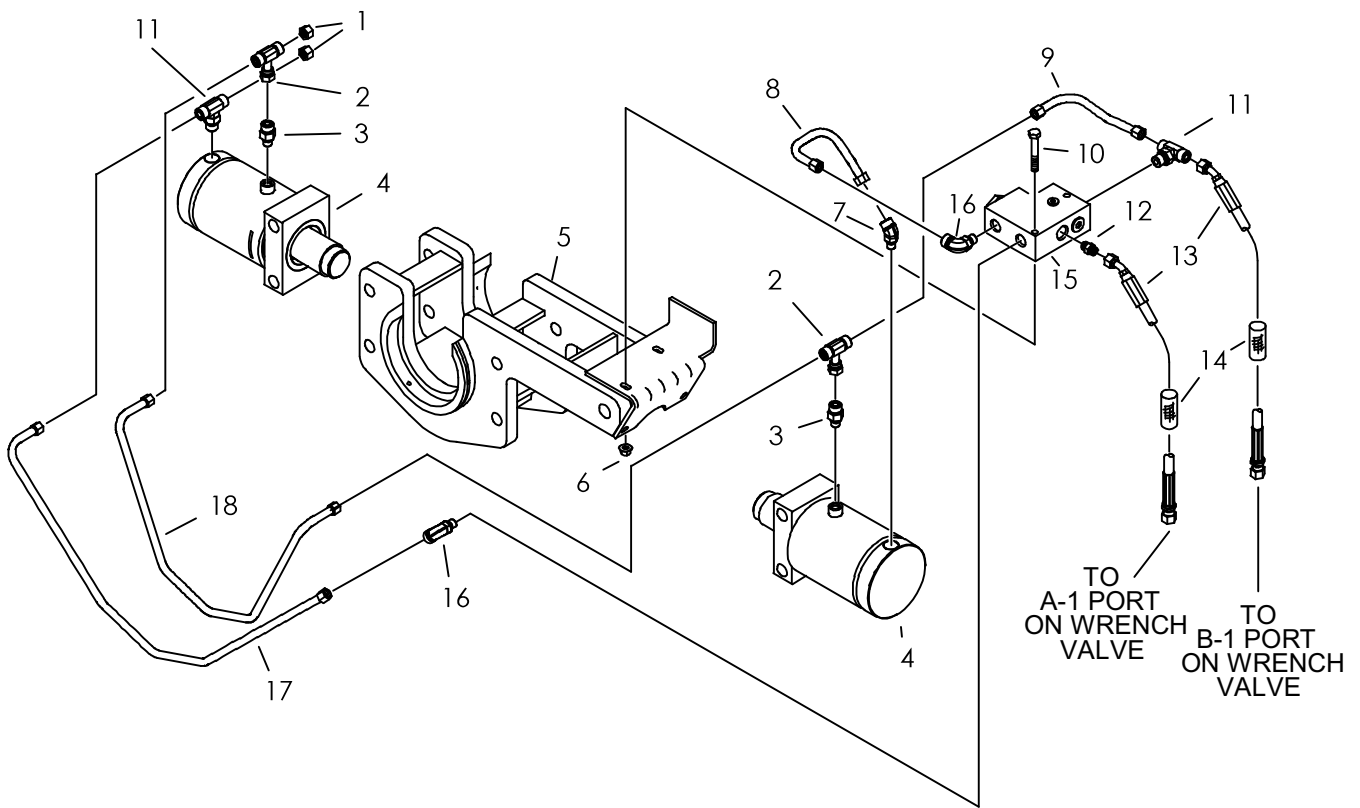

REAR WRENCH HYDRAULICS

REF NO.	PART NUMBER	QTY	DESCRIPTION	REMARKS
1.	154-327	2	CAP (080F)	
2.	154-257	2	UN BR TEE (080FX-080-080)	
3.	154-246	2	CONNECTOR (06S-080)	
4.	151-212	-	CYLINDER ASSEMBLY	
5.	313-717	-	ROTATION CLAMP	
6.	107-661	2	FLG LKNUT (M10-1.50, PRV TRQ)	
7.	154-283	1	CONNECTOR (06S-08045)	
8.	153-726	1	HYDRAULIC LINE (-08)	
9.	153-648	1	HYDRAULIC LINE (-08)	
10.	106-332	2	SCREW (M10-1.50 X 70MM)	
11.	153-728	2	TEE (06S-080-080)	
12.	154-279	1	CONNECTOR (080-10S)	
13.	515-214	2	HOSE (080FX45-80"-3000)	
14.	117-556	2	ABRASION SLEEVE (1.25" X 80")	
15.	149-791	1	HYDRAULIC CONTROL VALVE	USE SERVICE PARTS: 500-2041 SEAL KIT & 500-2042 SEAL
16.	154-235	2	CONNECTOR (08S-08090)	
17.	153-651	1	HYDRAULIC LINE (-08)	
18.	153-652	1	HYDRAULIC LINE (-08)	

NOT SHOWN:

FOOTNOTES:

NOTE:

REFER TO O-RING CHART (800-301) IN BACK OF THE BOOK FOR REPLACEMENT OF O-RINGS.

WRENCH ROTATE HYDRAULICS

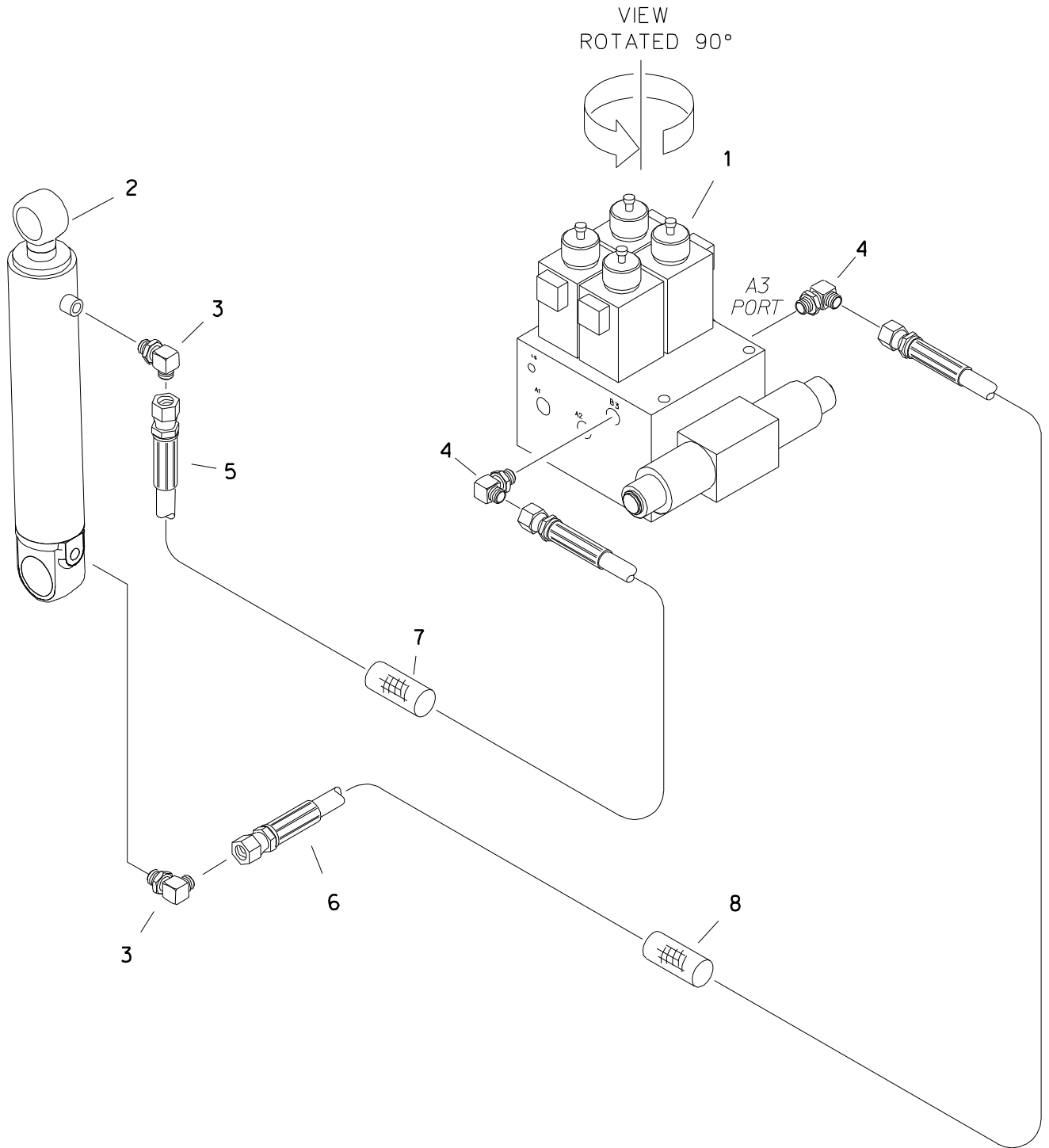

WRENCH ROTATE HYDRAULICS

REF NO.	PART NUMBER	QTY	DESCRIPTION	REMARKS
1.	153-410	-	HYDRAULIC VALVE	
2.	151-031	-	CYL (2.0" X 1.0" X 8.0")	
3.	514-049	2	CONNECTOR (04S-06090)	
4.	154-227	-	CONNECTOR (060-08S90)	
5.	154-996	1	HOSE (060FX-58"-3000)	
6.	154-797	1	HOSE (060FX-48"-3000)	
7.	117-326	1	ABRASION SLEEVE (1.00" X 58")	
8.	117-416	1	ABRASION SLEEVE (1.00" X 50")	

FOOTNOTES

NOTES

REFER TO O-RING CHART (800-301) IN BACK OF THE BOOK FOR REPLACEMENT OF O-RINGS.

ANCHOR SUPPLY HYDRAULICS

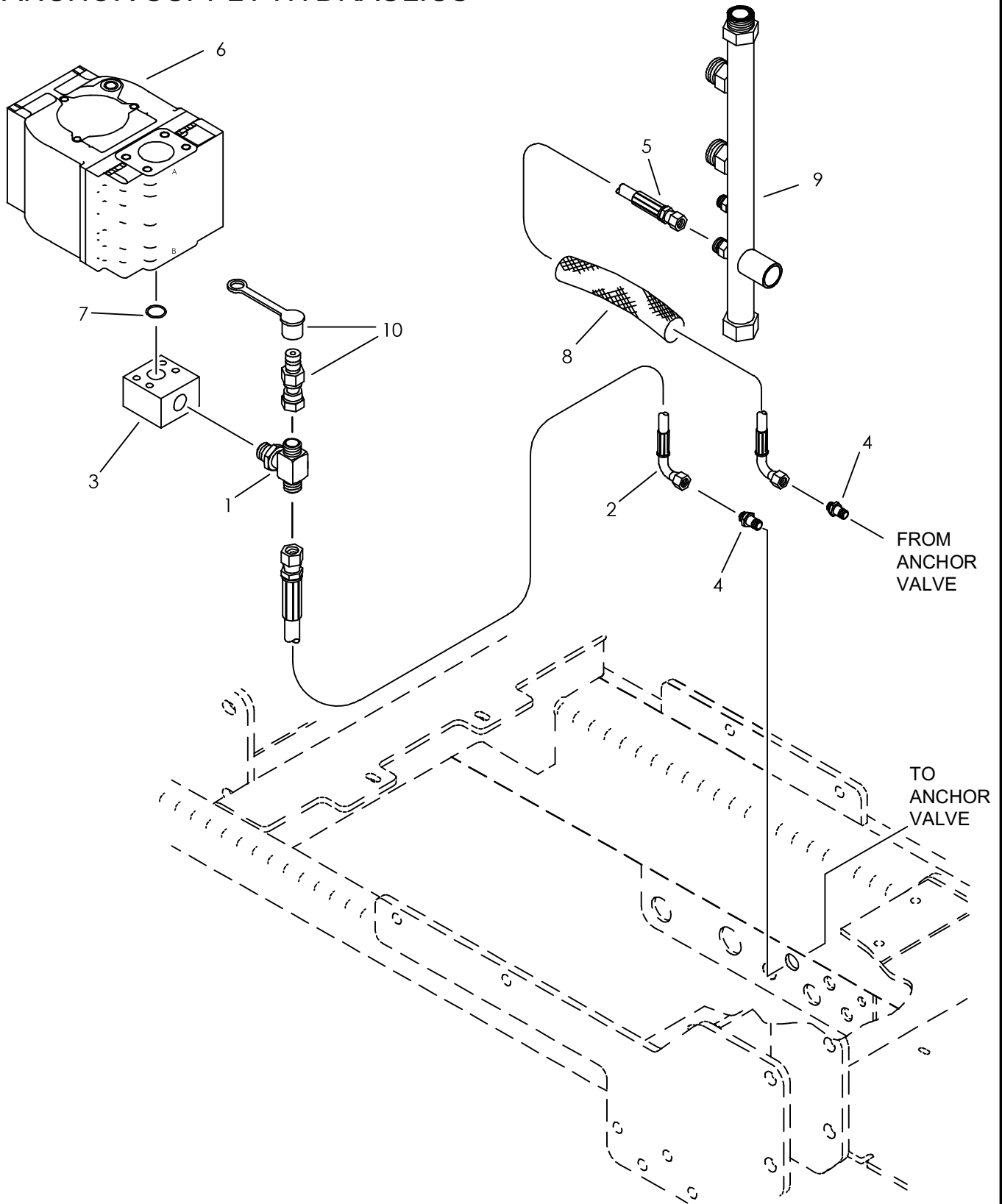

ANCHOR SUPPLY HYDRAULICS

REF NO.	PART NUMBER	QTY	DESCRIPTION	REMARKS
1.	154-318	1	BRANCH TEE (10S-100-100)	
2.	515-454	1	HOSE (100FX90L-20"-3000)	
3.	153-393	1	MANIFOLD BLOCK	
4.	154-309	2	BK CONNECTOR (100-100BK)	
5.	515-690	1	HOSE (100FX90L-58"-3000)	
6.	150-2180	-	HYDRAULIC PUMP LS	
	190-1371	-	PUMP SEAL KIT	
7.	157-128	-	O-RING (225 D90)	
8.	115-903	1	ABRASION SLEEVE (1.59" X 50")	
9.	153-389	-	COOLER BY-PASS	
10.	159-159	1	QDC ADAPTER (02-100FX)	
	159-148	1	DUST CAP (1/8")	

NOT SHOWN:

FOOTNOTES:

NOTE:

REFER TO O-RING CHART (800-301) IN BACK OF THE BOOK FOR REPLACEMENT OF O-RINGS.

ANCHOR VALE PRESSURE & RETURN HYDRAULICS

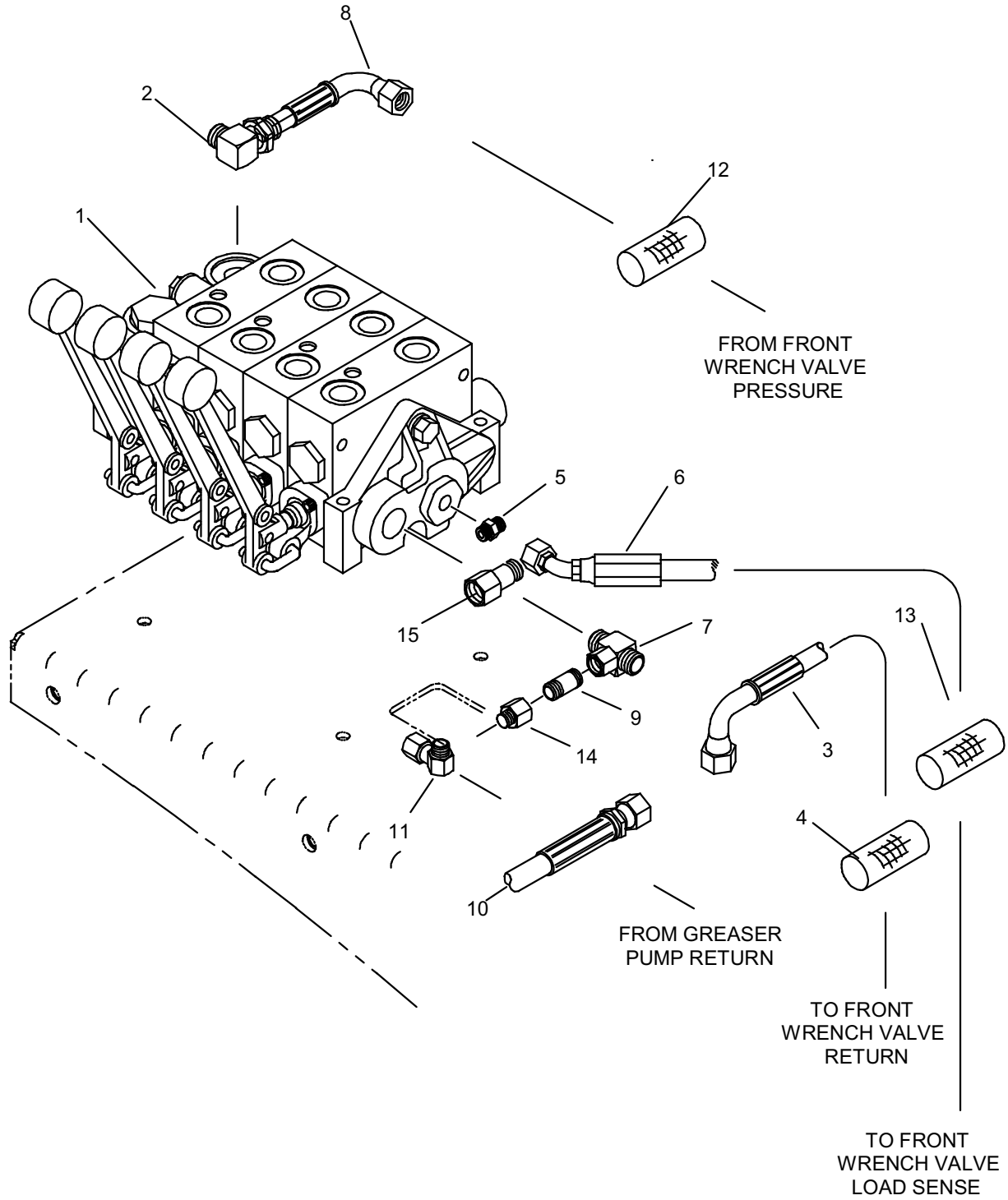

ANCHOR VALE PRESSURE & RETURN HYDRAULICS

REF NO.	PART NUMBER	QTY	DESCRIPTION	REMARKS
1.	158-064	1	HYD CONTROL VALVE (4-SPOOL)	
2.	154-300	1	CONNECTOR (100-12S90)	
3.	515-670	1	HOSE (100FX90-85"-3000)	
4.	115-817	1	ABRASION SLEEVE (1.59" X 84")	
5.	154-411	1	CONNECTOR (04S-060)	
6.	515-410	1	HOSE (060FX45-118"-3000)	
7.	154-458	1	UNION RUN TEE (06SFS-10S-100)	
8.	515-618	1	HOSE (100FX90-95"-3000)	
9.	159-381	1	CHECK VALVE (06S-060)	
10.	149-827	1	HOSE (040FX90S-24"-3000)	
11.	154-255	1	UNION (040-040FX90)	
12.	116-787	1	ABRASION SLEEVE (1.59" X 95")	
13.	117-212	1	ABRASION SLEEVE (1.25" X 118")	
14.	154-373	1	REDUCER (040-060F)	
15.	510-017	1	REDUCER (12S-10SF)	

NOT SHOWN:

FOOTNOTES:

NOTE:

REFER TO O-RING CHART (800-301) IN BACK OF THE BOOK FOR REPLACEMENT OF O-RINGS.

RIGHT ANCHOR MOTOR HYDRAULICS

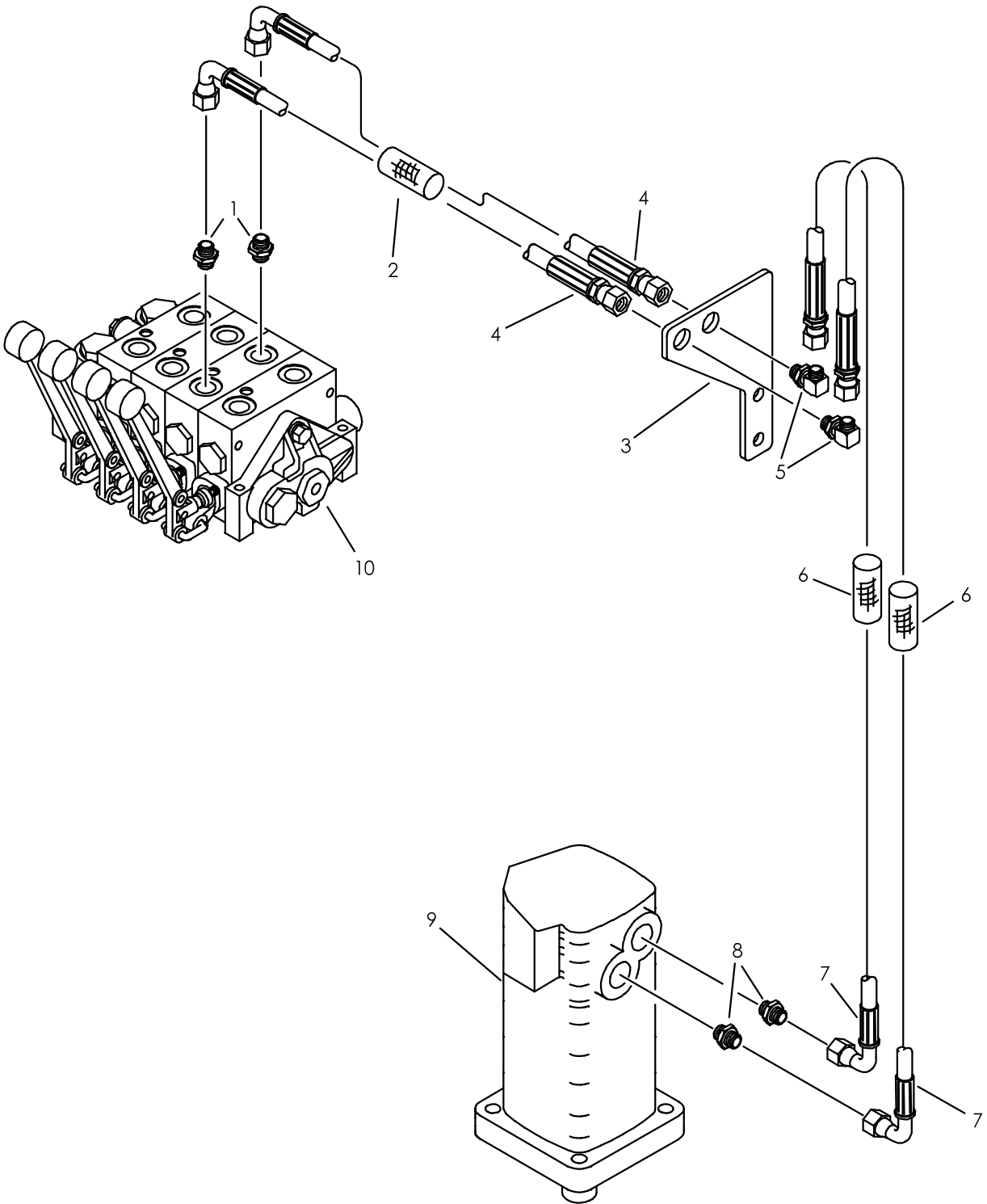

RIGHT ANCHOR MOTOR HYDRAULICS

REF NO.	PART NUMBER	QTY	DESCRIPTION	REMARKS
1.	154-233	2	CONNECTOR (08S-080)	
2.	117-455	1	ABRASION SLEEVE (2.07" X 38")	
3.	309-204	1	BULKHEAD PLATE	
4.	515-025	2	HOSE (080FX90-40"-3000)	
5.	154-396	2	BK CONNECTOR (080-08090BK)	
6.	117-324	2	ABRASION SLEEVE (1.25" X 48")	
7.	154-716	2	HOSE (080FX90-48"-3000)	
8.	154-307	2	CONNECTOR (16S-080)	
9.	149-895	-	HYD MOTOR	
	500-390		SEAL REPAIR KIT - REAR	
	500-391		SEAL REPAIR KIT - SHAFT	
	502-177		SHAFT AND BEARING ASS'Y	
	500-2123		FRONT RETAINER (ANCHOR MOTOR)	
10.	158-064	-	HYD CONTROL VALVE (4-SPOOL)	

NOT SHOWN:

FOOTNOTES:

NOTE:

REFER TO O-RING CHART (800-301) IN BACK OF THE BOOK FOR REPLACEMENT OF O-RINGS

LEFT ANCHOR MOTOR HYDRAULICS

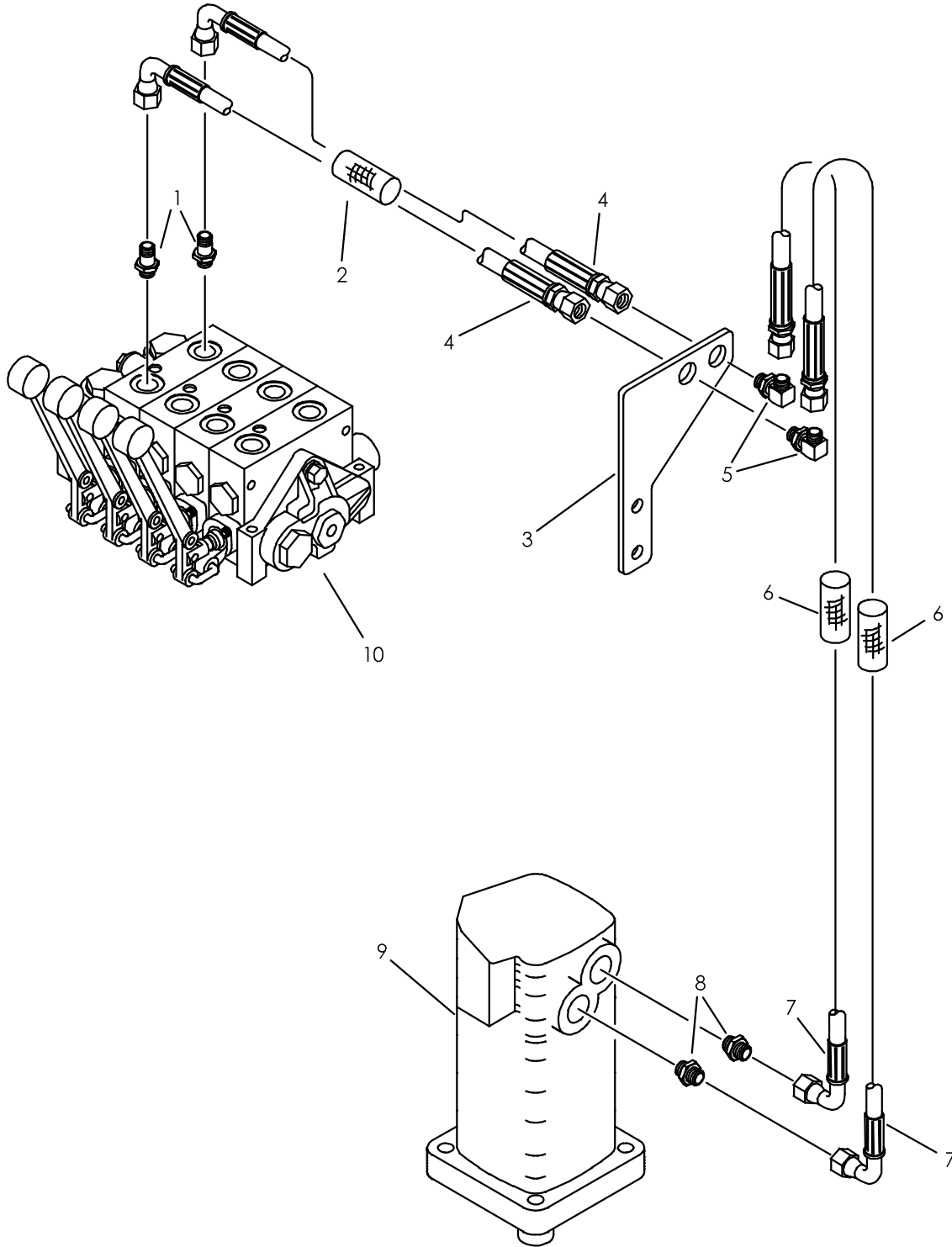

LEFT ANCHOR MOTOR HYDRAULICS

REF NO.	PART NUMBER	QTY	DESCRIPTION	REMARKS
1.	154-438	2	CONNECTOR (08S-080, LG)	
2.	117-293	1	ABRASION SLEEVE (2.07" X 46")	
3.	309-204	1	BULKHEAD PLATE	
4.	154-716	2	HOSE (080FX90-48"-3000)	
5.	154-396	2	BK CONNECTOR (080-08090BK)	
6.	117-324	2	ABRASION SLEEVE (1.25" X 48")	
7.	154-716	2	HOSE (080FX90-48"-3000)	
8.	154-307	2	CONNECTOR (16S-080)	
9.	149-895	-	HYD MOTOR	
	500-390		SEAL REPAIR KIT - REAR	
	500-391		SEAL REPAIR KIT - SHAFT	
	502-177		SHAFT AND BEARING	
10.	158-064	-	HYD CONTROL VALVE (4-SPOOL)	

NOT SHOWN:

FOOTNOTES:

NOTE:

REFER TO O-RING CHART (800-301) IN BACK OF THE BOOK FOR REPLACEMENT OF O-RINGS.

RIGHT ANCHOR THRUST CYLINDER

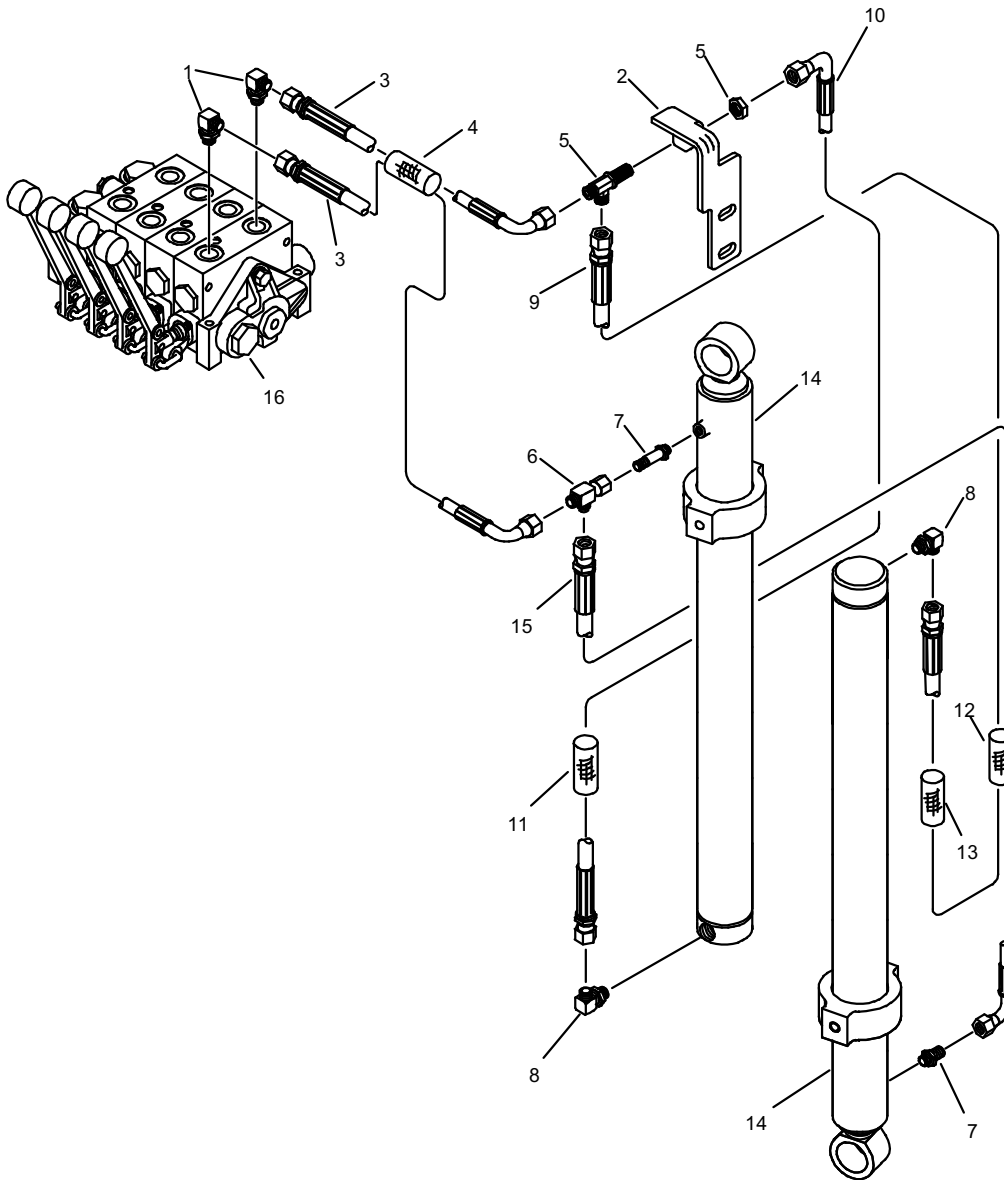

RIGHT ANCHOR THRUST CYLINDER

REF NO.	PART NUMBER	QTY	DESCRIPTION	REMARKS
1.	154-276	2	CONNECTOR (040-08S90)	
2.	309-205	1	BULKHEAD PLATE	
3.	154-728	2	HOSE (040FX90-36"-3000)	
4.	117-655	1	ABRASION SLEEVE (1.59" X 38")	
5.	154-424	1	BK RUN TEE (040-040-040BK)	
6.	154-265	1	UNION RUN TEE (040FX-040-040)	
7.	154-403	2	CONNECTOR (04S-040, XL)	
8.	154-252	2	CONNECTOR (04S-04090)	
9.	515-054	1	HOSE (040FX-74"-3000)	
10.	515-683	1	HOSE (040FX90-28"-3000)	
11.	117-684	1	ABRASION SLEEVE (1.00" X 26")	
12.	117-657	1	ABRASION SLEEVE (1.59" X 54")	
13.	117-676	1	ABRASION SLEEVE (1.00" X 30")	
14.	150-747	2	CYLINDER ASSEMBLY	
15.	515-682	1	HOSE (040FX90M-48"-3000)	
16.	158-064	-	HYD CONTROL VALVE (4-SPOOL)	

NOT SHOWN:

FOOTNOTES:

NOTE:

REFER TO O-RING CHART (800-301) IN BACK OF THE BOOK FOR REPLACEMENT OF O-RINGS.

LEFT ANCHOR THRUST CYLINDER

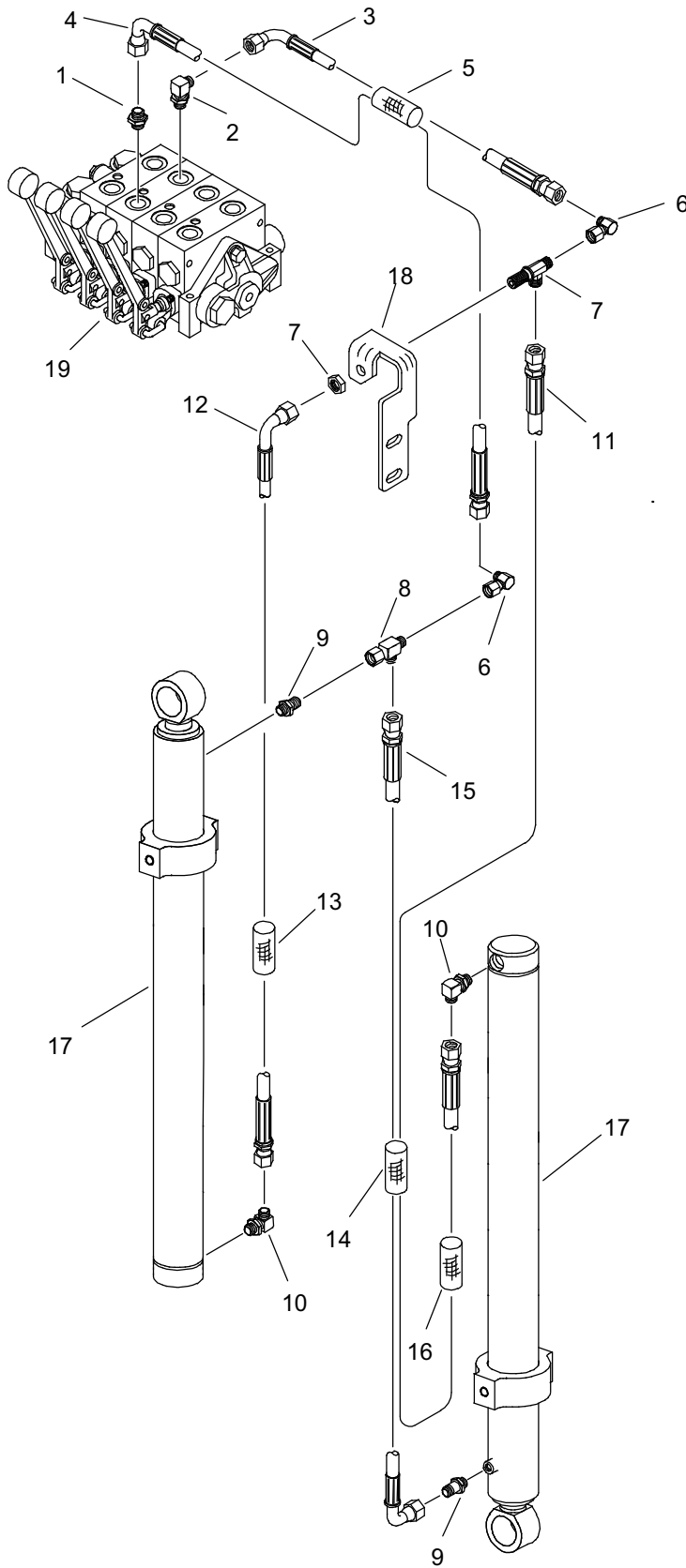

LEFT ANCHOR THRUST CYLINDER

REF NO.	PART NUMBER	QTY	DESCRIPTION	REMARKS
1.	154-261	1	CONNECTOR (040-08S)	
2.	154-276	1	CONNECTOR (040-08S90)	
3.	515-593	1	HOSE (040FX90-38"-3000)	
4.	515-012	1	HOSE (040FX90-42"-3000)	
5.	115-737	1	ABRASION SLEEVE (1.59" X 40")	
6.	154-255	2	UNION (040-040FX90)	
7.	154-424	1	BK RUN TEE (040-040-040BK)	
8.	154-265	1	UNION RUN TEE (040FX-040-040)	
9.	154-403	2	CONNECTOR (04S-040, XL)	
10.	154-252	2	CONNECTOR (04S-04090)	
11.	515-054	1	HOSE (040FX-74"-3000)	
12.	515-683	1	HOSE (040FX90-28"-3000)	
13.	117-684	1	ABRASION SLEEVE (1.00" X 26")	
14.	117-657	1	ABRASION SLEEVE (1.59" X 54")	
15.	515-682	1	HOSE (040FX90M-48"-3000)	
16.	117-676	1	ABRASION SLEEVE (1.00" X 30")	
17.	150-747	2	CYLINDER ASSEMBLY	
18.	309-206	1	BULKHEAD PLATE	
19.	158-064	-	HYD CONTROL VALVE (4-SPOOL)	

NOT SHOWN:

FOOTNOTES:

NOTE:

REFER TO O-RING CHART (800-301) IN BACK OF THE BOOK FOR REPLACEMENT OF O-RINGS.

AUXILIARY VALVE

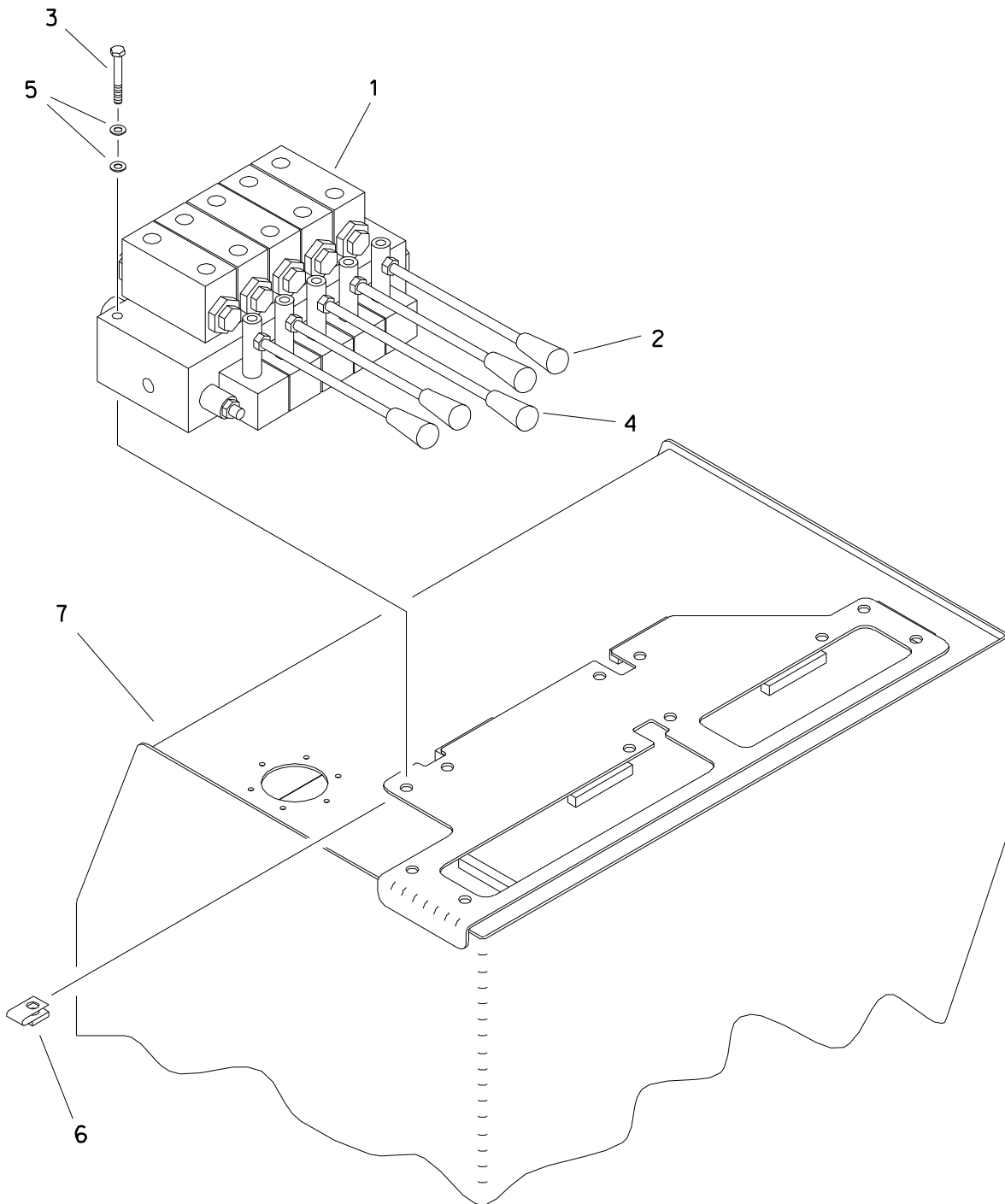

AUXILIARY VALVE

REF NO.	PART NUMBER	QTY	DESCRIPTION	REMARKS
1.	149-882	-	HYD CONTROL VALVE (5-SPOOL)	
2.	365-426	4	LEVER (M8-1.25 X 200MM)	
3.	106-595	3	SCREW (M6-1.00 X 60MM)	
4.	500-502	1	CONTROL VALVE HANDLE	
5.	106-076	6	WASHER (1/4")	
6.	106-574	3	CLIP NUT (M6-1.00)	
7.	350-614	-	HYD RESERVOIR	

FOOTNOTES

AUXILIARY SUPPLY & RETURN HYDRAULICS

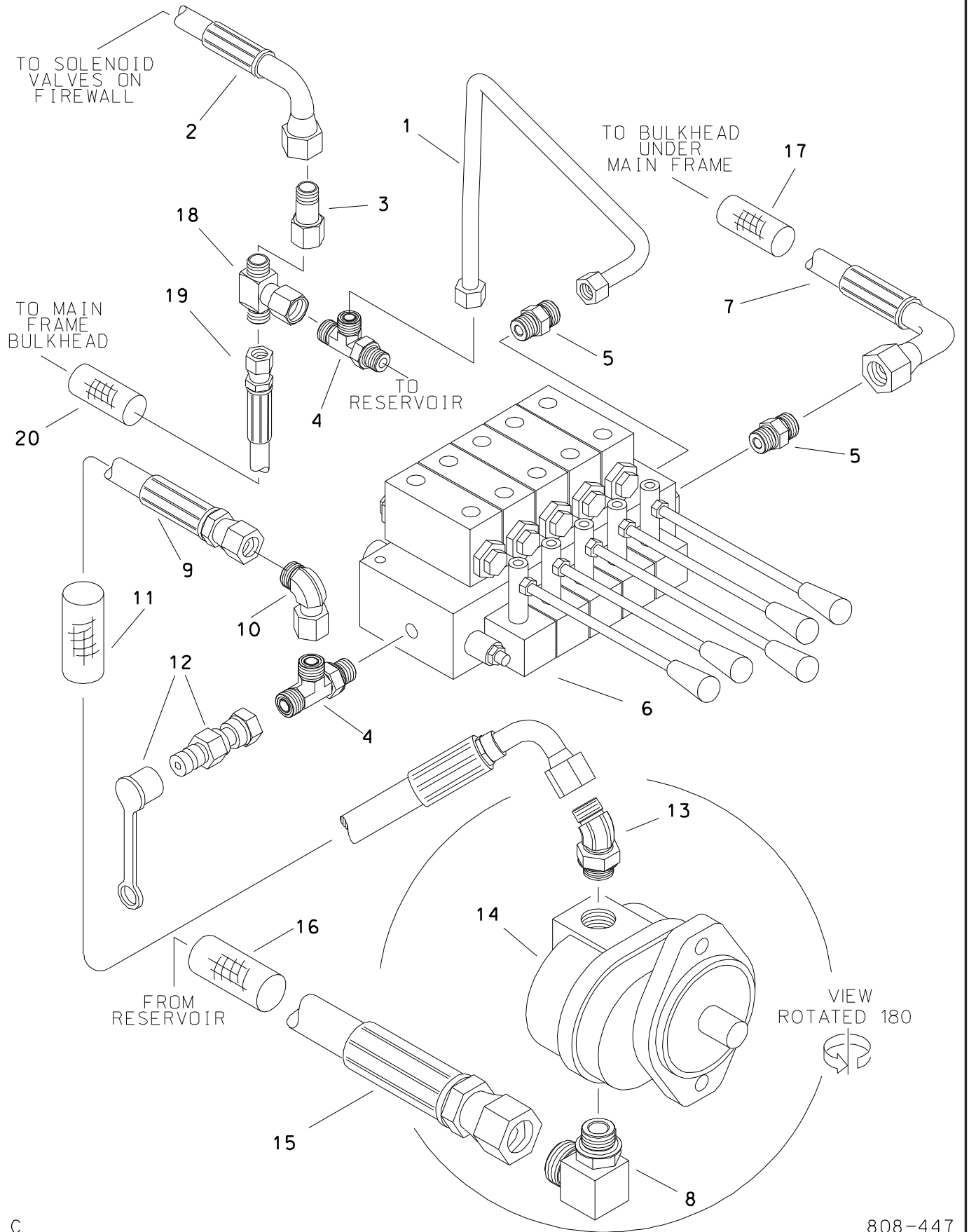

AUXILIARY SUPPLY & RETURN HYDRAULICS

REF NO.	PART NUMBER	QTY	DESCRIPTION	REMARKS
1.	153-106	1	HYD LINE	
2.	515-221	-	HOSE (060FX90S-28"-3000)	
3.	154-262	1	REDUCER (060-080F)	
4.	154-299	2	RUN TEE (08S-080-080)	
5.	154-233	2	CONNECTOR (08S-080)	
6.	149-882	-	HYD CONTROL VALVE (5-SPPOOL)	
7.	515-140	1	HOSE (080FX90-56"-3000)	
8.	154-286	1	CONNECTOR (120-16S90)	
9.	154-955	1	HOSE (080FX90-102"-3000)	
10.	154-256	1	UNION (080-080FX90)	
11.	115-902	1	ABRASION SLEEVE (1.59" X 100")	
12.	159-158	1	QDC ADAPTER (02-080FX)	
	159-148	-	DUST CAP (1/8")	
13.	154-264	1	CONNECTOR (080-10S45)	
14.	149-838	1	HYDRAULIC PUMP	
15.	154-862	1	HOSE (120FX-80"-2250)	
16.	115-817	1	ABRASION SLEEVE (1.59" X 84")	
17.	117-655	1	ABRASION SLEEVE (1.59" X 38")	
18.	154-257	1	UN BR TEE (080FX-080-080)	
19.	154-739	1	HOSE (080FX-32"-3000)	
20.	117-396	1	ABRASION SLEEVE (1.25" X 28")	

NOTES:

REFER TO O-RING CHART (800-301) IN BACK OF THE BOOK FOR REPLACEMENT OF O-RINGS.

STABILIZER HYDRAULICS

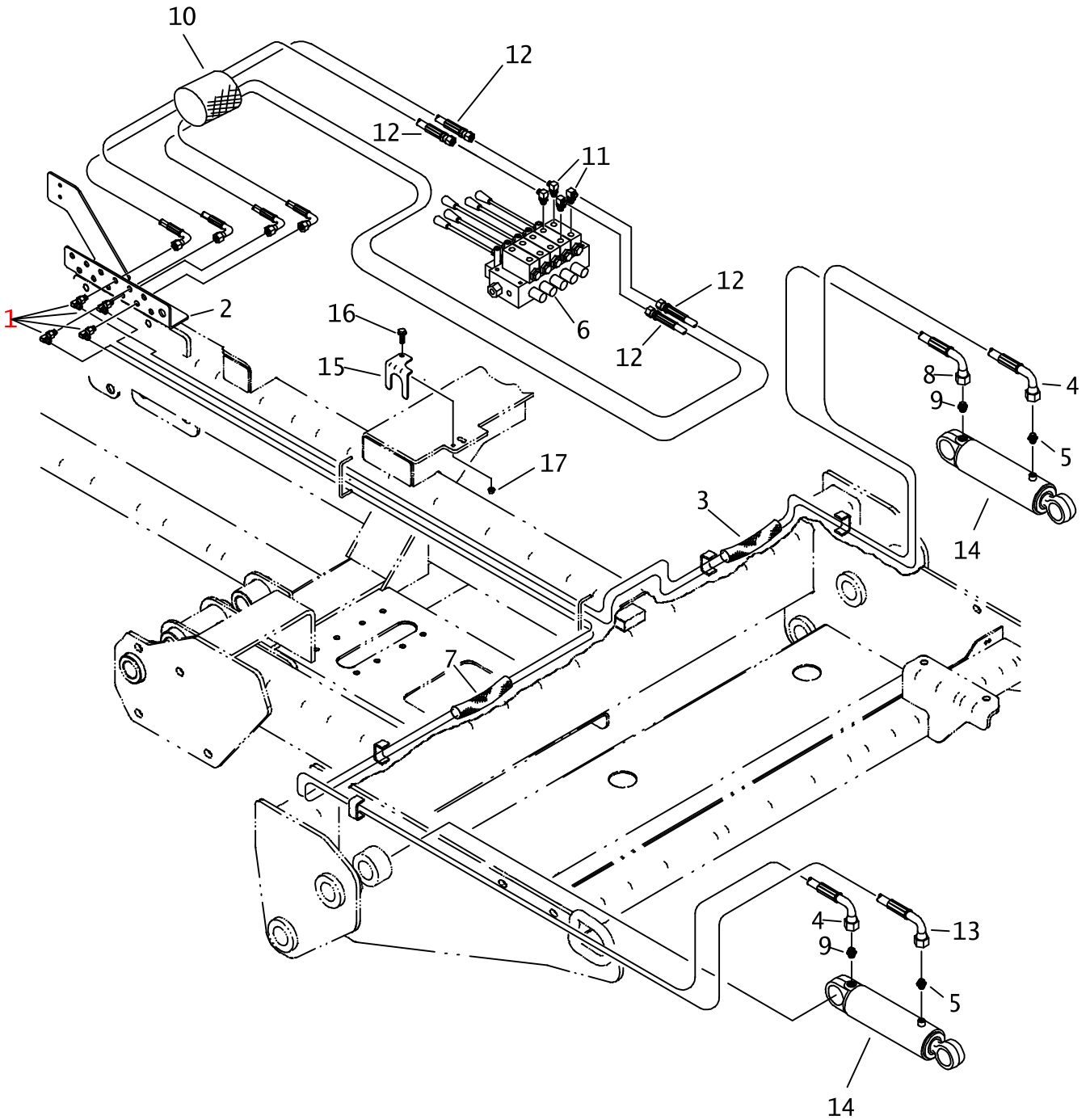

STABILIZER HYDRAULICS

REF NO.	PART NUMBER	QTY	DESCRIPTION	REMARKS
1.	154-355	4	BK CONNECTOR (040-04090BK)	
2.	354-466	-	BULKHEAD PLATE	
3.	116-633	1	ABRASION SLEEVE (1.59" X 115")	
4.	515-277	2	HOSE (040FX90S-128"-3000)	
5.	154-261	2	CONNECTOR (040-08S)	
6.	149-882	1	HYD CONTROL VALVE (5-SPOOL)	
7.	116-632	1	ABRASION SLEEVE (1.59" X 130")	
8.	515-239	1	HOSE (040FX90S-116"-3000)	
9.	154-374	1	CONNECTOR (040-08S, ORF)	
10.	117-789	-	HOSE BAG (4" X 36")	
11.	154-226	4	CONNECTOR (040-06S90)	
12.	515-439	4	HOSE (040FX90S-50"-3000)	
13.	515-146	1	HOSE (040FX90S-140"-3000)	
14.	151-187	2	CYLINDER ASSEMBLY	4" X 2" X 10"
15.	309-549	1	BRACKET	
16.	106-381	1	FLG LK SCREW (M8-1.25 X 25MM)	
17.	106-386	1	FLG LOCKNUT (M8-1.25)	

NOT SHOWN:

FOOTNOTES:

NOTE:

REFER TO O-RING CAHRT (800-301) IN BACK OF THE BOOK FOR REPLACEMENT OF O-RINGS.

SHUTTLE STOP HYDRAULICS

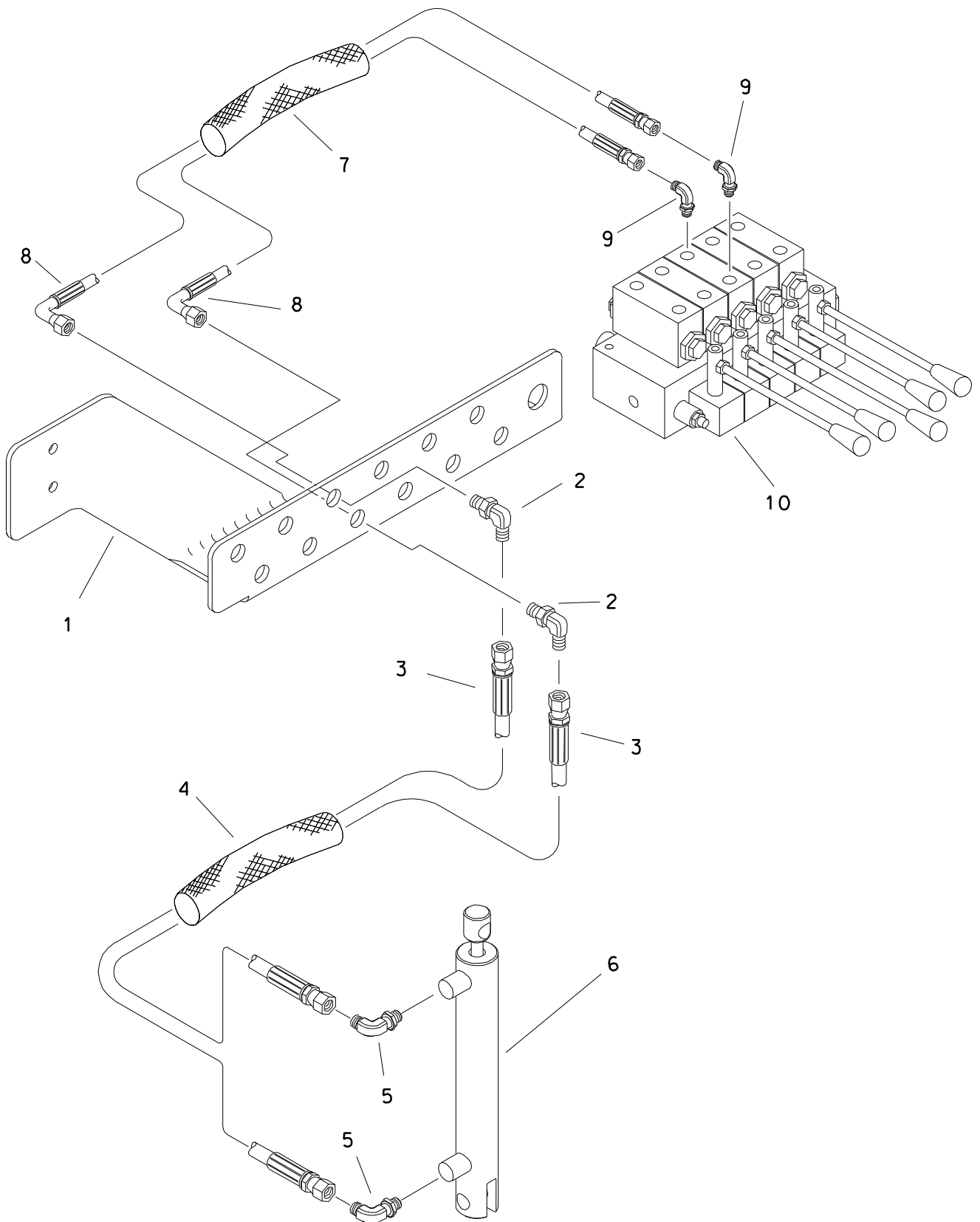

SHUTTLE STOP HYDRAULICS

REF NO.	PART NUMBER	QTY	DESCRIPTION	REMARKS
1.	354-466	1	BULKHEAD PLATE	
2.	154-355	2	BK CONNECTOR (040-04090BK)	
3.	515-161	2	HOSE (040FX-160"-3000)	
4.	117-741	1	ABRASION SLEEVE (1.59" X 145")	
5.	154-401	2	CONNECTOR (04S-04090, ORF)	
6.	150-727	1	CYL (1.0" X .500" X 4.0")	
7.	117-789	-	HOSE BAG (4.000" X 36")	
8.	515-447	2	HOSE (040FX90S-48"-3000)	
9.	154-226	2	CONNECTOR (040-06S90)	
10.	149-882	-	HYD CONTROL VALVE (5-SPOOL)	

FOOTNOTES

NOTE
REFER TO O-RING CHART (800-301) IN BACK OF THE BOOK FOR THE REPLACEMENT OF O-RINGS.

FRAME TILT HYDRAULICS

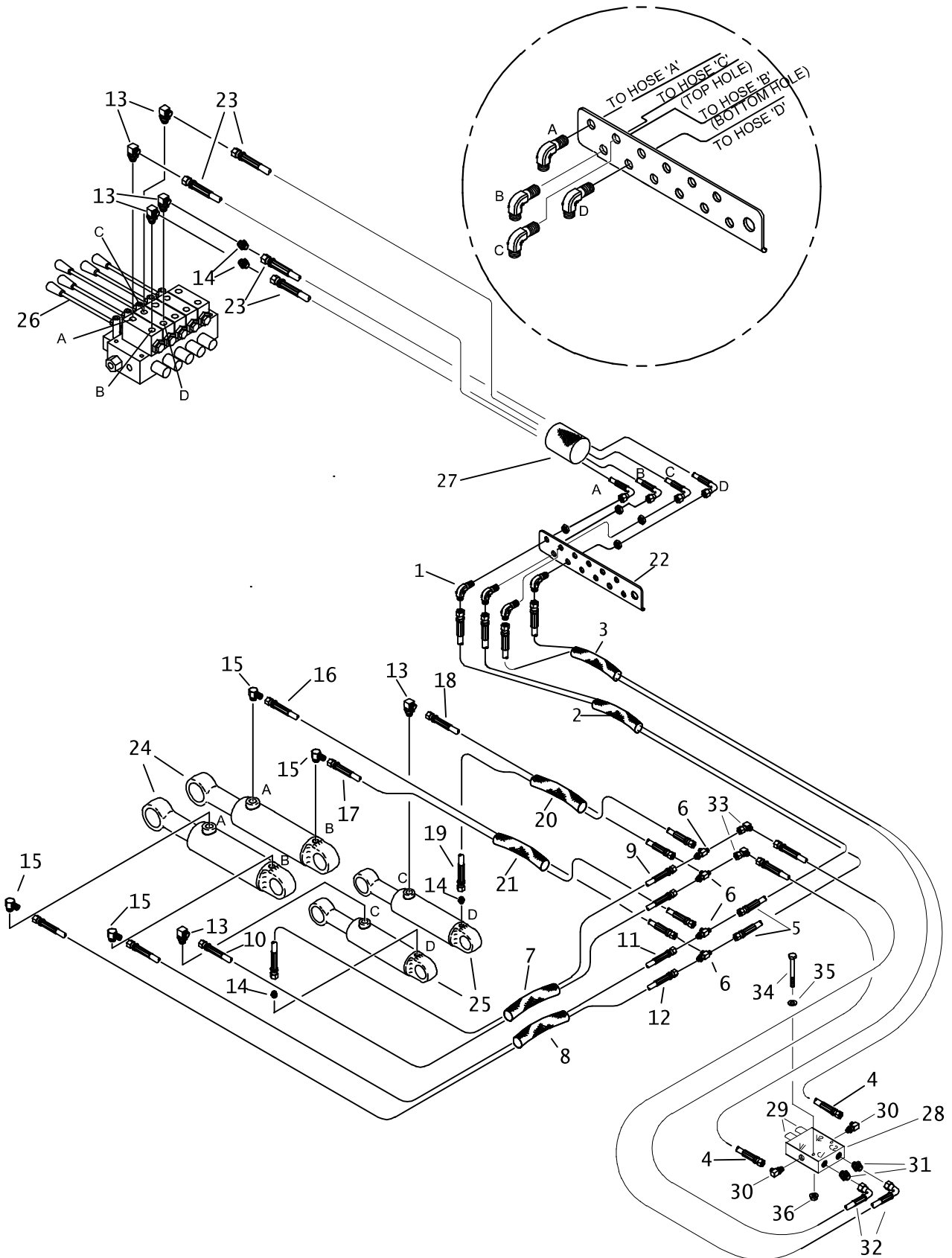

FRAME TILT HYDRAULICS

REF NO.	PART NUMBER	QTY	DESCRIPTION	REMARKS
1.	154-355	4	BK CONNECTOR (040-04090BK)	
2.	117-603	1	ABRASION SLEEVE (1.59" X 62")	
3.	117-656	1	ABRASION SLEEVE (1.59" X 45")	
4.	515-424	2	HOSE (040FX-56"-3000)	
5.	154-681	2	HOSE (040FX-62"-3000)	
6.	154-424	4	BK RUN TEE (040-040-040BK)	
7.	115-777	1	ABRASION SLEEVE (1.59" X 15")	
8.	117-679	1	ABRASION SLEEVE (1.59" X 32")	
9.	154-672	1	HOSE (040FX-15"-3000)	
10.	515-735	1	HOSE (040FX-22"-3000)	
11.	154-668	1	HOSE (040FX-32"-3000)	
12.	154-653	1	HOSE (040FX-40"-3000)	
13.	154-226	6	CONNECTOR (040-06S90)	
14.	154-220	2	CONNECTOR (040-06S)	
15.	154-276	4	CONNECTOR (040-08S90)	
16.	154-911	1	HOSE (040FX-36"-3000AR)	
17.	515-509	1	HOSE (040FX-28"-3000)	
18.	155-484	1	HOSE (040FX-16"-3000)	
19.	154-719	1	HOSE (040FX-10"-3000)	
20.	115-776	1	ABRASION SLEEVE (1.59" X 7")	
21.	117-708	1	ABRASION SLEEVE (1.59" X 28")	
22.	354-466	-	BULKHEAD PLATE	
23.	515-447	4	HOSE (040FX90S-48"-3000)	
24.	151-066	2	CYL (4.0 X 2.0 X 5.0)	
25.	151-070	2	CYL (3.0" X 1.75" X 8.000")	
26.	149-882	-	HYD CONTROL VALVE (5-SPOOL)	
27.	117-789	1	HOSE BAG (4.000" X 36")	ALL HOSES FROM VALVE (149-882) GO INTO HOSE BAG.
28.	502-184	1	VALVE BLOCK	SEE FOOTNOTE 1
29.	500-478	2	COUNTERBALANCE CARTRIDGE KIT	SEE FOOTNOTE 1 & 2
30.	154-226	2	CONNECTOR (040-06S90)	SEE FOOTNOTE 1
31.	154-220	2	CONNECTOR (040-06S)	SEE FOOTNOTE 1
32.	154-726	2	HOSE (040FX90-15"-3000)	SEE FOOTNOTE 1
33.	154-255	2	UNION (040-040FX90)	SEE FOOTNOTE 1
34.	106-570	1	SCREW (M8-1.25 X 60MM)	SEE FOOTNOTE 1
35.	105-117	1	WASHER (5/16")	SEE FOOTNOTE 1
36.	106-386	1	FLG LOCKNUT (M8-1.25)	SEE FOOTNOTE 1

NOT SHOWN:

FOOTNOTES:

1. USE ON 4020 WITH RACK AND PINION
2. TURN ADJUSTMENT SCREW COMPLETELY OUT

NOTE:

REFER TO O-RING CHART (800-301) IN BACK OF THE BOOK FOR REPLACEMENT OF O-RINGS.

PIPE LOADER SUPPLY & RETURN

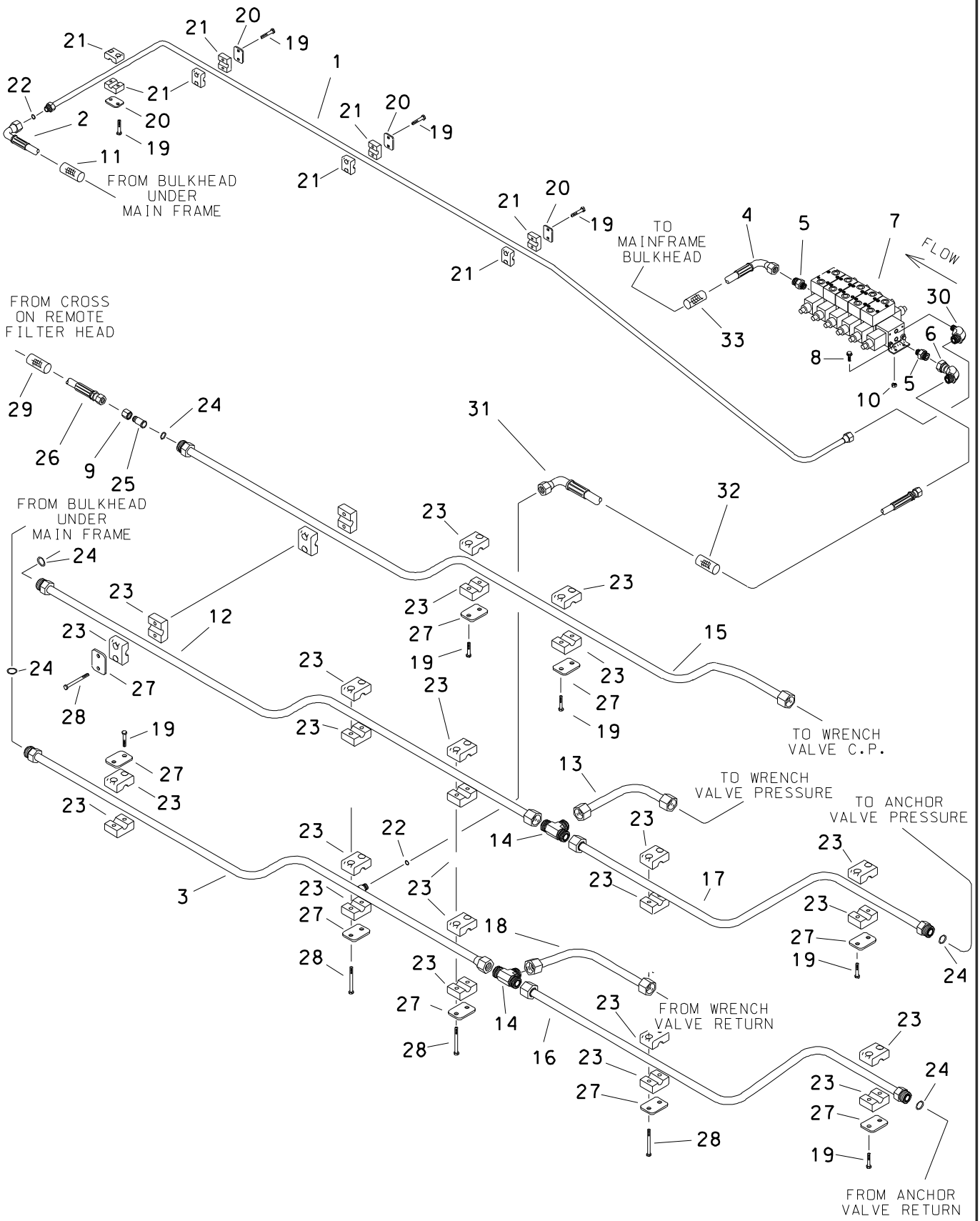

PIPE LOADER SUPPLY & RETURN

REF NO.	PART NUMBER	QTY	DESCRIPTION	REMARKS
1.	149-449	1	HYD LINE	
2.	515-141	1	HOSE (080FX90-82"-3000)	
3.	149-447	1	HYD LINE	
4.	515-741	1	HOSE (080FX90S-112"-3000)	
5.	154-246	2	CONNECTOR (06S-080)	
6.	154-256	1	UNION (080-080FX90)	
7.	157-764	1	HYDRAULIC VALVE	
8.	106-379	4	FLG LK SCREW (M6-1.00 X 20MM)	
9.	154-310	1	REDUCER NUT (100F)	
10.	106-385	4	FLG LOCKNUT (M6-1.00)	
11.	117-390	1	ABRASION SLEEVE (1.25" X 85")	
12.	149-446	1	HYD LINE	
13.	149-476	1	HYD LINE	
14.	154-455	2	TEE (120)	
15.	149-448	1	HYD LINE	
16.	149-444	1	HYD LINE	
17.	149-445	1	HYD LINE	
18.	149-477	1	HYD LINE	
19.	105-818	18	BOLT (1/4-NC X 1-1/2")	
20.	110-958	4	BACKUP PLATE	
21.	110-866	4	CLAMP (1/2")	
22.	157-039	2	O-RING (014 D90)	
23.	110-411	13	BOLT-ON CLAMP (3/4", SET)	
24.	157-040	5	O-RING (016 D90)	
25.	154-312	1	REDUCER STEM (080)	
26.	154-877	1	HOSE (080FX90-90"-3000)	
27.	322-289	9	BACKUP (BOLT-ON)	
28.	107-743	8	SCREW (1/4-NC X 2.75, GD 5)	
29.	116-787	1	ABRASION SLEEVE (1.59" X 95")	
30.	154-253	1	CONNECTOR (06S-08090)	
31.	154-740	1	HOSE (080FX90S-26"-3000)	
32.	117-337	1	ABRASION SLEEVE (1.25" X 25")	
33.	117-389	1	ABRASION SLEEVE (1.25" X 104")	

FOOTNOTES

NOTES

REFER TO O-RING CHART (800-301) IN BACK OF THE BOOK FOR REPLACEMENT OF O-RINGS.

PIPE SHUTTLE HYDRAULICS

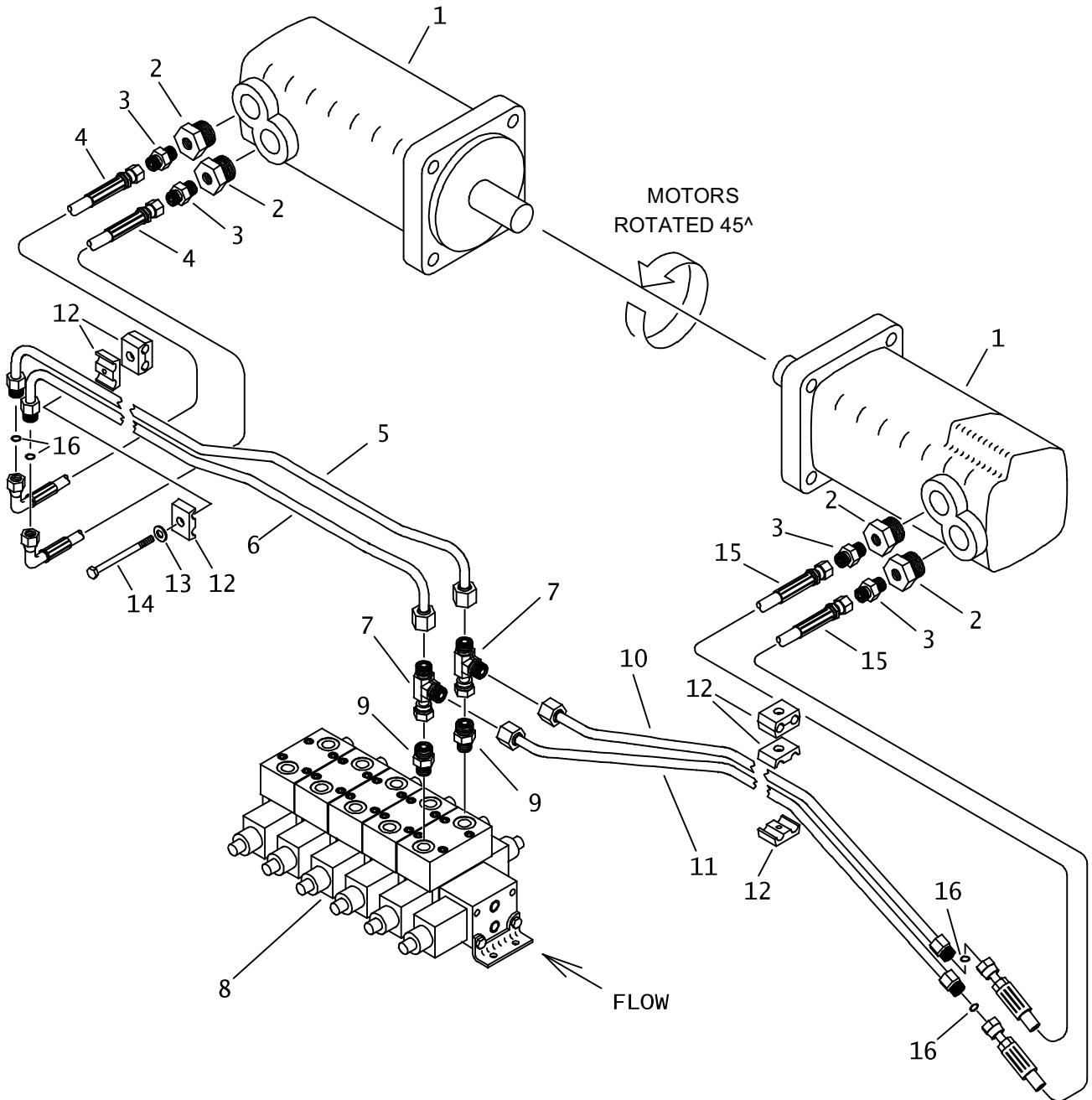

PIPE SHUTTLE HYDRAULICS

REF NO.	PART NUMBER	QTY	DESCRIPTION	REMARKS
1.	158-026	-	HYDRAULIC MOTOR (15 CU/IN)	
	500-1552	-	SEAL REPAIR KIT	
	500-1553	-	SHAFT AND BEARING KIT	
	500-711	-	SEAL REPAIR KIT-REAR	
	500-758	-	SEAL REPAIR KIT-SHAFT	
2.	155-129	4	REDUCER (12S-06SF)	
3.	154-220	4	CONNECTOR (040-06S)	
4.	515-175	2	HOSE (040FX90-16"-3000)	
5.	153-673	1	HYD LINE	TOP
6.	153-674	1	HYD LINE	BOTTOM
7.	154-344	2	UN RUN TEE (060FX-060-060)	
8.	157-764	-	HYDRAULIC VALVE	
9.	154-221	2	CONNECTOR (06S-060)	
10.	149-426	1	HYD LINE	
11.	149-959	1	HYD LINE	
12.	110-998	8	CLAMP HALVES (3/8") PAIR	
13.	105-117	5	WASHER (5/16")	
14.	105-297	5	BOLT (1/4-NC X 3-1/4")	
15.	154-800	2	HOSE (040FX-18"-3000)	SEE FOOTNOTE 1
16.	157-037	4	O-RING (011 D90)	

NOT SHOWN:

FOOTNOTES:

- I. ON MACHINES PRIOR TO RACK AND PINION, USE 155-484 TO REPLACE THIS HOSE

NOTE:

PIPE LIFTER HYDRAULICS

JT4020 ALL TERRAIN ONLY

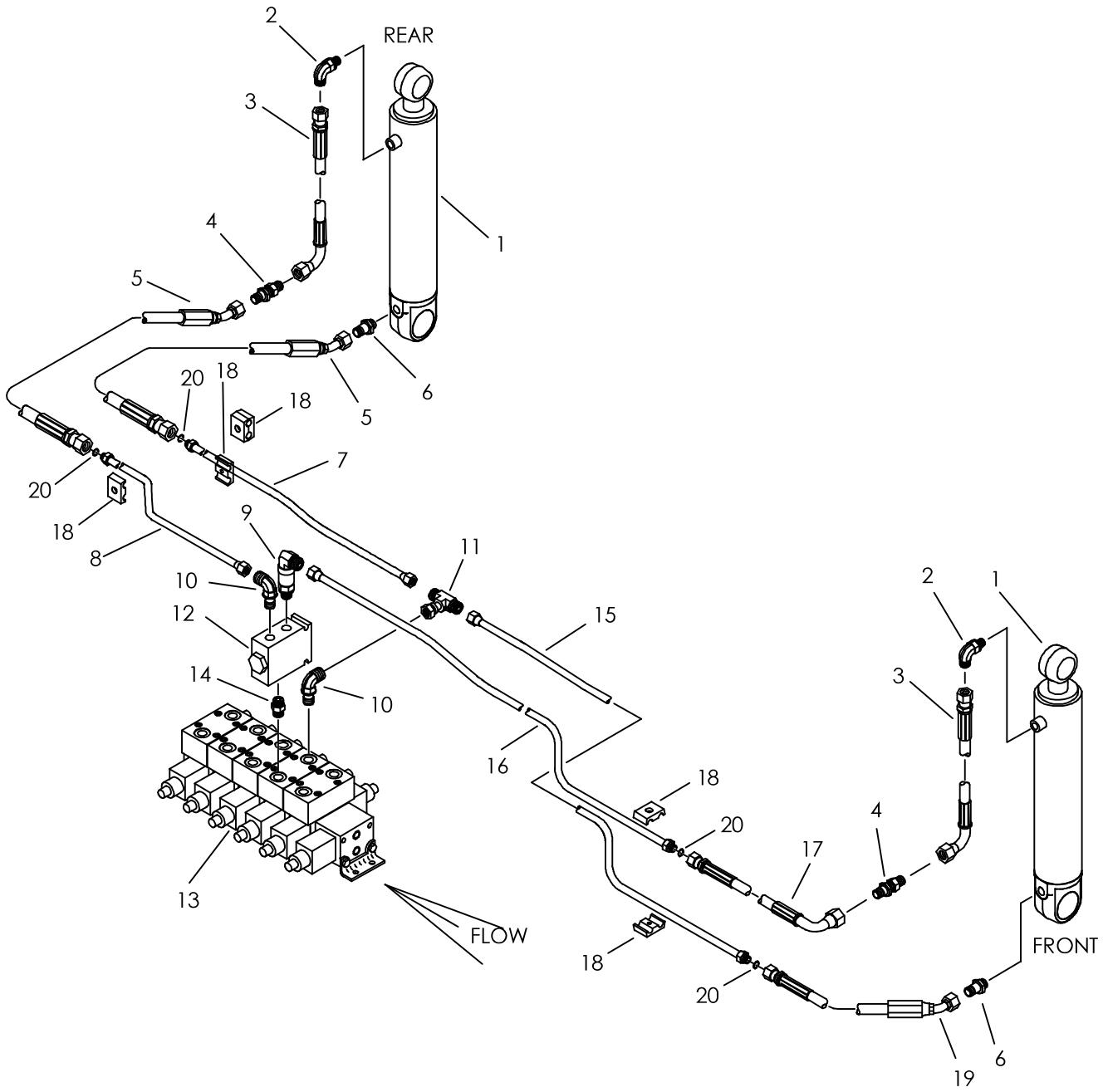

Error: No reference

Error: No reference

PIPE LIFTER HYDRAULICS

JT4020 ALL TERRAIN ONLY

REF NO.	PART NUMBER	QTY	DESCRIPTION	REMARKS
1.	151-031	2	CYL (2.0" X 1.0" X 8.0")	
2.	154-252	2	CONNECTOR (04S-04090)	
3.	515-179	2	HOSE (040FX90-11"-3000)	
4.	154-275	2	BK CONNECTOR (040-040BK)	
5.	515-072	2	HOSE (040FX45-16"-3000)	
6.	154-403	2	CONNECTOR (04S-040, XL)	
7.	153-669	1	HYD LINE	TOP
8.	153-670	1	HYD LINE	BOTTOM
9.	154-471	1	CONNECTOR (060-06S90, LG)	
10.	154-342	2	CONNECTOR (06S-06090)	
11.	154-348	1	UN BR TEE (060FX-060-060)	
12.	516-087	1	FLOW DIVIDER	
13.	157-764	1	HYDRAULIC VALVE	
14.	155-153	1	CONNECTOR (06S-06S)	
15.	149-439	1	HYD LINE	
16.	149-440	1	HYD LINE	
17.	515-175	1	HOSE (040FX90-16"-3000)	
18.	110-998	7	CLAMP HALVES (3/8") PAIR	
19.	154-934	1	HOSE (040FX45-18"-3000)	
20.	157-037	4	O-RING (011 D90)	

NOT SHOWN:

FOOTNOTES:

NOTE:

GRIPPER HYDRAULICS

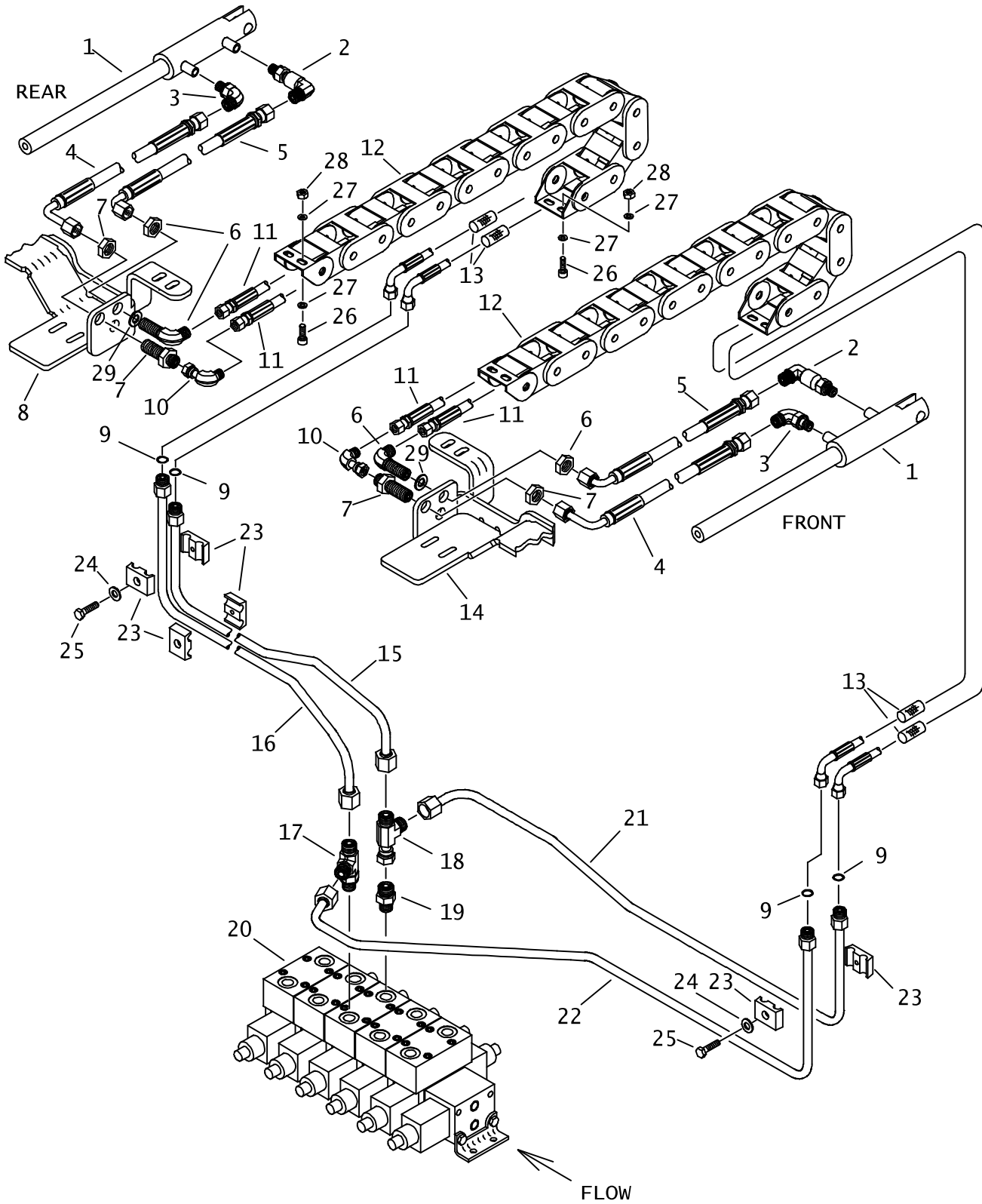

GRIPPER HYDRAULICS

1.	150-731	2	CYL ASS'Y	
2.	154-474	2	CONNECTOR (04S-04090,XL)	
3.	154-252	2	CONNECTOR (04S-04090)	
4.	157-362	2	HOSE (040FX90L-11"-3000)	
5.	515-598	2	HOSE (040FX90-12"-3000)	
6.	154-355	2	BK CONNECTOR (040-04090BK)	
7.	154-275	2	BK CONNECTOR (040-040BK)	
8.	313-684	-	REAR SHUTTLE	
9.	157-037	4	O-RING (011 D90)	
10.	154-255	2	UNION (040-040FX90)	
11.	153-365	4	HOSE (040FX90S-34"-3000)	
12.	306-746	2	HOSE TRACK	
13.	117-412	4	ABRASION SLEEVE (1.25" X 34")	
14.	313-683	-	FRONT SHUTTLE	
15.	153-671	1	HYD LINE	TOP
16.	153-672	1	HYD LINE	BOTTOM
17.	153-667	1	SPECIAL TEE (06S,ORF-060-060)	
18.	154-344	1	UN RUN TEE (060FX-060-060)	
19.	156-067	1	CONNECTOR (06S-060, ORF .031")	
20.	157-764	-	HYDRAULIC VALVE	
21.	149-427	1	HYD LINE	TOP
22.	149-428	1	HYD LINE	BOTTOM
23.	110-998	6	CLAMP HALVES (3/8") PAIR	
24.	105-117	2	WASHER (5/16")	
25.	105-197	2	BOLT (1/4-NC X 1")	
26.	106-640	8	SCREW (M6-1.00 X 20MM, BUT SOC)	
27.	105-284	16	WASHER (3/16")	
28.	106-237	8	LOCKNUT (M6-1.00,PRV TRQ,NLK)	
29.	106-598	2	WASHER (9/16" HARDENED)	

GREASER HYDRAULICS

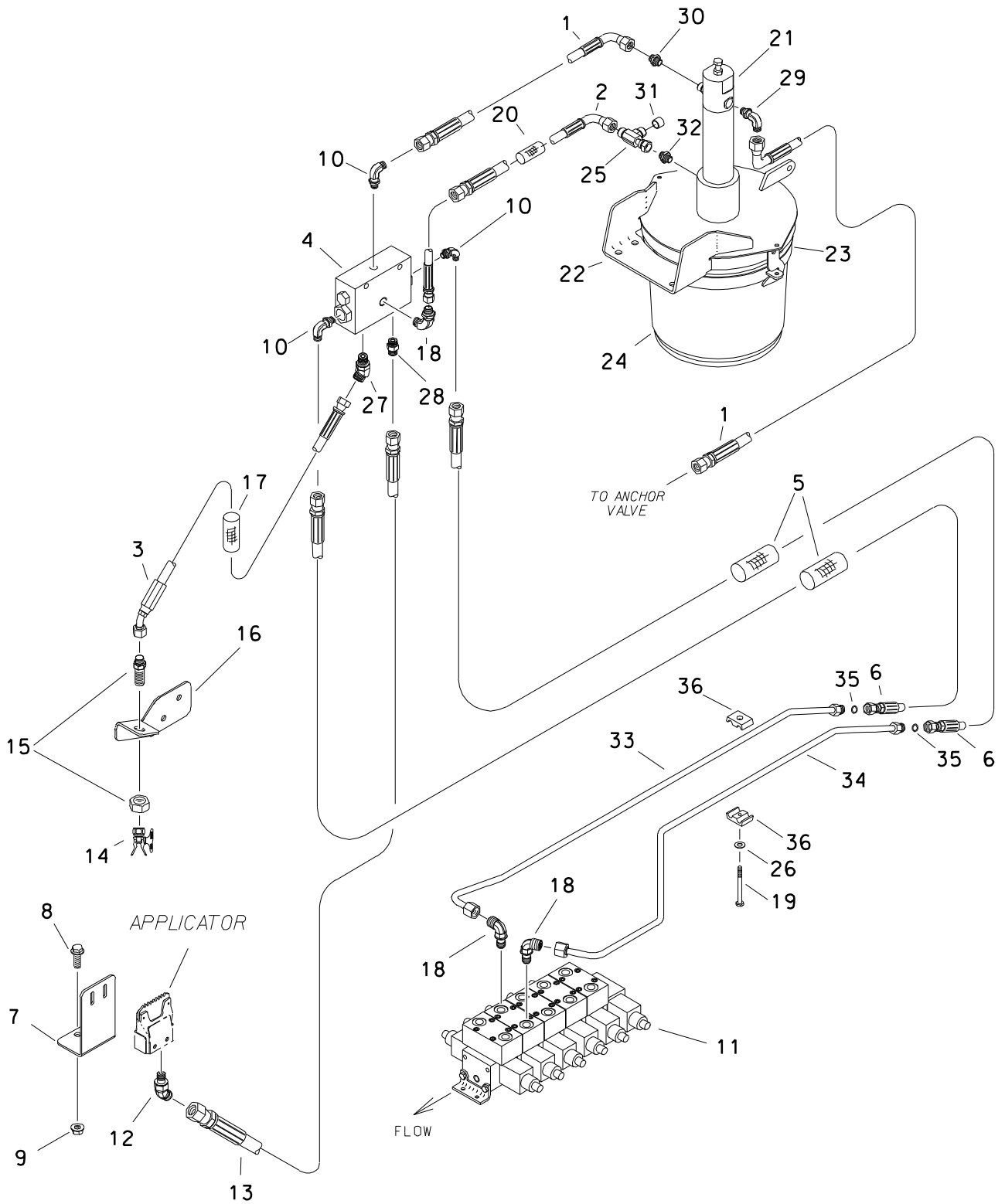

GREASER HYDRAULICS

REF NO.	PART NUMBER	QTY	DESCRIPTION	REMARKS
1.	149-827	2	HOSE (040FX90S-24"-3000)	
2.	153-320	1	HOSE (060FX90L-17"-3000)	
3.	149-825	1	HOSE (060FX90L-28"-3000)	
4.	310-591	1	VALVE ASS'Y	SEE FOOTNOTE 3
5.	117-211	2	ABRASION SLEEVE (1.25" X 90")	
6.	154-724	2	HOSE (040FX-82"-3000)	
7.	318-607	1	BRACKET, WIPER	SEE FOOTNOTE 4
8.	106-724	2	FLG SCREW (M10-1.50 X 25MM)	
9.	106-387	2	FLG LOCKNUT (M10-1.50)	
10.	154-252	3	CONNECTOR (04S-04090)	
11.	157-764	-	HYDRAULIC VALVE	SEE FOOTNOTE 3
12.	514-414	1	CONNECTOR (04S-06045)	
13.	153-424	1	HOSE (060FX-236"-3000)	
14.	401-155	1	SPRAY NOZZLE	
	191-258	1	SPRAY NOZZLE HANDLE KIT	
	153-096	1	CAP GASKET, NYLON	
15.	514-163	1	BK CONNECTOR (060-060BK)	
16.	318-854	-	BRACKET, SPRAY	
17.	117-684	1	ABRASION SLEEVE (1.00" X 26")	
18.	154-342	3	CONNECTOR (06S-06090)	
19.	105-297	1	BOLT (1/4-NC X 3-1/4")	
20.	117-194	1	ABRASION SLEEVE (1.00" X 16")	
21.	350-398	-	GREASE PUMP	
22.	350-400	-	COVER	
23.	350-399	-	BASE	
24.	259-858	-	TOOL JNT LUBE, STD SPRY 2 GAL	
	256-031	-	TOOL JNT LUBE, SUMR SPRY 2 GAL	
25.	154-344	1	UN RUN TEE (060FX-060-060)	
26.	105-117	1	WASHER (5/16")	
27.	154-224	1	CONNECTOR (06S-06045)	SEE FOOTNOTE 1
28.	514-165	1	CONNECTOR (06S-060, ORF .078")	SEE FOOTNOTE 2
29.	154-401	1	CONNECTOR (04S-04090, ORF)	
30.	154-278	1	CONNECTOR (04S-040)	
31.	154-326	1	CAP (060F)	
32.	154-221	1	CONNECTOR (06S-060)	
33.	149-956	1	HYD LINE	
34.	149-957	1	HYD LINE	
35.	157-037	2	O-RING (011 D90)	
36.	110-998	1	CLAMP HALVES (3/8") PAIR	

FOOTNOTES

1. TO SPRAY NOZZEL.
2. TO REAR APPLICATOR.
3. FOR PARTS BREAKDOWN OF SELECTOR VALVE & APPLICATOR, SEE SPECIFIC PARTS PAGES.
4. USE SCREWS WITH APPLICATOR TO ATTACH TO BRACKET.

NOTE

REFER TO O-RING CHART (800-301) ON BACK OF THE BOOK FOR REPLACEMENT OF O-RINGS.

SEAT ROTATION HYDRAULICS

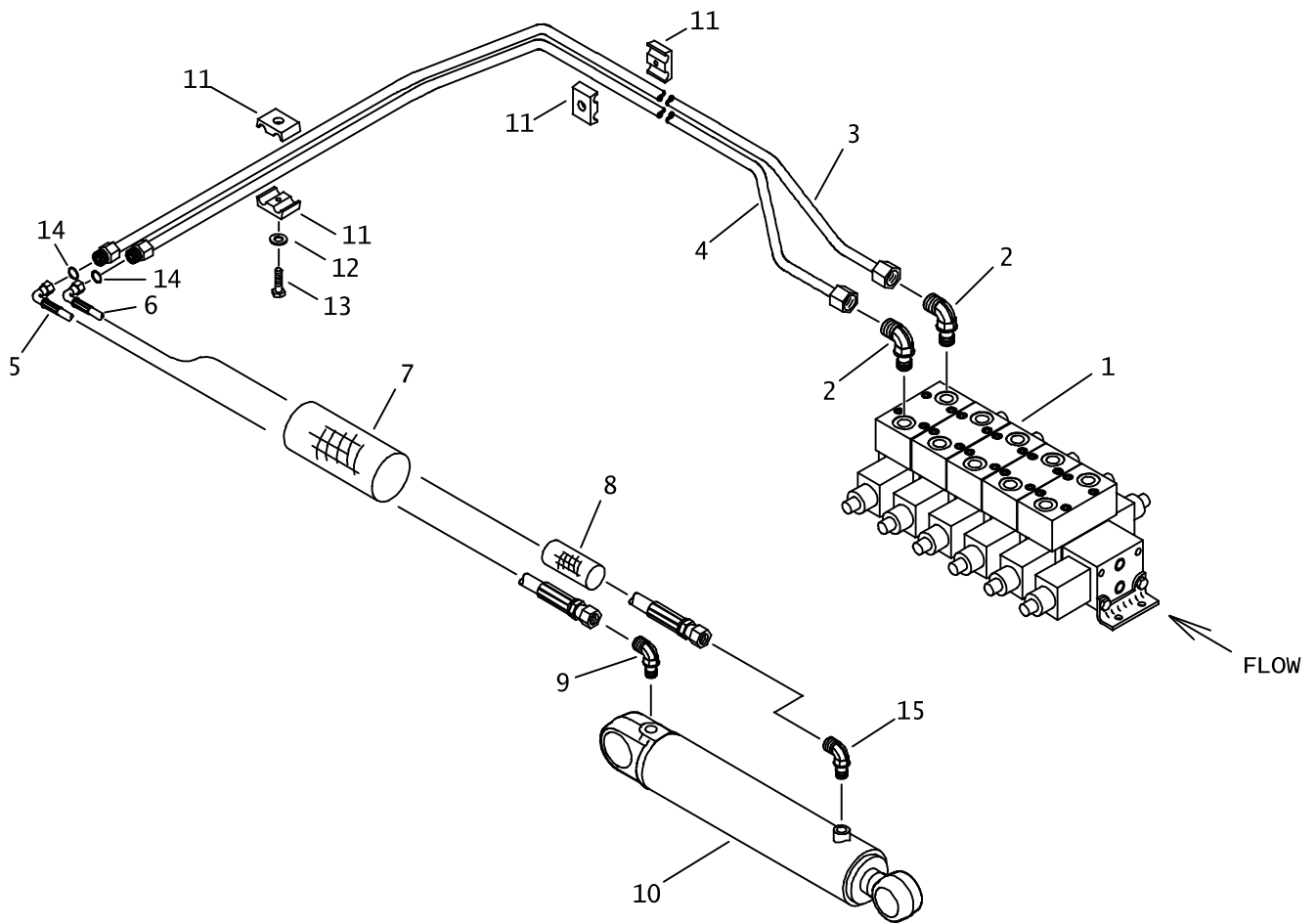

SEAT ROTATION HYDRAULICS

REF NO.	PART NUMBER	QTY	DESCRIPTION	REMARKS
1.	157-764	-	HYDRAULIC VALVE	
2.	154-342	2	CONNECTOR (06S-06090)	
3.	149-450	1	HYD LINE	TOP
4.	149-451	1	HYD LINE	BOTTOM
5.	515-203	1	HOSE (040FX90-135"-3000)	
6.	515-146	1	HOSE (040FX90S-140"-3000)	
7.	117-619	1	ABRASION SLEEVE (1.59" X 135")	
8.	117-671	1	ABRASION SLEEVE (1.00" X 12")	
9.	154-401	1	CONNECTOR (04S-04090, ORF)	
10.	151-031	1	CYL (2.0" X 1.0" X 8.0")	
11.	110-998	5	CLAMP HALVES (3/8") PAIR	
12.	105-117	1	WASHER (5/16")	
13.	105-197	1	BOLT (1/4-NC X 1")	
14.	157-037	2	O-RING (011 D90)	
15.	154-252	1	CONNECTOR (04S-04090)	

NOT SHOWN:

FOOTNOTES:

NOTE:

REFER TO O-RING CHART (800-301) IN BACK OF THE BOOK FOR REPLACEMENT OF O-RINGS.

HYDRAULIC CYLINDERS (2.0" X 1.0")

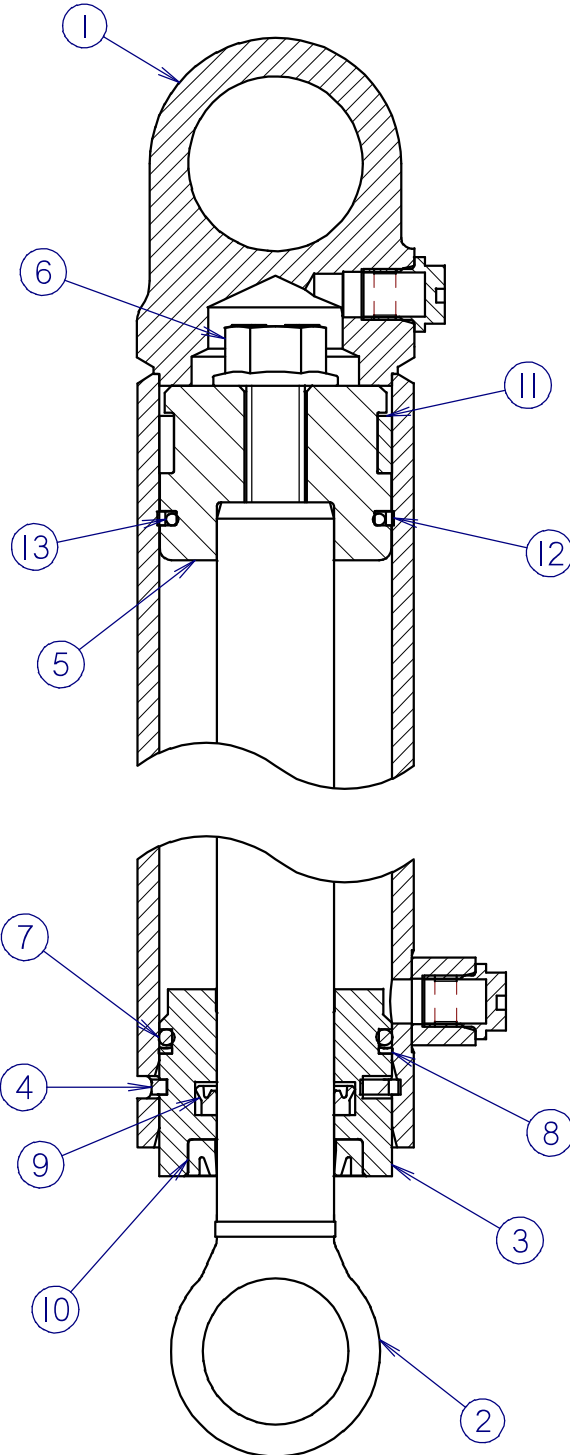

HYDRAULIC CYLINDERS (2.0" X 1.0")

REF NO.	PART NUMBER	QTY	DESCRIPTION	REMARKS
	151-094	-	CYL (2.0 X 1.0 X 2.0)	SEE FOOTNOTES 1 & 2
1	152-029	1	CYLINDER BARREL (2.0 X 2.0)	
2	153-007	1	CYLINDER ROD (1.00 X 2.0)	
	149-667	-	CYL (2.0 X 1.0 X 2.5)	SEE FOOTNOTES 1 & 2
1	149-761	1	CYLINDER BARREL (2.0 X 2.5)	
2	149-728	1	CYLINDER ROD (1.00 X 2.5)	
	151-027	-	CYL (2.0 X 1.0 X 3.0)	SEE FOOTNOTES 1 & 2
1	150-282	1	CYLINDER BARREL (2.0 X 3.0)	
2	150-414	1	CYLINDER ROD (1.00 X 3.0)	
	151-038	-	CYL (2.0 X 1.0 X 4.0)	SEE FOOTNOTES 1 & 2
1	150-290	1	CYLINDER BARREL (2.0 X 4.0)	
2	150-421	1	CYLINDER ROD (1.00 X 4.0)	
	151-039	-	CYL (2.0 X 1.0 X 5.0)	SEE FOOTNOTES 1 & 2
1	150-291	1	CYLINDER BARREL (2.0 X 5.0)	
2	150-422	1	CYLINDER ROD (1.00 X 5.0)	
	151-044	-	CYL (2.0 X 1.0 X 6.0)	SEE FOOTNOTES 1 & 2
1	150-294	1	CYLINDER BARREL (2.0 X 6.0)	
2	150-424	1	CYLINDER ROD (1.00 X 6.0)	
	151-031	-	CYL (2.0 X 1.0 X 8.0)	SEE FOOTNOTES 1 & 2
1	150-285	1	CYLINDER BARREL (2.0 X 8.0)	
2	150-417	1	CYLINDER ROD (1.00 X 8.0)	
	151-076	-	CYL (2.0 X 1.0 X 10.0)	SEE FOOTNOTES 1 & 2
1	152-017	1	CYLINDER BARREL (2.0 X 10.0)	
2	150-444	1	CYLINDER ROD (1.00 X 10.0)	
	149-668	-	CYL (2.0 X 1.0 X 12.0)	SEE FOOTNOTES 1 & 2
1	150-286	1	CYLINDER BARREL (2.0 X 12.0)	
2	149-729	1	CYLINDER ROD (1.00 X 12.0)	
3	150-772	1	CYLINDER HEAD (2.0 X 1.00)	
4	150-778	1	LOCK RING (2.0)	
5	150-775	1	CYLINDER PISTON (2.0 X 1.00)	
6	106-096	1	FLG BOLT (1/2-NC X 1-3/4",GD8)	SEE FOOTNOTE 3
7	157-022	1	O-RING (224 D90)	
8	155-732	1	BACKUP RING (224 D90)	
9	157-540	1	U-SEAL (1.000")	
10	157-537	1	WIPER SEAL (1.000")	
11	125-774	1	WEAR RING	
12	157-534	1	BACKUP RING (131 D90)	
13	157-018	1	O-RING (131 D90)	

NOT SHOWN:

259-100	U-SEAL INSTALLER (1" - 1.499")
259-235	1.00 ROD WIPER TOOL
259-239	WIPER/SEAL INSTALLER (2")
259-241	PISTON INSTALLER (2")
259-188	CYL HEAD SPANNER - TWO PIN

FOOTNOTES:

- REF. #1 & #2 ARE SPECIFIC TO EACH CYLINDER, REF. #3 THRU #13 ARE COMMON FOR ALL THE ABOVE LISTED CYLINDERS
- SEAL REPAIR KIT P/N: 190-165
- APPLY LOCTITE 277 OR EQUIVALENT, TORQUE TO 90-100 FT-LBS

NOTE:

HYDRAULIC CYLINDER

2.0" X 1.25" X 24.0"

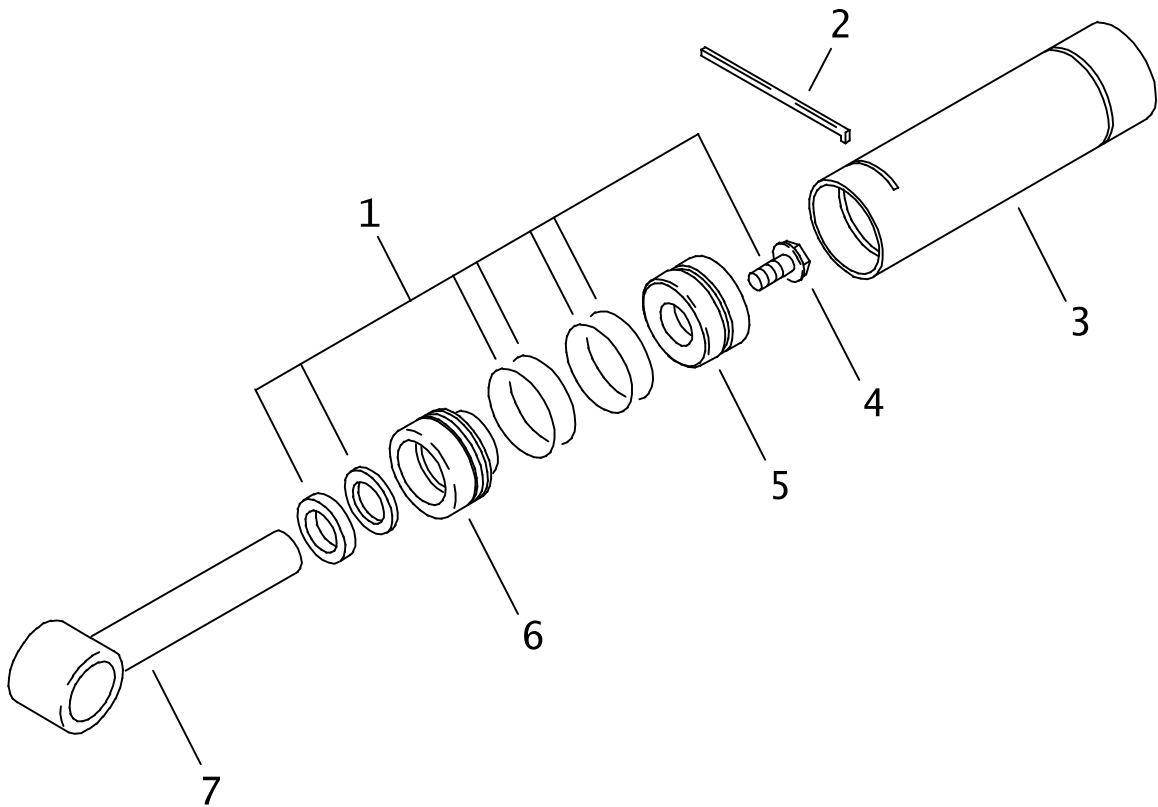

HYDRAULIC CYLINDER

2.0" X 1.25" X 24.0"

REF NO.	PART NUMBER	QTY	DESCRIPTION	REMARKS
	150-747		CYL (2" X 1.25" X 24")	INCLUDE REF NO'S 1 THRU 7
1.	190-169	1	SEAL REPAIR KIT (2.0" X 1.25")	INCLUDES REF NO'S 4 & 5
2.	150-778	1	LOCK RING (2")	
3.	151-170	1	CYLINDER BARREL	
4.	106-097	1	FLG BOLT (5/8-NC X 1-3/4", GD8)	SEE FOOTNOTE 1
5.	150-771	1	CYLINDER PISTON (2.0" X 1.25")	INCLUDES MOLDED-ON WEAR RING
6.	150-770	1	CYLINDER HEAD (2.0" X 1.25")	
7.	150-679	1	CYLINDER ROD (1.25")	

NOT SHOWN:

259-100	U-SEAL INSTALLER (1"-1.499")
259-236	WIPER INSTALLER (1.250")
259-239	WIPER/SEAL INSTALLER (2")
259-241	PISTON INSTALLER (2")
259-188	CYL HEAD SPANNER - TWO PIN

FOOTNOTES

1. APPLY LOCTITE 271 OR 277. TORQUE TO 180-200 FT-LBS (245-270 N.M.)

NOTE:

D

806-687

HYDRAULIC CYLINDERS (3.0" X 1.75")

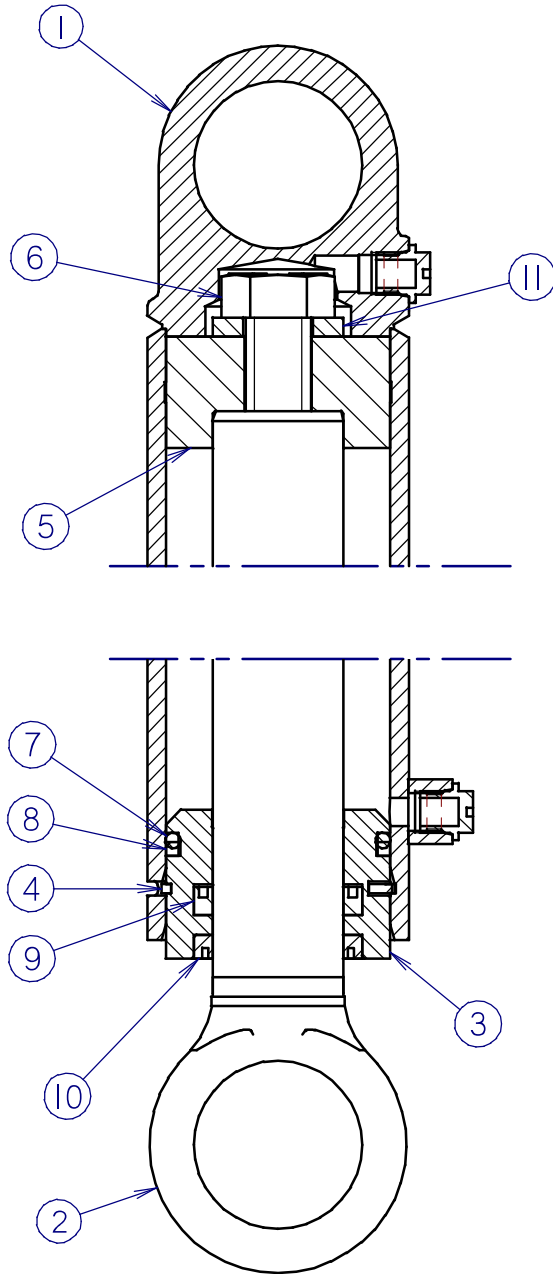

HYDRAULIC CYLINDERS (3.0" X 1.75")

REF NO.	PART NUMBER	QTY	DESCRIPTION	REMARKS
	149-683	-	CYL (3.0 X 1.75 X 3.0)	SEE FOOTNOTES 1 & 2
1	150-299	1	CYLINDER BARREL (3.0 X 3.0)	
2	150-446	1	CYLINDER ROD (1.75 X 3.0)	
	149-684	-	CYL (3.0 X 1.75 X 4.0)	SEE FOOTNOTES 1 & 2
1	152-004	1	CYLINDER BARREL (3.0 X 4.0)	
2	153-015	1	CYLINDER ROD (1.75 X 4.0)	
	149-685	-	CYL (3.0 X 1.75 X 5.0)	SEE FOOTNOTES 1 & 2
1	152-068	1	CYLINDER BARREL (3.0 X 5.0)	
2	150-432	1	CYLINDER ROD (1.75 X 5.0)	
	151-058	-	CYL (3.0 X 1.75 X 6.0)	SEE FOOTNOTES 1 & 2
1	152-008	1	CYLINDER BARREL (3.0 X 6.0)	
2	150-428	1	CYLINDER ROD (1.75 X 6.0)	
	151-070	-	CYL (3.0 X 1.75 X 8.0)	SEE FOOTNOTES 1 & 2
1	152-014	1	CYLINDER BARREL (3.0 X 8.0)	
2	150-436	1	CYLINDER ROD (1.75 X 8.0)	
	149-686	-	CYL (3.0 X 1.75 X 10.0)	SEE FOOTNOTES 1 & 2
1	150-284	1	CYLINDER BARREL (3.0 X 10.0)	
2	149-732	1	CYLINDER ROD (1.75 X 10.0)	
	151-042	-	CYL (3.0 X 1.75 X 12.0)	SEE FOOTNOTES 1 & 2
1	150-293	1	CYLINDER BARREL (3.0 X 12.0)	
2	150-425	1	CYLINDER ROD (1.75 X 12.0)	
	151-083	-	CYL (3.0 X 1.75 X 16.0)	SEE FOOTNOTES 1 & 2
1	150-288	1	CYLINDER BARREL (3.0 X 16.0)	
2	153-004	1	CYLINDER ROD (1.75 X 16.0)	
	151-122	-	CYL (3.0 X 1.75 X 20.0)	SEE FOOTNOTES 1 & 2
1	150-667	1	CYLINDER BARREL (3.0 X 20.0)	
2	153-020	1	CYLINDER ROD (1.75 X 20.0)	
	149-687	-	CYL (3.0 X 1.75 X 24.0)	SEE FOOTNOTES 1 & 2
1	149-763	1	CYLINDER BARREL (3.0 X 24.0)	
2	149-733	1	CYLINDER ROD (1.75 X 24.0)	
	149-688	-	CYL (3.0 X 1.75 X 30.0)	SEE FOOTNOTES 1 & 2
1	149-764	1	CYLINDER BARREL (3.0 X 30.0)	
2	149-734	1	CYLINDER ROD (1.75 X 30.0)	
3	150-763	1	CYLINDER HEAD (3.0 X 1.75)	
4	150-911	1	LOCK RING (3.0)	
5	150-765	1	CYLINDER PISTON (3.0 X 1.75)	INCL. MOLDED-ON WEAR RING
6	106-122	1	BOLT (7/8-NC X 2-1/4", GD8)	SEE FOOTNOTE 3
7	155-734	1	O-RING (334 D90)	
8	155-733	1	BACKUP RING (334 D90)	
9	157-550	1	U-SEAL (1.750")	
10	157-549	1	WIPER SEAL (1.750")	
11	105-363	1	WASHER (7/8")	

FOOTNOTES

- REF. #1 & #2 ARE SPECIFIC TO EACH CYLINDER, REF. #3 THRU #11 ARE COMMON FOR ALL THE ABOVE LISTED CYLINDERS.
- SEAL REPAIR KIT P/N: 190-172
- APPLY LOCTITE 277 OR EQUIVALENT, TORQUE TO 410-460 FT-LBS

NOT SHOWN:

- 259-040 U-SEAL INSTALLER (1.5" - UP)
- 259-238 WIPER INSTALLER (1.75")
- 259-244 PISTON SEAL INSTALLER (3.5")
- 259-245 PISTON INSTALLER (3.5")
- 259-188 CYL HEAD SPANNER - TWO PIN

A

809-366

HYDRAULIC CYLINDERS (4.0" X 2.0")

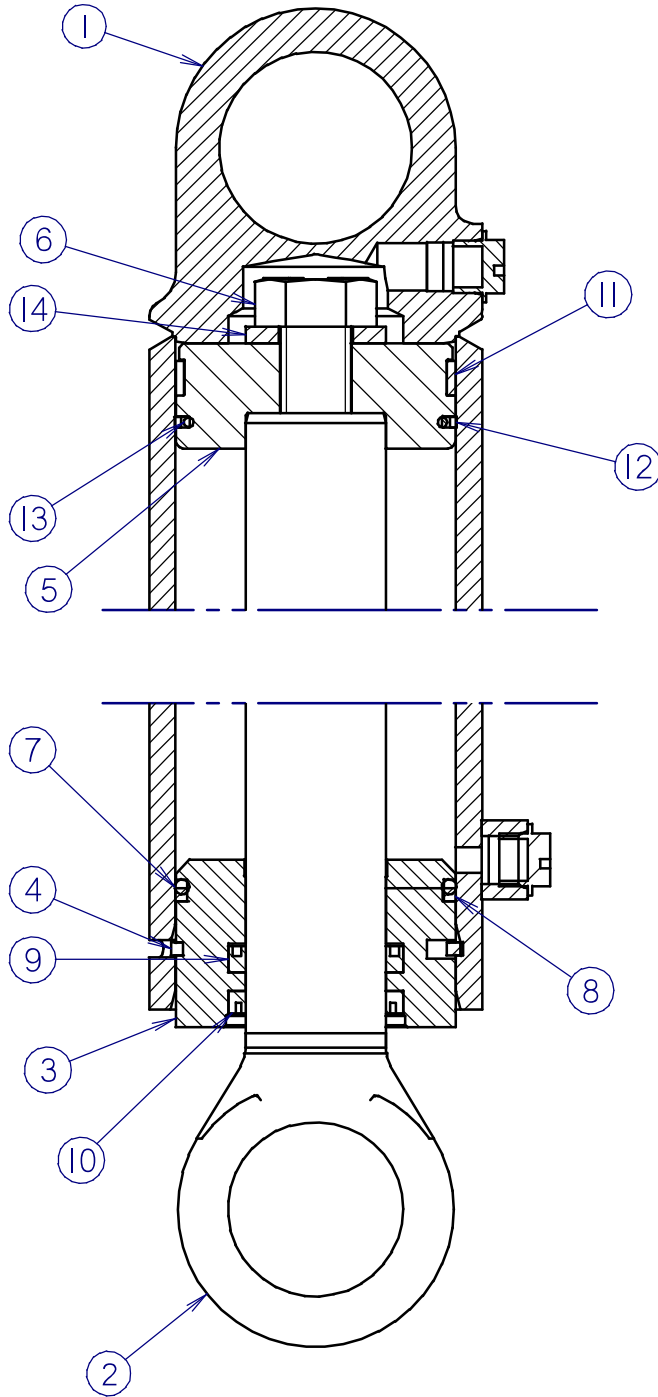

HYDRAULIC CYLINDERS (4.0" X 2.0")

REF NO.	PART NUMBER	QTY	DESCRIPTION	REMARKS
	149-698	-	CYL (4.0 X 2.0 X 4.0)	SEE FOOTNOTES 1 & 2
1	149-768	1	CYLINDER BARREL (4.0 X 4.0)	
2	153-021	1	CYLINDER ROD (2.00 X 4.0)	
	151-066	-	CYL (4.0 X 2.0 X 5.0)	SEE FOOTNOTES 1 & 2
1	152-012	1	CYLINDER BARREL (4.0 X 5.0)	
2	150-440	1	CYLINDER ROD (2.00 X 5.0)	
	149-699	-	CYL (4.0 X 2.0 X 6.0)	SEE FOOTNOTES 1 & 2
1	152-062	1	CYLINDER BARREL (4.0 X 6.0)	
2	149-735	1	CYLINDER ROD (2.00 X 6.0)	
	149-700	-	CYL (4.0 X 2.0 X 8.0)	SEE FOOTNOTES 1 & 2
1	152-030	1	CYLINDER BARREL (4.0 X 8.0)	
2	149-736	1	CYLINDER ROD (2.00 X 8.0)	
	149-701	-	CYL (4.0 X 2.0 X 10.0)	SEE FOOTNOTES 1 & 2
1	149-769	1	CYLINDER BARREL (4.0 X 10.0)	
2	153-016	1	CYLINDER ROD (2.00 X 10.0)	
	151-088	-	CYL (4.0 X 2.0 X 12.0)	SEE FOOTNOTES 1 & 2
1	150-298	1	CYLINDER BARREL (4.0 X 12.0)	
2	150-429	1	CYLINDER ROD (2.00 X 12.0)	
	149-702	-	CYL (4.0 X 2.0 X 16.0)	SEE FOOTNOTES 1 & 2
1	152-007	1	CYLINDER BARREL (4.0 X 16.0)	
2	149-737	1	CYLINDER ROD (2.00 X 16.0)	
	149-703	-	CYL (4.0 X 2.0 X 20.0)	SEE FOOTNOTES 1 & 2
1	149-770	1	CYLINDER BARREL (4.0 X 20.0)	
2	149-738	1	CYLINDER ROD (2.00 X 20.0)	
	149-704	-	CYL (4.0 X 2.0 X 24.0)	SEE FOOTNOTES 1 & 2
1	152-063	1	CYLINDER BARREL (4.0 X 24.0)	
2	149-739	1	CYLINDER ROD (2.00 X 24.0)	
3	149-006	1	CYLINDER HEAD (4.0 X 2.00)	
4	149-303	1	LOCK RING (4.0)	
5	149-307	1	CYLINDER PISTON (4.0 X 2.00)	
6	106-145	1	BOLT (1-NC X 2-1/4", GD8)	SEE FOOTNOTE 3
7	157-035	1	O-RING (342 D90)	
8	157-036	1	BACKUP RING (342 D90)	
9	157-559	1	U-SEAL (2.000")	
10	157-558	1	WIPER SEAL (2.000")	
11	125-793	1	WEAR RING	
12	157-570	1	BACKUP RING (238 D90)	
13	157-044	1	O-RING (238 D90)	
14	106-144	1	WASHER (1")	

FOOTNOTES

- REF. #1 & #2 ARE SPECIFIC TO EACH CYLINDER, REF. #3 THRU #14 ARE COMMON FOR ALL THE ABOVE LISTED CYLINDERS.
- SEAL REPAIR KIT P/N: 190-189
- APPLY LOCTITE 277 OR EQUIVALENT, TORQUE TO 630-700 FT-LBS

NOT SHOWN:

- 259-040 U-SEAL INSTALLER (1.5" - UP)
- 259-239 WIPER/SEAL INSTALLER (2")
- 259-246 PISTON SEAL INSTALLER (4")
- 259-247 PISTON INSTALLER (4")
- 259-188 CYL HEAD SPANNER - TWO PIN

A

809-369

HYDRAULIC CYLINDER (4.0" X 2.00" X 10.0")

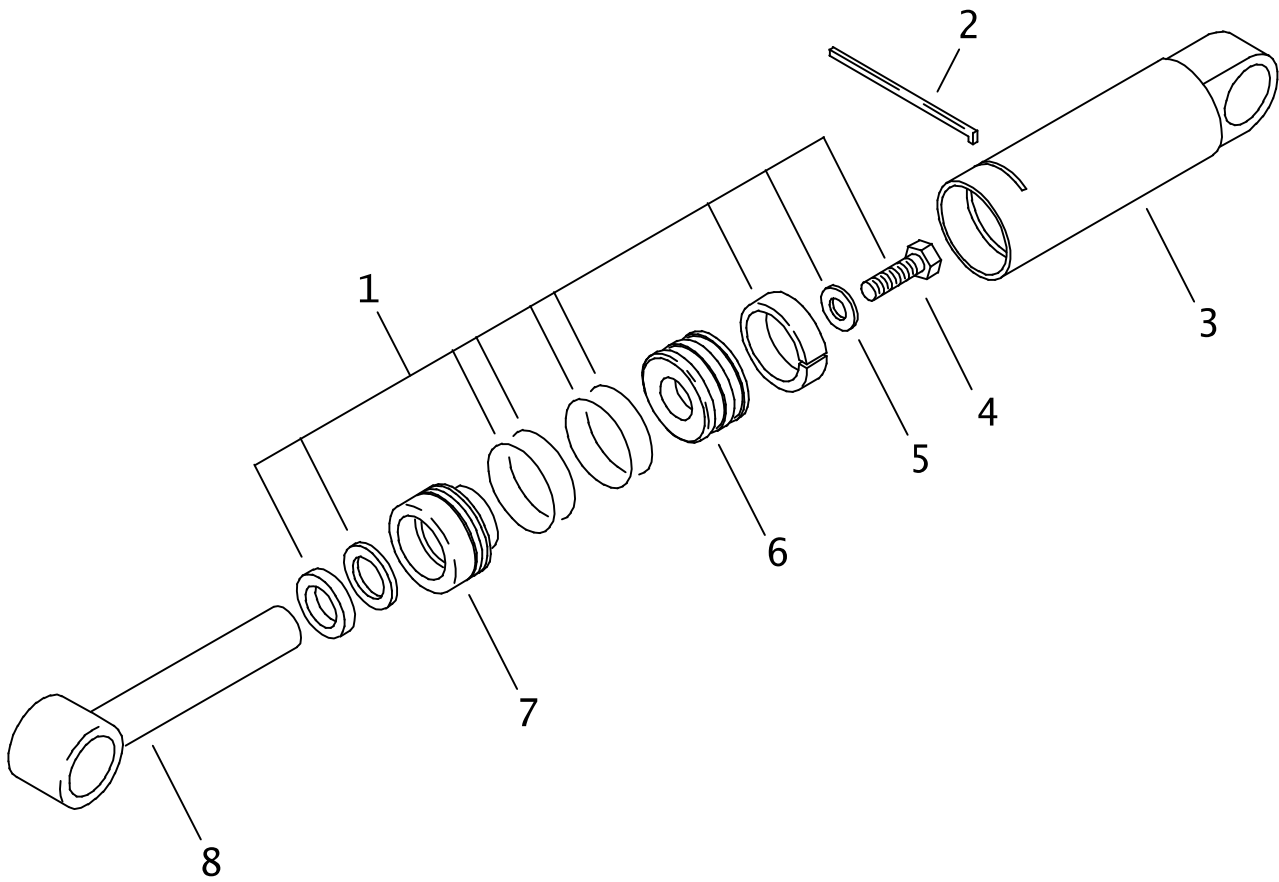

HYDRAULIC CYLINDER (4.0" X 2.00" X 10.0")

REF NO.	PART NUMBER	QTY	DESCRIPTION	REMARKS
	151-187		CYLINDER ASSEMBLY	INCLUDES REF NO.'S 1 THRU 7
1.	190-189	1	SEAL REPAIR KIT (4.0" X 2.0")	INCLUDES REF. NO.'S 4 & 5
2.	149-303	1	LOCK RING (4")	
3.	152-071	1	CYLINDER BARREL	
4.	106-145	1	BOLT (1-NC X 2-1/4", GD8)	SEE FOOTNOTE 1
5.	106-144	1	WASHER (1")	
6.	149-307	1	CYLINDER PISTON (4" X 2")	
7.	149-006	1	CYLINDER HEAD (4" X 2")	
8.	153-016	1	CYLINDER ROD	

NOT SHOWN:

259-040	U-SEAL INSTALLER (1.500"-UP)
259-239	WIPER/SEAL INSTALLER (2")
259-246	PISTON SEAL INSTALLER (4")
259-247	PISTON INSTALLER (4")
259-188	CYL HEAD SPANNER - TWO PIN

FOOTNOTES

1 APPLY LOCTITE 271 OR 277. TORQUE TO 630-700 FT-LBS (855-950 NM)

NOTE:

D

806-688

NOTES:

ELECTRICAL

ELECTRICAL SCHEMATIC JT4020 ALL TERRAIN

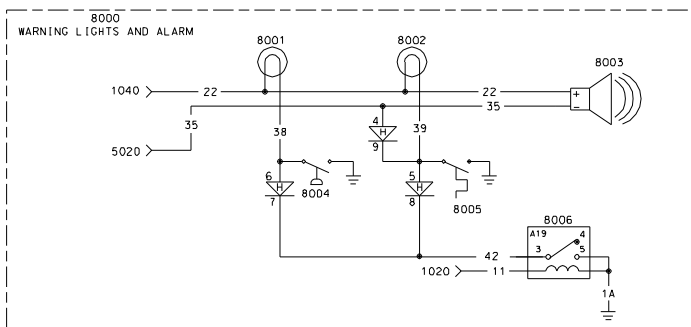
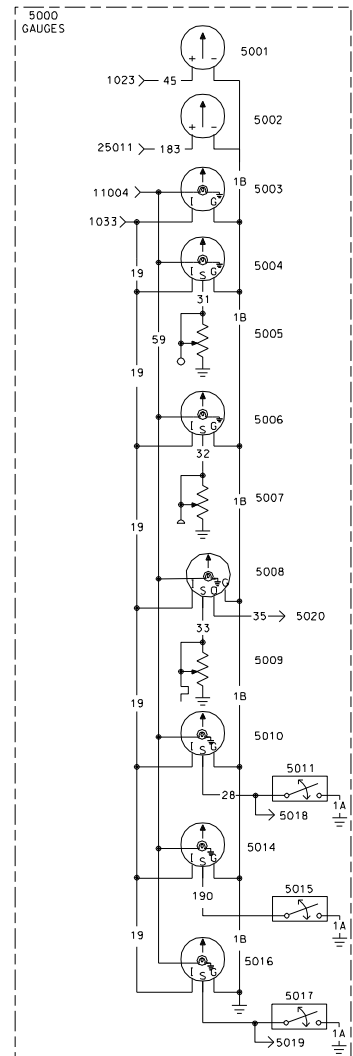
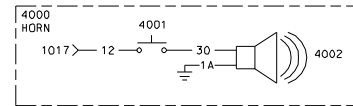
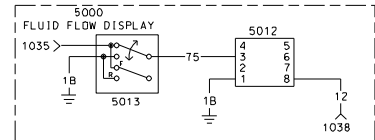
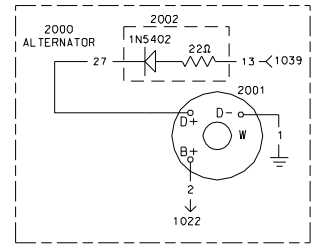
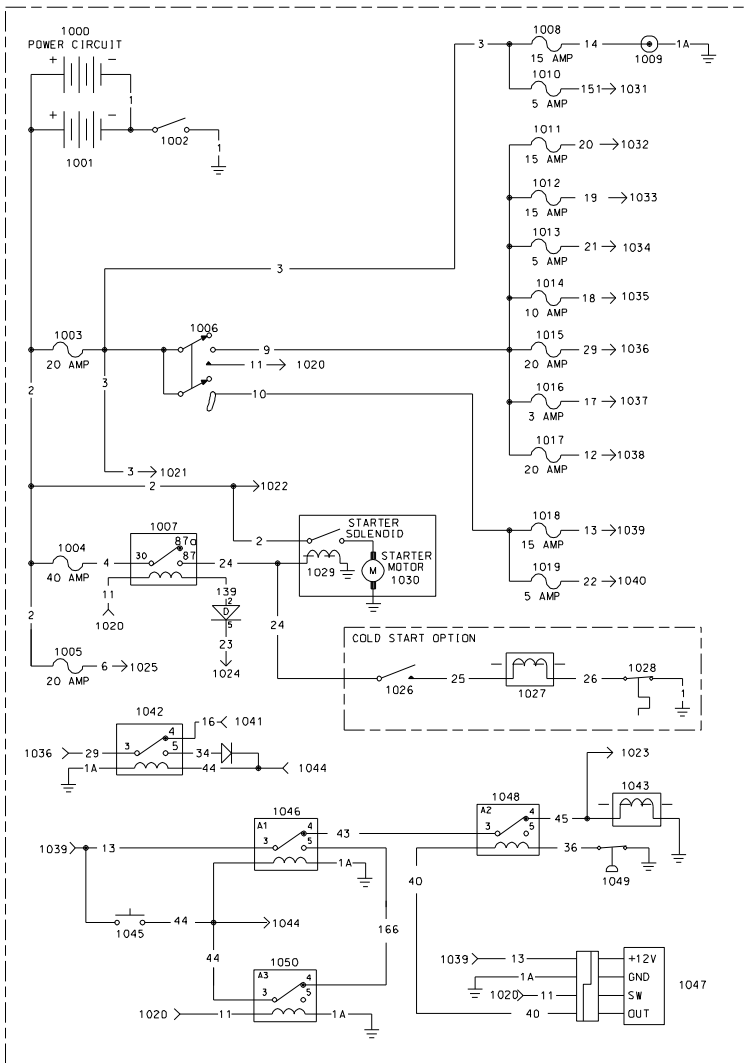

ELECTRICAL SCHEMATIC JT4020 ALL TERRAIN

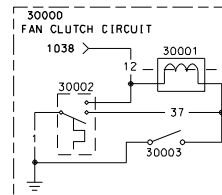
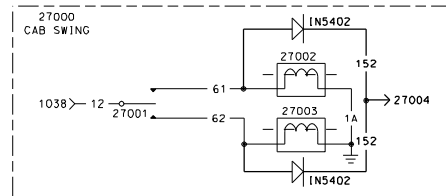
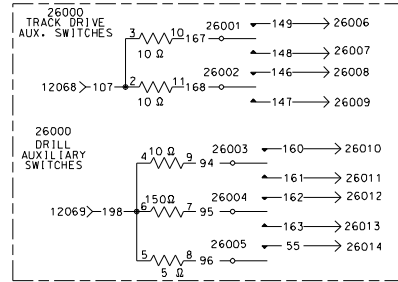
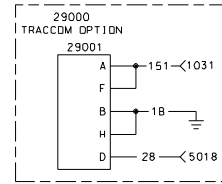
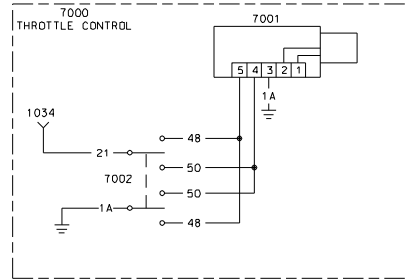
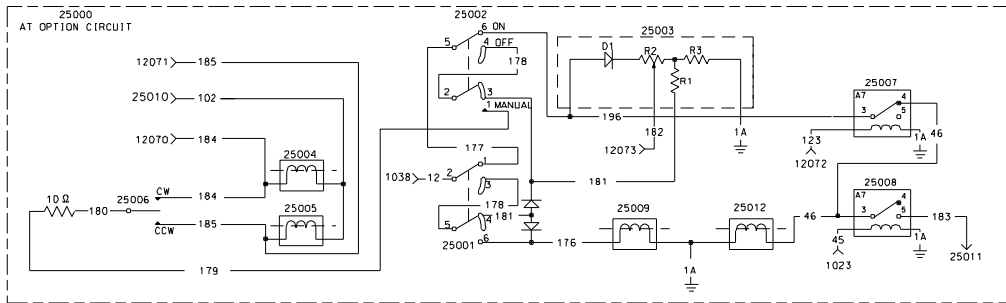
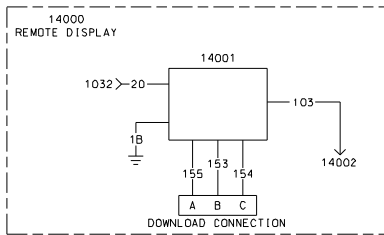
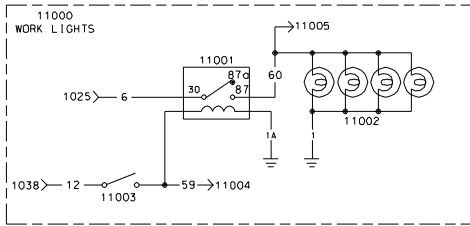
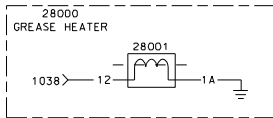
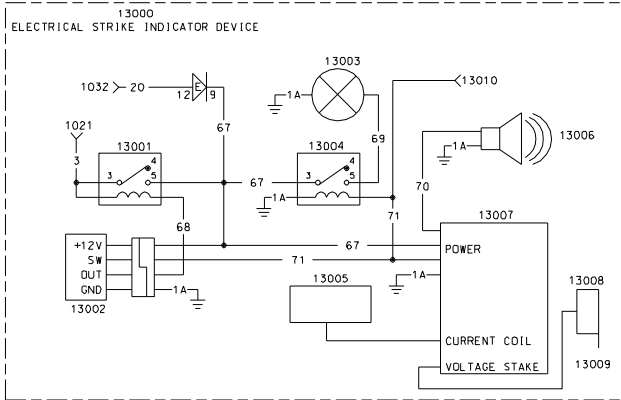

ELECTRICAL SCHEMATIC JT4020 ALL TERRAIN

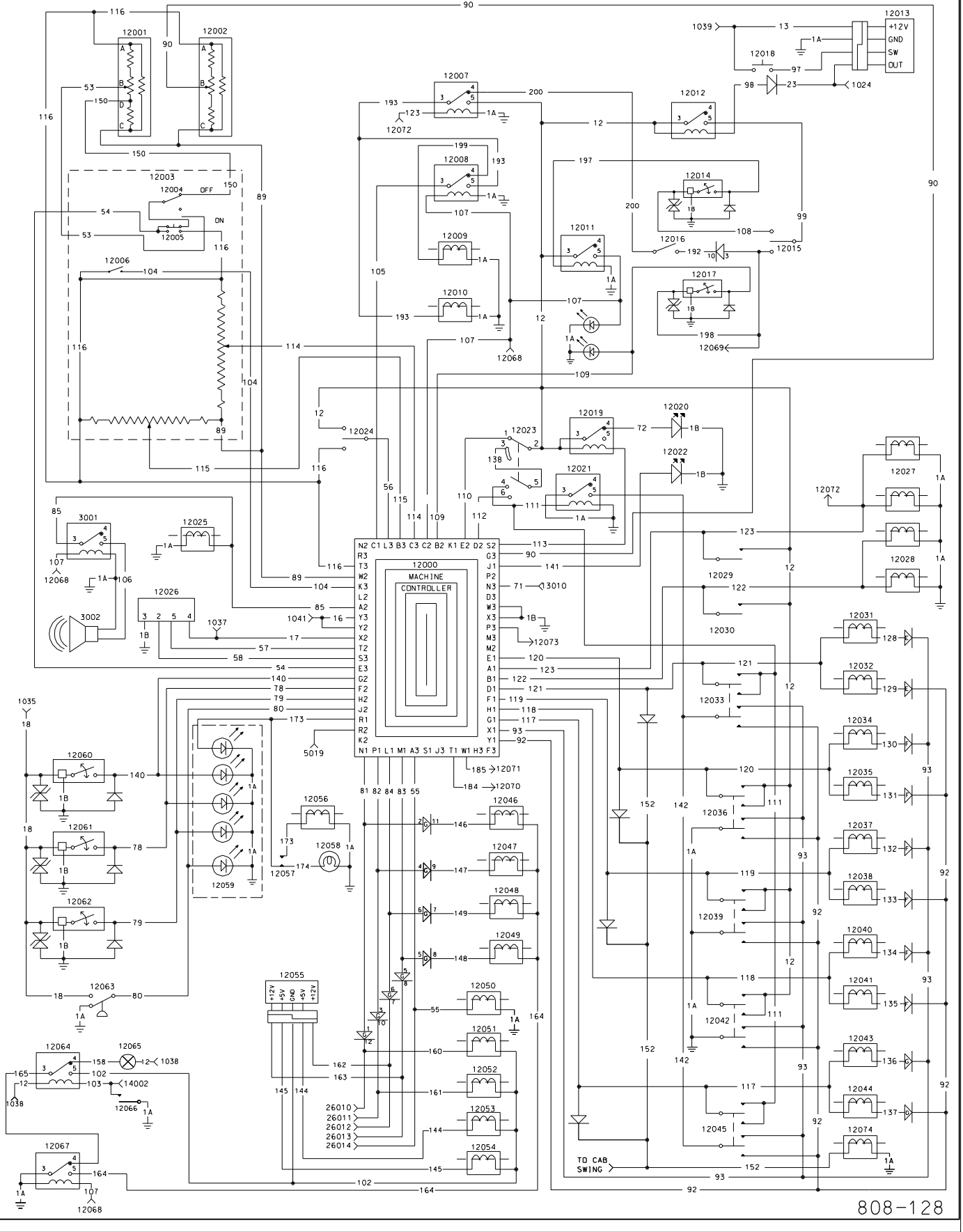

ELECTRICAL SCHEMATIC

JT4020 ALL TERRAIN

1000 -- POWER

REF.	DESCRIPTION	WIRE DESCRIPTION	NOTES
1001	BATTERY	1. BLK, 2. RED	
1002	BATTERY DISCONNECT	1. BLK	
1003	MAIN FUSE	2. RED, 3. RED	
1004	START FUSE	2. RED, 4. RED/BLK	
1005	WORKLIGHT FUSE	2. RED, 6. BLU	
1006	IGN SWITCH	3. RED, 9. ORG, 10. ORG/BLU, 11. WHT/BLK	
1007	START RELAY	4. RED/BLK, 24. PUR, 11. WHT/BLK 139. WHT/ORG	
1008	ACCESSORY SOCKET FUSE	3. RED, 14. RED/WHT	
1009	ACCESSORY SOCKET	1A. BLK/RED, 14. RED/WHT	
1010	TRACCOM FUSE	3. RED, 151. BLU/RED	
1011	E.S.I.D. FUSE	9. ORG, 20. RED/YEL	
1012	GAUGES FUSE	9. ORG, 19. ORG/BRN	
1013	VARIABLE THROTTLE FUSE	9. ORG, 21. RED/ORG	
1014	SENSORS FUSE	9. ORG, 18. RED/BLK	
1015	ECM CUTOFF FUSE	9. ORG, 29. RED/BRN	
1016	ECM CONTROL FUSE	9. ORG, 17. RED/BLU	
1017	ACC FUSE	9. ORG, 12. ORG	
1018	IGN FUSE	10. ORG/BLU, 13. ORG/GRN	
1019	WARNING LIGHTS	10. ORG/BLU, 22. GRA/ORG	
1020	TO START	11. WHT/BLK	
1021	TO BATTERY FUSED	3. RED	
1022	TO BATTERY	2. RED	
1023	TO HOURMETER	45. ORG/BLK	
1024	TO SEAT SWITCH DELAY TIMER	23. WHT/RED	
1025	TO WORK LIGHTS	6. BLU	
1026	COLD START SWITCH	24. PUR, 25. BRN/ORG	
1027	TO COLD START SOLENOID	25. BRN/ORG, 26. BLK	
1028	COLD START TEMP. SWITCH	1. BLK, 26. BLK	
1029	STARTER SOLENOID	24. PUR, CHASSIS GROUND	
1030	STARTER MOTOR	2. RED, CHASSIS GROUND	
1031	TO TRACCOM	151. BLU/RED	
1032	TO ELECTRICAL STRIKE & REMOTE DISPLAY	20. RED/YEL	
1033	TO GAUGES	19. ORG/BRN	
1034	TO VARIABLE THROTTLE	21. RED/ORG	
1035	TO SENSORS	18. RED/BLK	
1036	TO ECM CUTOFF RELAY	29. RED/BRN	
1037	ECM CONTROL	17. RED/BLU	
1038	TO ACC	12. ORG	
1039	TO IGN	13. ORG/GRN	
1040	TO WARNING LIGHTS	22. GRA/ORG	
1041	TO ECM	16. RED/GRN	
1042	ECM CUTOFF RELAY	1A. BLK/RED, 16. RED/GRN, 29. RED/BRN 34. GRN/RED, 44. YEL/RED	
1043	FUEL SOLENOID	45. ORG/BLK, CHASSIS GROUND	
1044	TO ENGINE STOP SWITCH	44. YEL/RED	
1045	ENGINE STOP SWITCH	13. ORG/GRN, 44. YEL/RED	
1046	ENGINE STOP RELAY	1A. BLK/RED, 13. ORG/GRN, 43. BLU 44. YEL/RED, 166. WHT	
1047	START BYPASS DELAY TIMER	1A. BLK/RED, 13. ORG/GRN, 11. WHT/BLK 40. GRN	
1048	E.O.P. FUEL SHUTDOWN RELAY	36. WHT/BLU, 40. GRN, 43. BLU, 45. ORG/BLK	
1049	ENGINE OIL PRESSURE SWITCH	36. WHT/BLU, CHASSIS GROUND	
1050	LATCH RELEASE RELAY	1A. BLK/RED, 11. WHT/BLK, 44. YEL/RED 166. WHT	

ELECTRICAL SCHEMATIC

JT4020 ALL TERRAIN

2000 -- ALTERNATOR

REF.	DESCRIPTION	WIRE DESCRIPTION	NOTES
2001	ALTERNATOR	1. BLK, 2. RED, 27. ORG/BLU	
2002	DIODE PACK	13. ORG/GRN, 27. ORG/BLU	

3000 -- BACKUP ALARM

REF.	DESCRIPTION	WIRE DESCRIPTION	NOTES
3001	BACKUP ALARM RELAY	1A. BLK/RED, 85. PUR/GRN, 106. BLU/ORG, 107. YEL/GRN	
3002	BACKUP ALARM	1A. BLK/RED, 106. BLU/ORG	

4000 -- HORN

REF.	DESCRIPTION	WIRE DESCRIPTION	NOTES
4001	HORN BUTTON	12. ORG, 30. TAN/BLU	
4002	HORN	1A. BLK/RED, 30. TAN/BLU	

5000 -- GAUGES

REF.	DESCRIPTION	WIRE DESCRIPTION	NOTES
5001	HOURMETER	1B. BLK/BLU, 45. ORG/BLK	
5002	INNER ROTATION HOURMETER	1B. BLK/BLU, 183. YEL/WHT	
5003	VOLTMETER	1B. BLK/BLU, 19. ORG/BRN, 59. TAN/RED	
5004	FUEL GAUGE	1B. BLK/BLU, 19. ORG/BRN, 31. BRN, 59. TAN/RED	
5005	FUEL SENDER	31. BRN	
5006	OIL PRESSURE GAUGE	1B. BLK/BLU, 19. ORG/BRN, 32. BLU, 59. TAN/RED	
5007	OIL PRESSURE SENDER	32. BLU	
5008	WATER TEMP. GAUGE	1B. BLK/BLU, 19. ORG/BRN, 33. GRN 35. BLU/RED, 59. TAN/RED	
5009	WATER TEMP. SENDER	33. GRN	
5010	ENGINE TACH.	1B. BLK/BLU, 19. ORG/BRN, 28. YEL 59. TAN/RED	
5011	ENGINE SPEED SENSOR	28. YEL, 1A. BLK/RED	
5012	FLUID FLOW DISPLAY	1B. BLK/BLU, 12. ORG, 75. WHT/BRN	
5013	FLUID FLOW SPEED SENSOR	1B. BLK/BLU, 18. RED/BLK, 75. WHT/BRN	
5014	OUTER ROTATION TACH	1B. BLK/BLU, 19. ORG/BRN, 190. GRN/RED	
5015	OUTER ROTATION SPEED SENSOR	1A. BLK/RED, 190. GRN/RED	
5016	INNER ROTATION TACH	1B. BLK/BLU, 19. ORG/BRN, ??? PUR/BLK	
5017	INNER ROTATION SPEED SENSOR	1A. BLK/RED, ??? PUR/BLK	
5018	TO TRACCDM	28. YEL	
5019	TO ECM	??? PUR/BLK	
5020	TO WARNING ALARM	35. BLU/RED	

7000 -- THROTTLE CONTROL

REF.	DESCRIPTION	WIRE DESCRIPTION	NOTES
7001	LINEAR ACTUATOR	1A. BLK/RED, 48. PUR/ORG, 50. BLU/ORG	
7002	THROTTLE SWITCH	1A. BLK/RED, 21. RED/ORG, 48. PUR/ORG 50. BLU/ORG	

8000 -- WARNING LIGHTS & ALARM

REF.	DESCRIPTION	WIRE DESCRIPTION	NOTES
8001	HYDRAULIC FILTER	22. GRA/ORG, 38. GRA/YEL	
8002	HYDRAULIC HIGH TEMP. LIGHT	22. GRA/ORG, 39. GRA/BLK	
8003	WARNING LIGHT ALARM	22. GRA/ORG, 35. BLU/RED	
8004	HYDRAULIC FILTER SWITCH	38. GRA/YEL, CHASSIS GROUND	
8005	HYDRAULIC HIGH TEMP. SWITCH	39. GRA/BLK, CHASSIS GROUND	
8006	LIGHT TEST RELAY	1A. BLK/RED, 11. WHT/BLK, 42. BLK/ORG	

ELECTRICAL SCHEMATIC

JT4020 ALL TERRAIN

11000 -- WORKLIGHTS

REF.	DESCRIPTION	WIRE DESCRIPTION	NOTES
11001	WORKLIGHT RELAY	1A. BLK/RED, 6. BLU, 59. TAN/RED 60. YEL	
11002	WORKLIGHTS	1. BLK, 60. YEL	
11003	WORKLIGHT SWITCH	12. ORG, 59. TAN/RED	
11004	TO GAUGE LIGHTS	59. TAN/RED	
11005	TO AUX LIGHTS	60. YEL	

12000 -- MACHINE CONTROL

REF.	DESCRIPTION	WIRE DESCRIPTION	NOTES
12001	FLUID FLOW POT	53. BLK/YEL, 89. YEL/BLK, 116. BLU/GRN 150. YEL	
12002	VARIABLE ROTATION POT	89. YEL/BLK, 90. WHT/GRN, 116. BLU/GRN	
12003	JOYSTICK	53. BLK/YEL, 54. BLK/WHT, 89. YEL/BLK, 114. GRA/GRN, 115. TAN/GRN, 116. BLU/GRN 150. YEL	
12004	FLUID SWITCH	53. BLK/YEL, 54. BLK/WHT, 150. YEL	
12005	QUICK FILL SWITCH	54. BLK/WHT, 116. BLU/GRN	
12006	CARRIAGE HIGH SPEED SWITCH	104. PUR/RED, 116. BLU/GRN	
12007	SPINDLE BRAKE RELAY	1A. BLK/RED, 12. ORG, 123. BRN, 193. PUR/RED, 200. GRA/BLU	
12008	HIGH SPEED RELAY	1A. BLK/RED, 105. PUR/ORG, 107. YEL/GRN 193. PUR/RED, 199. GRN/BLU	
12009	CARRIAGE HIGH SPEED SOLENOID	1A. BLK/RED, 199. GRN/BLU	
12010	GROUND DRIVE HIGH SPEED / SPINDLE BRAKE SOLENOID	1A. BLK/RED, 193. PUR/RED	
12011	DRIVE SWITCH RELAY	1A. BLK/RED, 12. ORG, 107. YEL/GRN 197. PUR/WHT	
12012	DRILL/DRIVE ENABLE RELAY	12. ORG, 98. RED/WHT, 99. ORG/WHT	
12013	TWO SECOND SEAT SWITCH DELAY TIMER	1A. BLK/RED, 13. ORG/GRN, 23. WHT/RED 97. BLU/YEL	
12014	DRIVE POSITION SWITCH	108. GRA, 197. PUR/WHT	
12015	DRILL/DRIVE SWITCH	99. ORG/WHT, 108. GRA, 198. YEL/WHT	
12016	SPINDLE BRAKE SWITCH	192. PUR/WHT, 200. GRA/BLU	
12017	DRILL POSITION SWITCH	109. YEL/PUR, 198. YEL/WHT	
12018	SEAT SWITCH	13. ORG/GRN, 97. BLU/YEL	
12019	DIAGNOSTIC LIGHT RELAY	12. ORG, 72. PNK/BLK, 113. TAN/BLK	
12020	DIAGNOSTIC LIGHT	1B. BLK/BLU, 72. PNK/BLK	
12021	MANUAL RELAY	1A. BLK/RED, 111. WHT/ORG, 142. WHT/RED	
12022	CONTROL CYCLE LIGHT	1B. BLK/BLU, 141. PNK	
12023	ADD/MANUAL/REMOVE SWITCH	12. ORG, 110. BRN/ORG, 111. WHT/ORG 112. BRN/YEL, 138. WHT	
12024	SET/RESUME SWITCH	12. ORG, 56. TAN/WHT, 116. BLU/GRN	
12025	VARIABLE ROTATION SOLENOID	1A. BLK/RED, 85. PUR/GRN	
12026	DIAGNOSTIC CONNECTION	1B. BLK/BLU, 17. RED/BLU, 57. PNK/BLU, 58. PNK/WHT	
12027	FRONT WRENCH CLAMP SOLENOIDS	1A. BLK/RED, 123. BRN	
12028	REAR WRENCH CLAMP SOLENOIDS	1A. BLK/RED, 122. YEL	
12029	FRONT WRENCH SWITCH	12. ORG, 123. BRN	
12030	REAR WRENCH SWITCH	12. ORG, 122. YEL	
12031	PIPE LIFT UP SOLENOID	121. BLU, 128. BLU/GRN	
12032	PIPE LIFT DOWN SOLENOID	121. BLU, 129. BLU/YEL	
12033	PIPE LIFT SWITCH	92. GRN/BLK, 93. BLU/BLK, 111. WHT/ORG 121. BLU, 142. WHT/RED	
12034	PIPE GRIPPER OPEN SOLENOID	120. GRN, 103. GRN/BLU	
12035	PIPE GRIPPER CLOSE SOLENOID	120. GRN, 131. GRN/ORG	

ELECTRICAL SCHEMATIC

JT4020 ALL TERRAIN

27000 -- CAB SWING

REF.	DESCRIPTION	WIRE DESCRIPTION	NOTES
27001	IN/OUT SWITCH	12. ORG, 61. YEL/BLK, 62. PUR/BLK	
27002	IN SOLENOID	1A. BLK/RED, 61. YEL/BLK	
27003	OUT SOLENOID	1A. BLK/RED, 62. PUR/BLK	
27004	CAB SWING TO DUMP VALVE	152. GRA/RED	

28000 -- GREASER HEATER

REF.	DESCRIPTION	WIRE DESCRIPTION	NOTES
28001	GREASER HEATER ELEMENT	1A. BLK/RED, 12. ORG	

29000 -- TRACCOM OPTION

REF.	DESCRIPTION	WIRE DESCRIPTION	NOTES
29001	TRACCOM	1B. BLK/BLU, 28. YEL, 151. BLU/RED	

30000 -- FAN CLUTCH

REF.	DESCRIPTION	WIRE DESCRIPTION	NOTES
30001	FAN CLUTCH	12. ORG, 37. WHT/GRN	
30002	WATER TEMP SWITCH	1A. BLK/RED, 12. ORG, 37. WHT/GRN	
30003	MANUAL SWITCH	1A. BLK/RED, 37. WHT/GRN	

ELECTRICAL SCHEMATIC

JT4020 ALL TERRAIN

REF.	DESCRIPTION	WIRE DESCRIPTION	NOTES
12036	PIPE GRIP SWITCH	1A. BLK/RED, 12. ORG, 92. GRN/BLK 93. BLU/BLK, 120. GRN	
12037	SAVER SUB LUBRICATOR	119. GRA, 132. GRA/GRN	
12038	PIPE END LUBRICATOR	119. GRA, GRA/YEL	
12039	LUBRICATOR SWITCH	1A. BLK/RED, 12. ORG, 92. GRN/BLK 93. BLU/BLK, 119. GRA	
12040	REAR WRENCH CW ROTATE SOLENOID	118. PUR, 134. PUR/GRN	
12041	REAR WRENCH CCW ROTATE SOLENOID	118. PUR, 135. PUR/YEL	
12042	REAR WRENCH SWITCH	1A. BLK/RED, 12. ORG, 92. GRN/BLK 93. BLU/BLK, 118. PUR	
12043	SHUTTLE EXTEND SOLENOID	117. TAN, 136. TAN/GRN	
12044	SHUTTLE RETRACT SOLENOID	117. TAN, 137. TAN/WHT 92. GRN/BLK, 93. BLU/BLK, 111. WHT/DRG	
12045	SHUTTLE SWITCH	117. TAN, 142. WHT/RED	
12046	RIGHT TRACK FORWARD SOLENOID	146. GRN/PUR, 164. WHT/YEL	
12047	RIGHT TRACK REVERSE SOLENOID	147. GRN/RED, 164. WHT/YEL	
12048	LEFT TRACK FORWARD SOLENOID	149. GRN/ORG, 164. WHT/YEL	
12049	LEFT TRACK REVERSE SOLENOID	148. GRN/YEL, 164. WHT/YEL	
12050	DRILL FLUID SOLENOID	1A. BLK/RED, 55. WHT/BLK	
12051	THRUST FORWARD SOLENOID	102. WHT/GRN, 160. TAN/ORG	
12052	THRUST REVERSE SOLENOID	102. WHT/YEL, 161. TAN/YEL	
12053	ROTATION CW SOLENOID	102. WHT/GRN, 144. PUR/DRG	
12054	ROTATION CCW SOLENOID	102. WHT/GRN, 145. PUR/YEL	
12055	ROTATION VOLTAGE TRANSLATOR	102. WHT/GRN, 144. PUR/ORG, 145. PUR/YEL 162. ORG/GRA, 163. YEL/GRA	
12056	CHECK VALVE SOLENOID	1A. BLK/RED, 173. BRN/WHT	
12057	CHECK VALVE SWITCH	173. BRN/WHT, 174. GRN/RED	
12058	BYPASS LIGHT	1A. BLK/RED, 174. GRN/RED	
12059	STATUS LIGHTS	1A. BLK/RED, 78. GRA/WHT, 79. WHT/RED 80. WHT, 140. TAN/RED, 173. BRN/WHT	
12060	FRONT HOME SWITCH	1B. BLK/BLU, 18. RED/BLK, 140. TAN/RED	
12061	REAR HOME SWITCH	1B. BLK/BLU, 18. RED/BLK, 78. GRA/WHT	
12062	SHUTTLE HOME SWITCH	1B. BLK/BLU, 18. RED/BLK, 79. WHT/RED	
12063	FRONT WRENCH SWITCH	1B. BLK/BLU, 18. RED/BLK, 80. WHT	
12064	TRACKER CONTROL RELAY	12. ORG, 102. WHT/GRN, 103. TAN/RED, 158. GRA/PUR, 165. TAN/PUR	
12065	TRACKER CONTROL STROBE	12. ORG, 158. GRA/PUR	
12066	TRACKER CONTROL KEY SWITCH	1A. BLK/RED, 103. TAN/RED	
12067	DRIVE SOLENOID RELAY	1A. BLK/RED, 107. YEL/GRN, 164. WHT/YEL 165. TAN/PUR	
12068	DRIVE RELAY	107. YEL/GRN	
12069	TO DRILL POSITION SWITCH	198. YEL/WHT	
12070	TO INNER ROTATION CW SOLENOID	184. BRN/BLU	
12071	TO INNER ROTATION CCW SOLENOID	185. BRN/RED	
12072	TO SPINDLE BRAKE RELAY	123. BRN	
12073	TO INNER ROTATION POT	182. TAN/BLU	
12074	PIPELOADER DUMP VALVE	1A. BLK/RED 152. GRA/RED	

13000 -- ELECTRICAL STRIKE

REF.	DESCRIPTION	WIRE DESCRIPTION	NOTES
13001	ESID SHUTDOWN RELAY	3. RED, 67. ORG/RED, 68. TAN/BLK	
13002	ESID DELAY TIMER	1A. BLK/RED, 67. ORG/RED, 68. TAN/BLK, 71. WHT/YEL	
13003	ESID STROBE	1A. BLK/RED, 69. WHT/YEL	
13004	STROBE RELAY	1A. BLK/RED, 67. ORG/RED, 69. WHT/YEL 71. WHT/PUR	

ELECTRICAL SCHEMATIC

JT4020 ALL TERRAIN

REF.	DESCRIPTION	WIRE DESCRIPTION	NOTES
13005	CURRENT COIL		
13006	ESID ALARM	1A. BLK/RED, 70. BRN	
13007	ESID MODULE	1A. BLK/RED, 67. ORG/RED, 70. BRN 71. WHT/PUR	
13008	VOLTAGE LIMITER		
13009	VOLTAGE STAKE		
13010	STRIKE TO ECM	71. WHT/PUR	

14000 -- REMOTE DISPLAY

REF.	DESCRIPTION	WIRE DESCRIPTION	NOTES
14001	REMOTE DISPLAY	1B. BLK/BLU, 20. ORG/RED, 103. TAN/RED 153. WHT, 154. YEL, 155. BLK	
14002	TO TRACKER CONTROL	103. TAN/RED	

25000 -- AT OPTION

REF.	DESCRIPTION	WIRE DESCRIPTION	NOTES
25001	JT/AT SWITCH	12. ORG, 176. YEL/RED, 177. YEL/BLU, 178. PUR, 181. BLU/PUR	
25002	INNER ROTATION SWITCH	177. YEL/BLU, 178. PUR, 179. TAN/YEL 181. BLU/PUR, 196. BRN/BLK	
25003	INNER ROTATION POT.	1A. BLK/RED, 181. BLU/PUR, 182. TAN/BLU 196. BRN/BLK	
25004	INNER ROTATION CW SOLENOID	102. WHT/GRN, 184. BRN/BLU	
25005	INNER ROTATION CCW SOLENOID	102. WHT/GRN, 185. BRN/RED	
25006	INNER ROTATION MANUAL SWITCH	180. TAN/ORG, 184. BRN/BLU, 185. BRN/RED	
25007	FRONT WRENCH RELAY	1A. BLK/RED, 46. BLK/ORG, 123. BRN, 196. BRN/BLK	
25008	INNER ROTATION HOURMETER RELAY	1A. BLK/RED, 45. ORG/BLK, 46. BLK/ORG, 183. YEL/WHT	
25009	THRUST LIMITER SOLENOID	1A. BLK/RED, 176. YEL/RED	
25010	INNER ROTATION SOLENOID GROUND	102. WHT/GRN	
25011	TO INNER ROTATION HOURMETER	183. YEL/WHT	
25012	ROTATION GAUGE SELECTOR SOLENOID	1A. BLK/RED, 46. BLK/ORG	

26000 -- DRILL/DRIVE AUXILLIARY SWITCHES

REF.	DESCRIPTION	WIRE DESCRIPTION	NOTES
26001	LEFT TRACK SWITCH	148. GRN/YEL, 149. GRN/ORG, 167. BLU/WHT	
26002	RIGHT TRACK SWITCH	146. BRN/PUR, 147. GRN/RED, 168. GRN/WHT	
26003	THRUST SWITCH	94. WHT/ORG, 160. TAN/ORG, 161. TAN/YEL	
26004	ROTATION SWITCH	95. WHT/RED, 162. ORG/GRA, 163. YEL/GRA	
26005	DRILL FLUID SWITCH	55. WHT/BLK, 96. WHT/BLU	
26006	TO LEFT TRACK FWD	149. GRN/ORG	
26007	TO LEFT TRACK REV	148. GRN/YEL	
26008	TO RIGHT TRACK FWD	146. GRN/PUR	
26009	TO RIGHT TRACK REV	147. GRN/RED	
26010	TO THRUST FWD	160. TAN/ORG	
26011	TO THRUST REV	161. TAN/YEL	
26012	TO ROTATION CW	162. ORG/GRA	
26013	TO ROTATION CCW	163. YEL/GRA	
26014	TO DRILL FLUID	55. WHT/BLK	

ELECTRICAL DIAGRAM ENGINE HARNESS

REF NO.	PART NUMBER	QTY	DESCRIPTION	REMARKS
1.	217-254	1	ENGINE HARNESS	
2.	211-017	1	12V-5V VOLTAGE CONVERTOR	
3.	N/A	1	RESTRICTION SWITCH	
4.	217-770	2	SOLENOID COIL	
5.	214-256	1	DIODE CONNECTOR	
6.	217-550	-	WATER TEMPERATURE SENDER	
7.	215-183	-	SENDER, OIL PRESSURE HD	
8.	217-736	-	OIL PRESSURE SWITCH	
9.	215-231	1	LINEAR ACTUATOR	INCL CABLE & ROLL PIN & PIGTAIL
	214-299	-	ACTUATOR PIGTAIL	
	196-331	-	CABLE (LINEAR ACTUATOR)	
	501-358	-	ROLL PIN (3/32" x f")	
10.	217-041	-	STROBE LIGHT (12V DC)	
11.	306-602	-	BACKUP ALARM	
12.	211-022	1	STARTER	
13.	217-451	1	ALTERNATOR 95 AMP (REMAN)	
14.	214-491	1	COIL, 12V	AT ONLY
	214-209	1	2-WAY MALE CAP	JT ONLY
15.	214-895	-	TEMPERATURE SWITCH	
16.	194-298	-	FAN DRIVE	
17.	213-080	-	WHEEL SPEED SENSOR	

FOOTNOTES

NOTE:

F

808-013

ELECTRICAL DIAGRAM ENGINE HARNESS

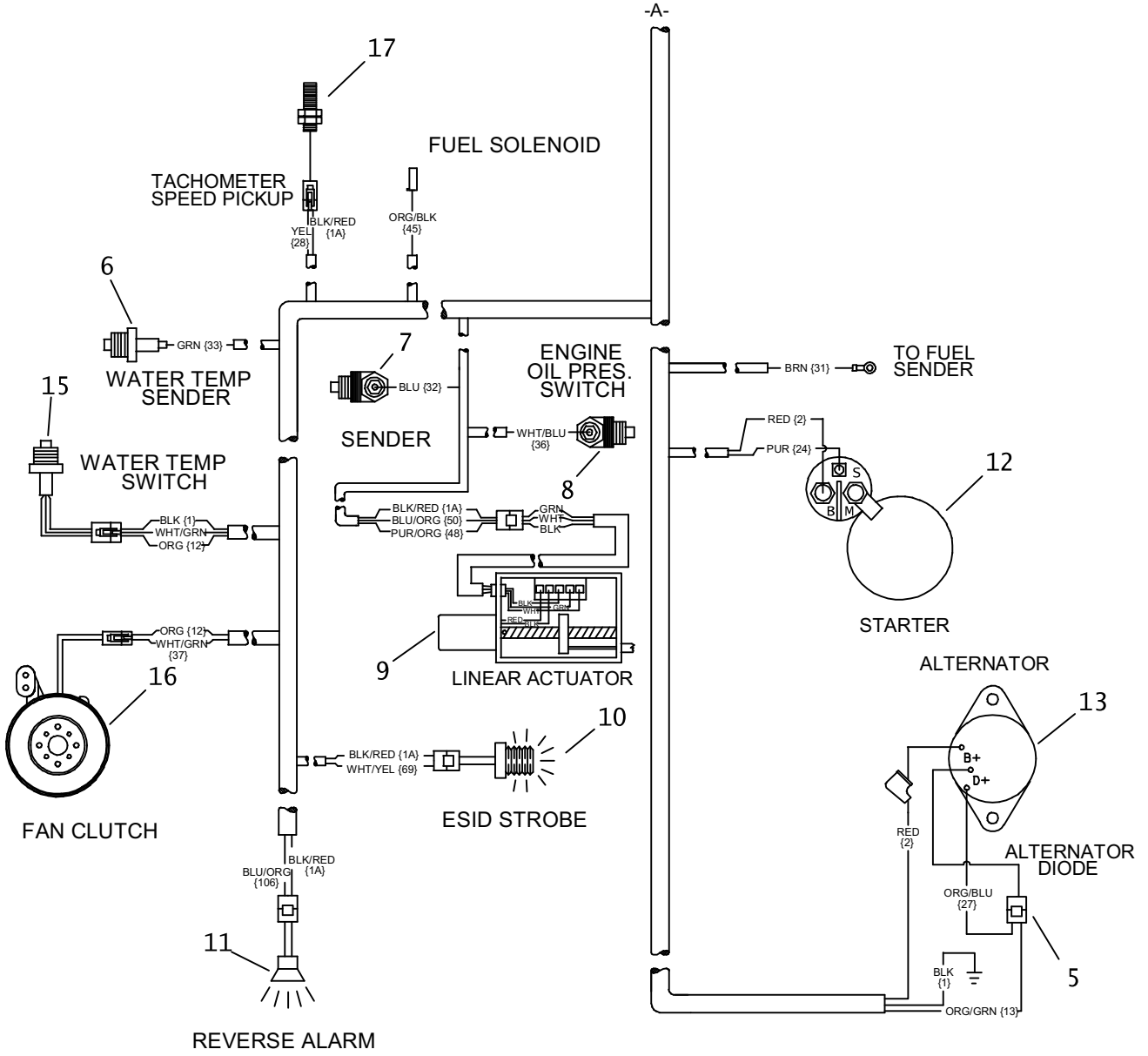

ELECTRICAL DIAGRAM AT/JT RELAY PANEL

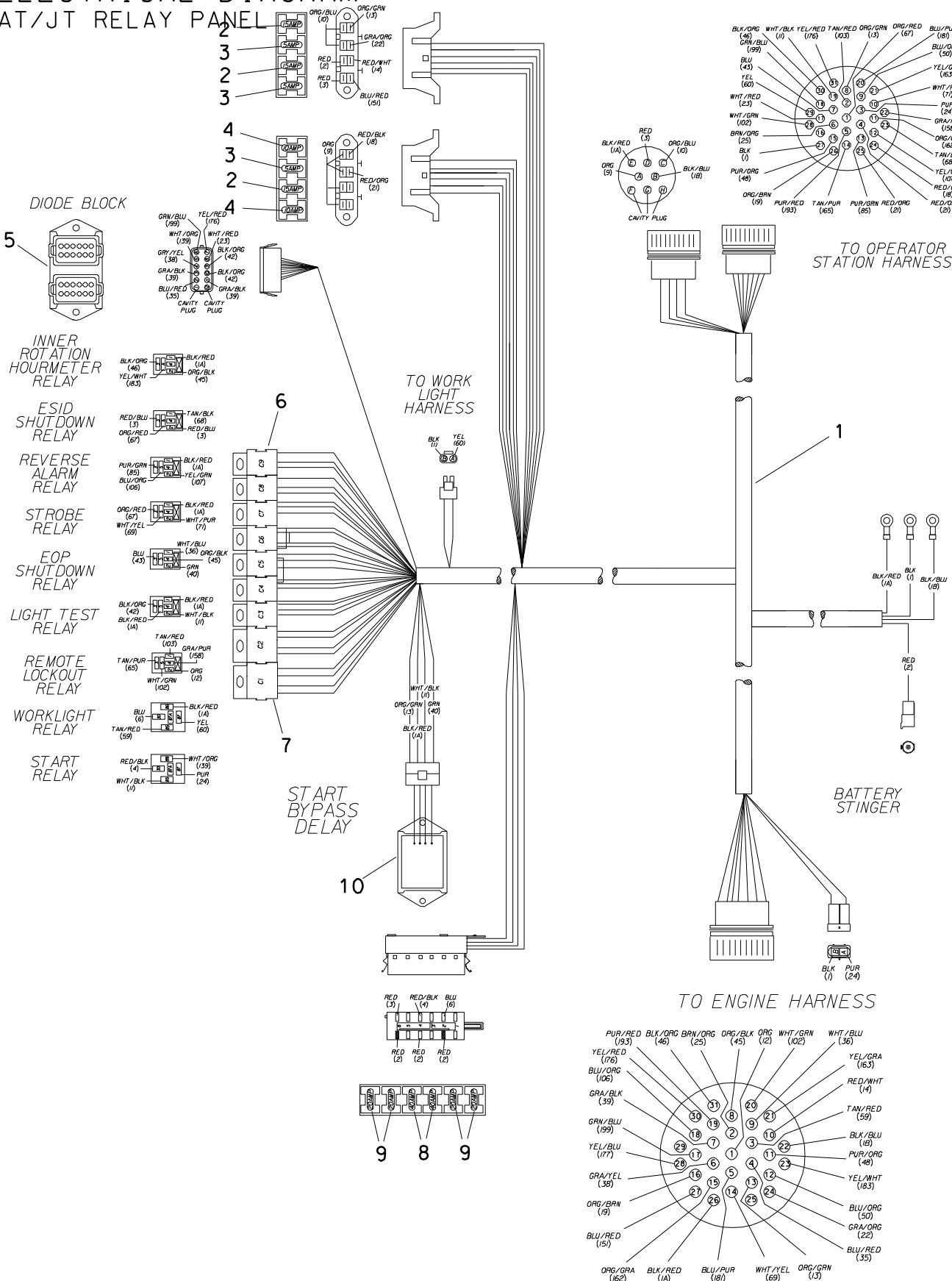

C

ELECTRICAL DIAGRAM

AT/JT RELAY PANEL

REF NO.	PART NUMBER	QTY	DESCRIPTION	REMARKS
1.	217-252	1	AT/JT RELAY PANEL	
2.	217-811	3	FUSE (ATC, 15 AMP)	
3.	217-809	3	FUSE (ATC, 5 AMP)	
4.	217-810	2	FUSE (ATC, 10 AMP)	
5.	211-026	1	DIODE PACK (DEUTSCH)	
6.	217-710	7	MICRO RELAY (SPDT)	
7.	217-826	2	MINI RELAY (SPDT)	
8.	217-791	2	FUSE (MAXI, 40 AMP)	
9.	217-805	4	FUSE (MAXI, 20AMP)	
10.	217-937	1	START BYPASS DELAY TIMER	

FOOTNOTES

ELECTRICAL DIAGRAM AT/JT GAUGE HARNESS

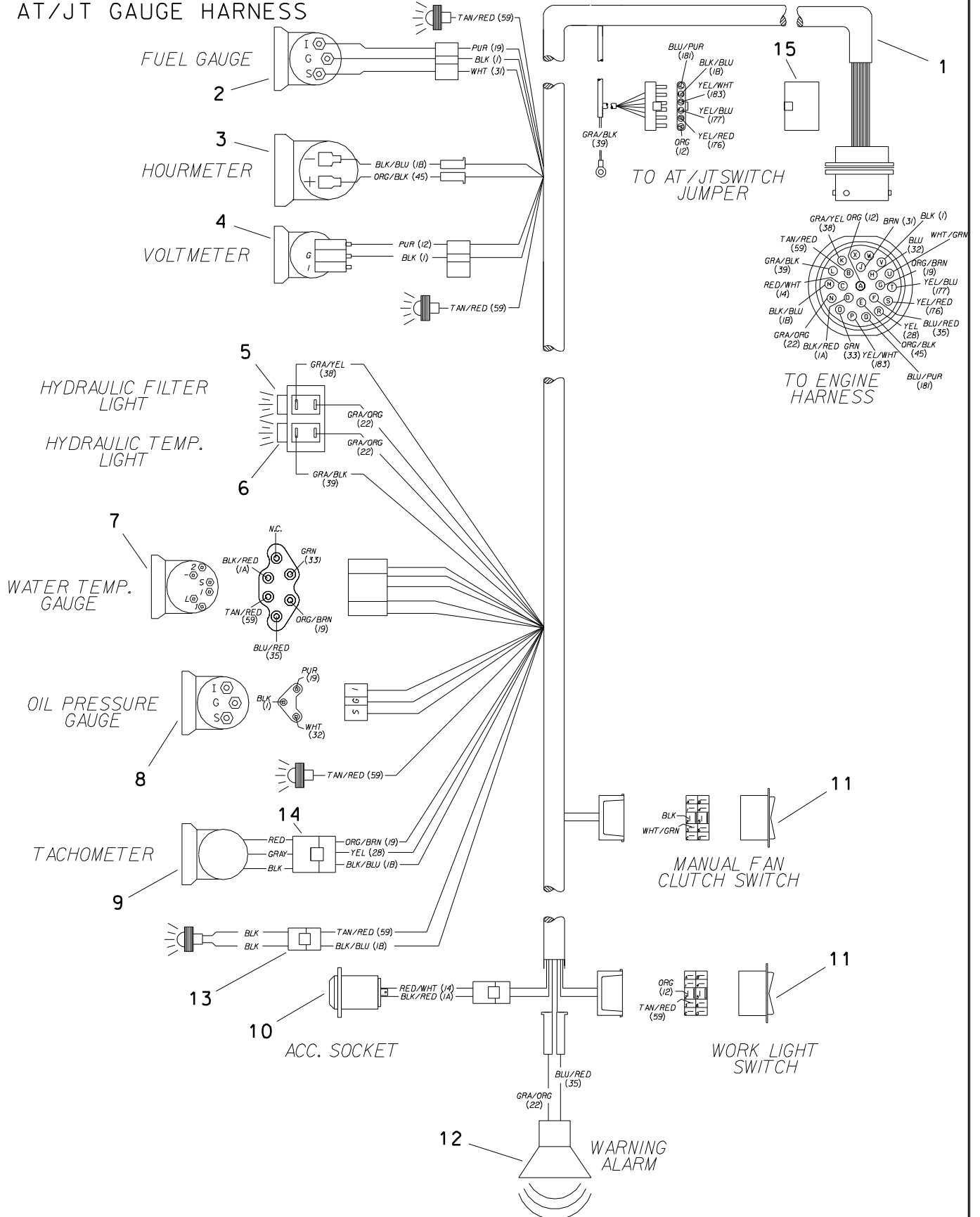

ELECTRICAL DIAGRAM

AT/JT GAUGE HARNESS

REF NO.	PART NUMBER	QTY	DESCRIPTION	REMARKS
1.	217-256	1	AT/JT GAUGE HARNESS	
2.	215-133	1	FUEL GAUGE	
3.	215-128	1	HOUR METER	
4.	215-129	1	VOLT METER	
5.	217-036	1	INSERT (YEL) HYD OIL PSI	
6.	217-027	1	INSERT (RED) HYD OIL HI TEMP	
7.	258-037	1	WATER TEMPERATURE GAUGE	
8.	215-131	1	OIL PRESSURE GAUGE	
9.	211-070	1	TACHOMETER (3000 RPM)	
10.	214-301	1	ACCESSORY SOCKET	
11.	217-907	2	ROCKER SWITCH (DPDT) ON-ON	
12.	306-603	1	AUDIO ALARM	
13.	214-047	1	2-WAY WEATHER PACK FEMALE CONN.	
	214-104	2	PACKARD MALE TERMINAL	
	157-645	2	WEATHER-PAC SEAL (2.80MM)	
14.	215-224	1	3-WAY WP MALE CONNECTOR	
	214-104	3	PACKARD MALE TERMINAL	
	157-645	3	WEATHER-PAC SEAL (2.80MM)	
15.	215-228	1	6-WAY MALE W.P. CONNECTOR	JT ONLY
	211-060	6	WP CAVITY PLUG	JT ONLY

FOOTNOTES

ELECTRICAL DIAGRAM

WATER TEMP GAUGE HARNESS

ENDS WITH S/N -----

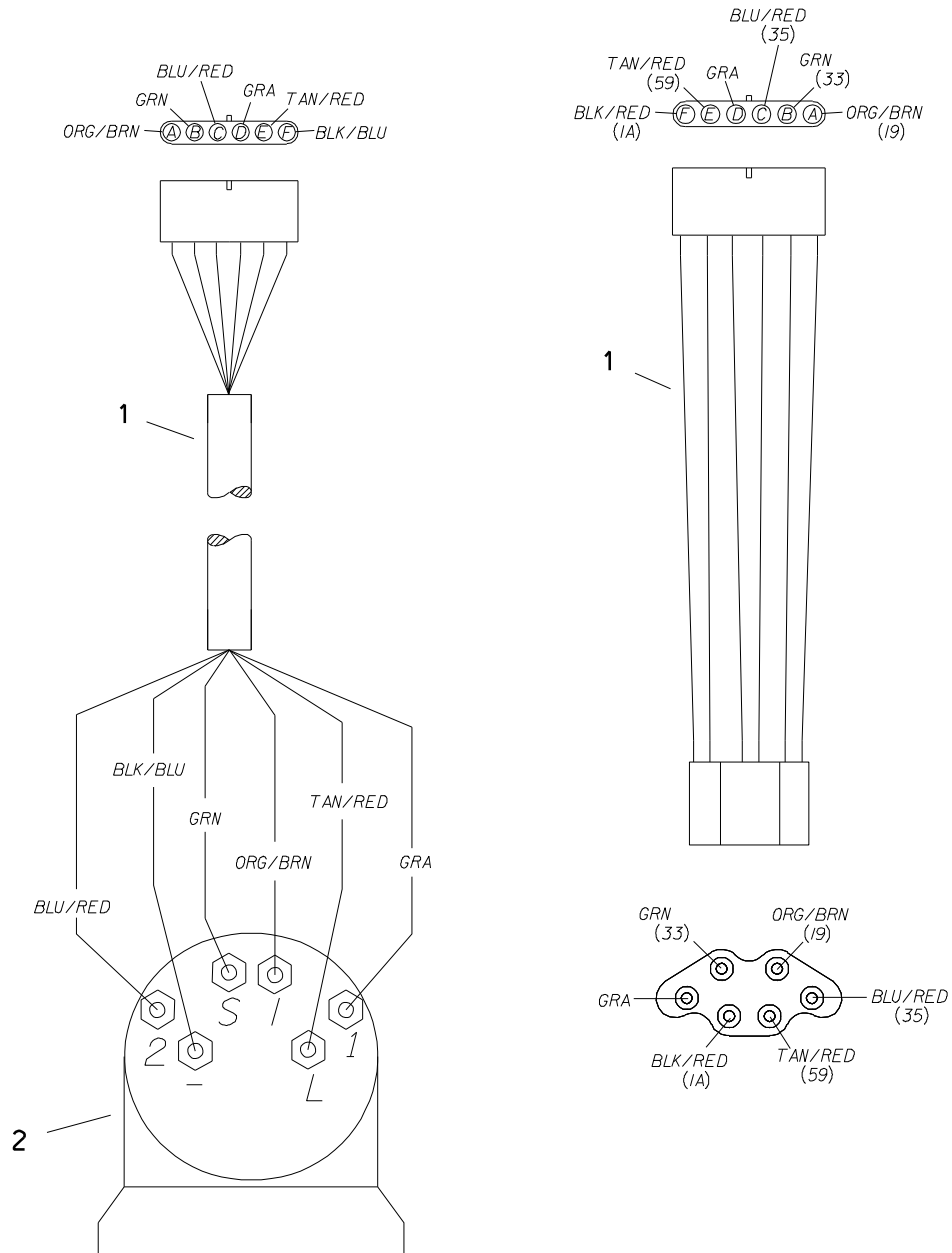

ELECTRICAL DIAGRAM
 WATER TEMP GAUGE HARNESS
 ENDS WITH S/N -----

REF NO.	PART NUMBER	QTY	DESCRIPTION	REMARKS
1.	214-811	1	TEMPERATURE GAUGE HARNESS	OLD STYLE
	214-936	1	WATER TEMP GAUGE HARNESS	NEW STYLE, SEE FOOTNOTE 1
2.	258-037	-	WATER TEMPERATURE GAUGE	

FOOTNOTES

- 1. USE AS A REPLACEMENT COMPONENT FOR 214-811

ELECTRICAL DIAGRAM
 AT/JT SWITCH JUMPER
 JT4020 ALL TERRAIN ONLY

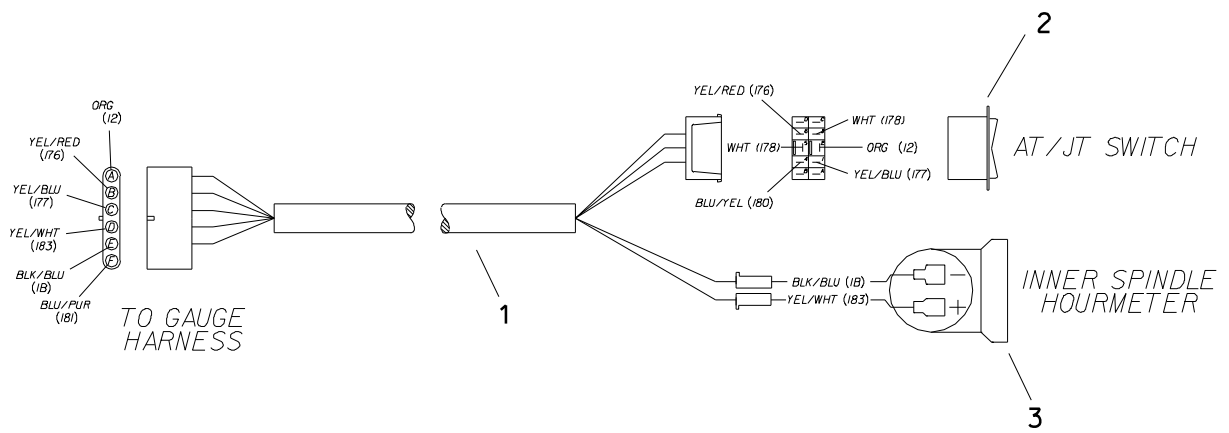

ELECTRICAL DIAGRAM

AT/JT SWITCH JUMPER

JT4020 ALL TERRAIN ONLY

REF NO.	PART NUMBER	QTY	DESCRIPTION	REMARKS
1.	214-891	1	AT/JT SWITCH JUMPER	
2.	217-912	1	ROCKER SWITCH (DPDT) ON-ON-ON	
3.	215-128	-	HOURLY METER	

FOOTNOTES

ELECTRICAL DIAGRAM OPERATOR STATION HARNESS

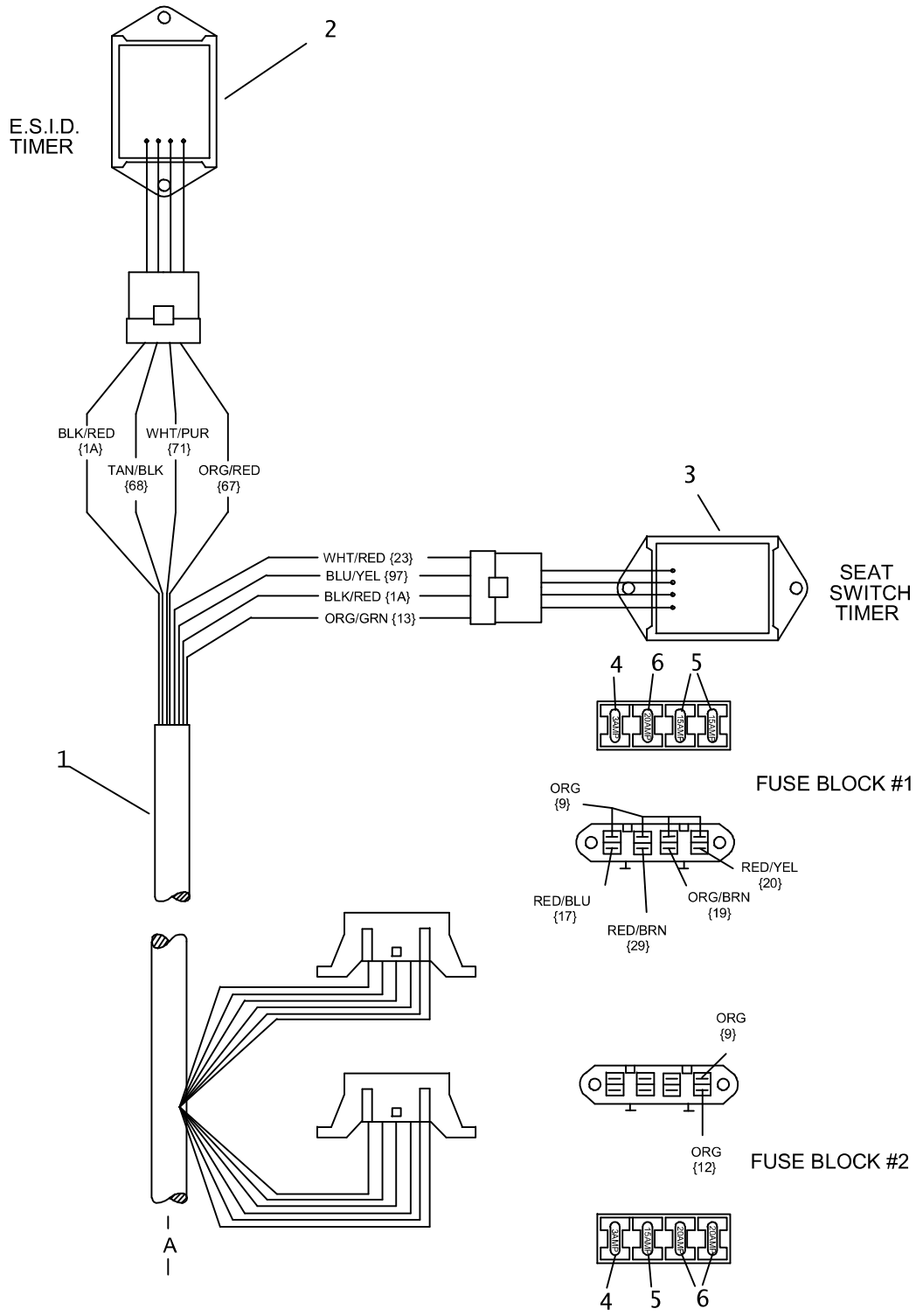

ELECTRICAL DIAGRAM OPERATOR STATION HARNESS

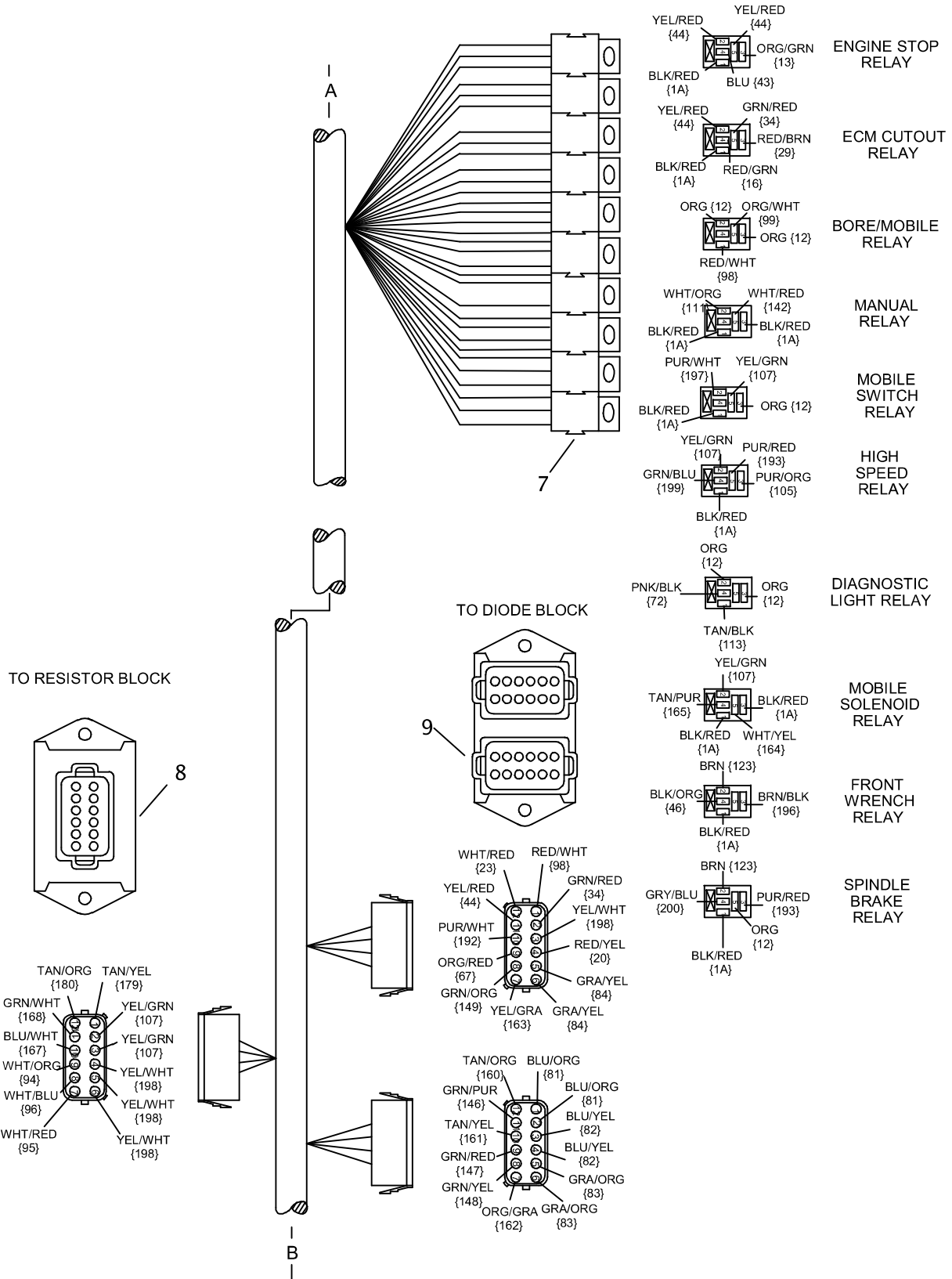

ELECTRICAL DIAGRAM OPERATOR STATION HARNESS

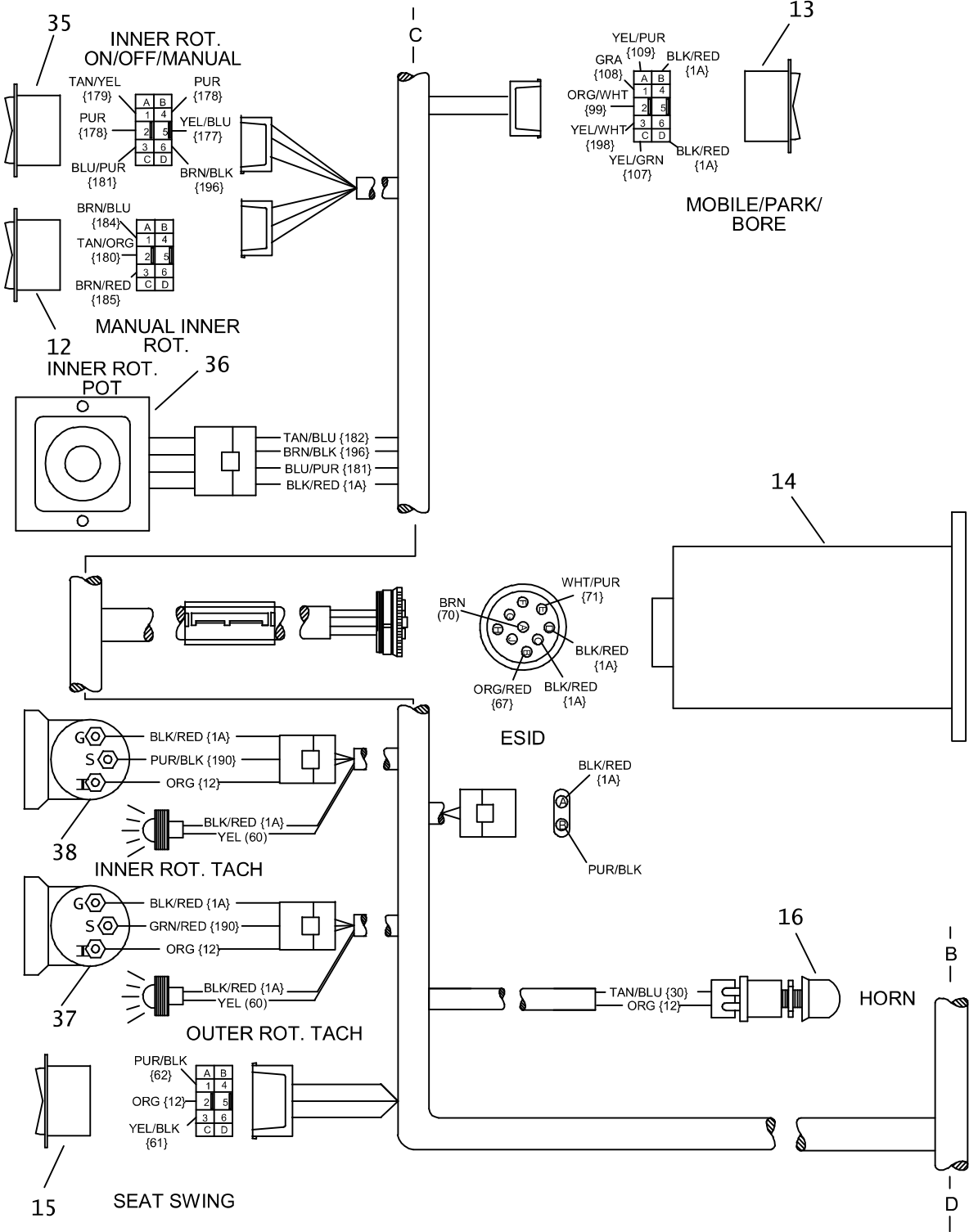

ELECTRICAL DIAGRAM OPERATOR STATION HARNESS

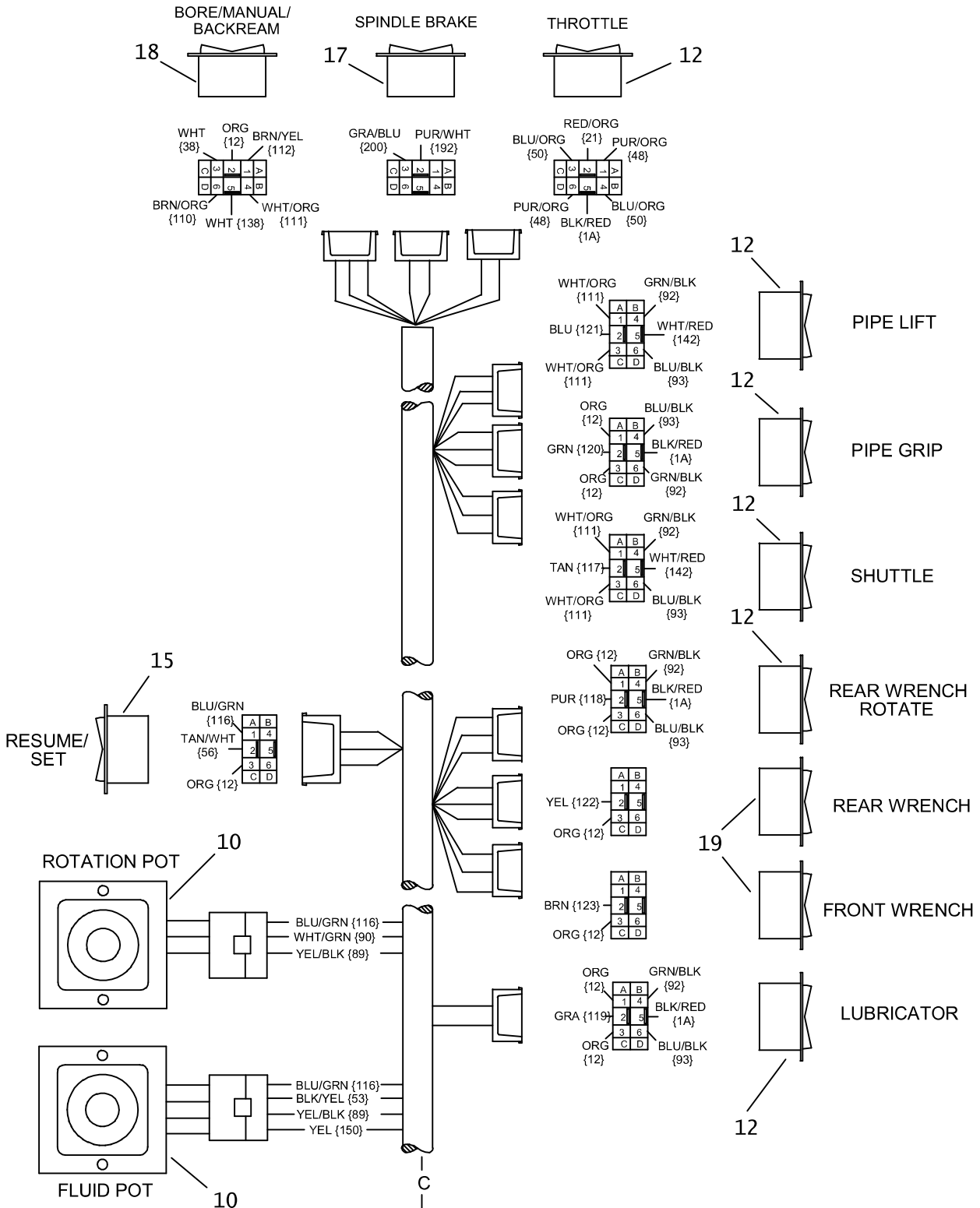

ELECTRICAL DIAGRAM OPERATOR STATION HARNESS

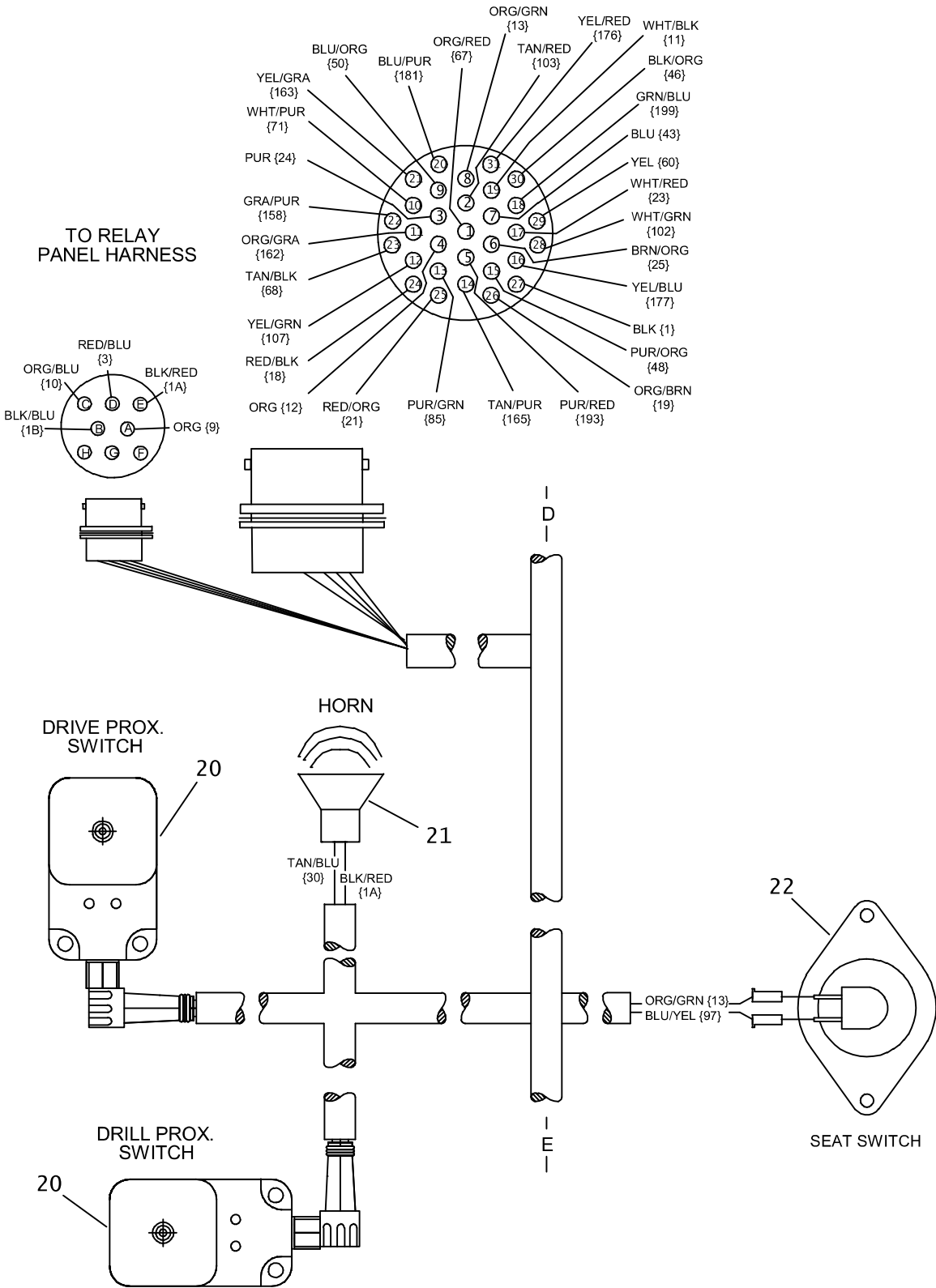

ELECTRICAL DIAGRAM OPERATOR STATION HARNESS

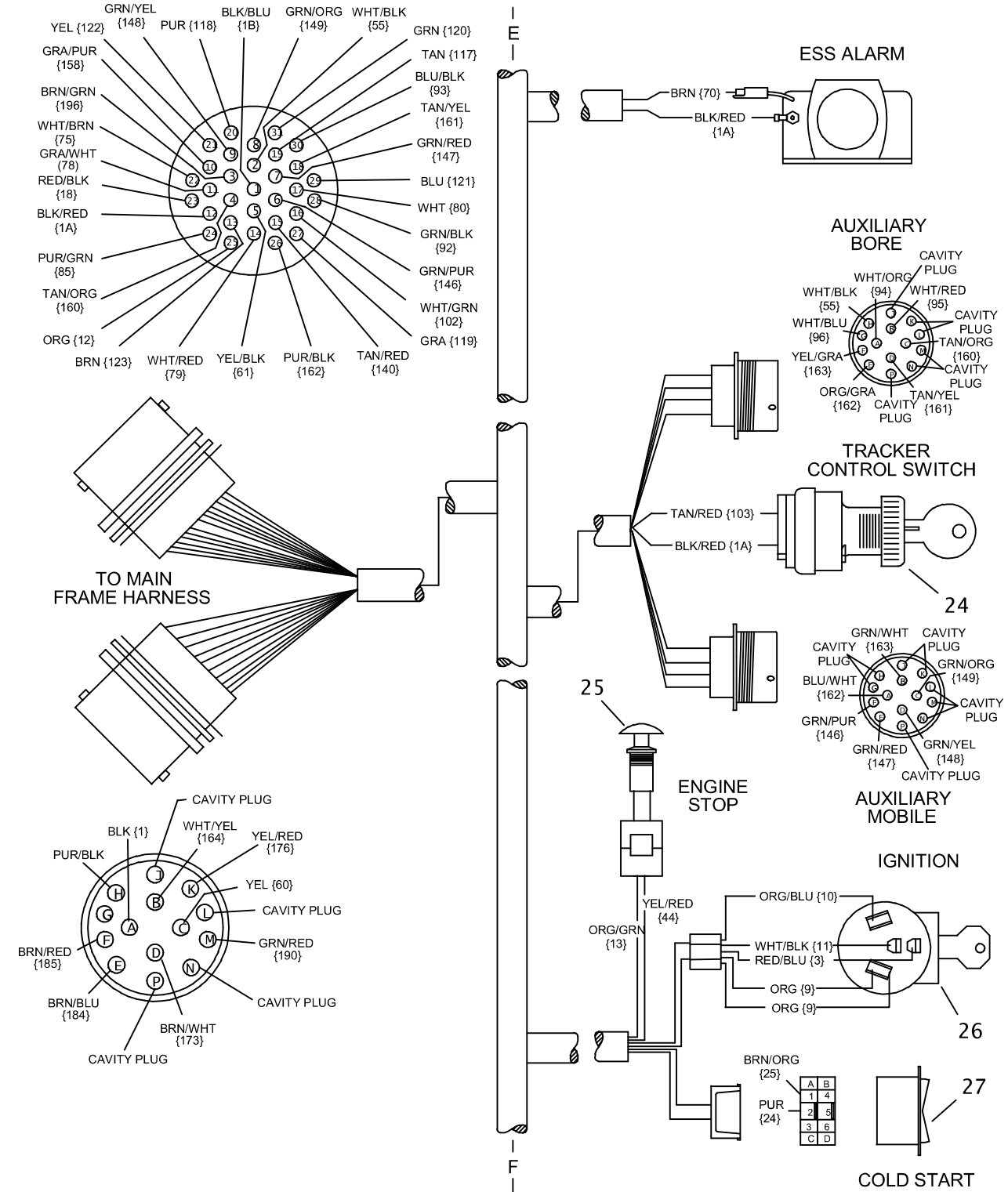

ELECTRICAL DIAGRAM OPERATOR STATION HARNESS

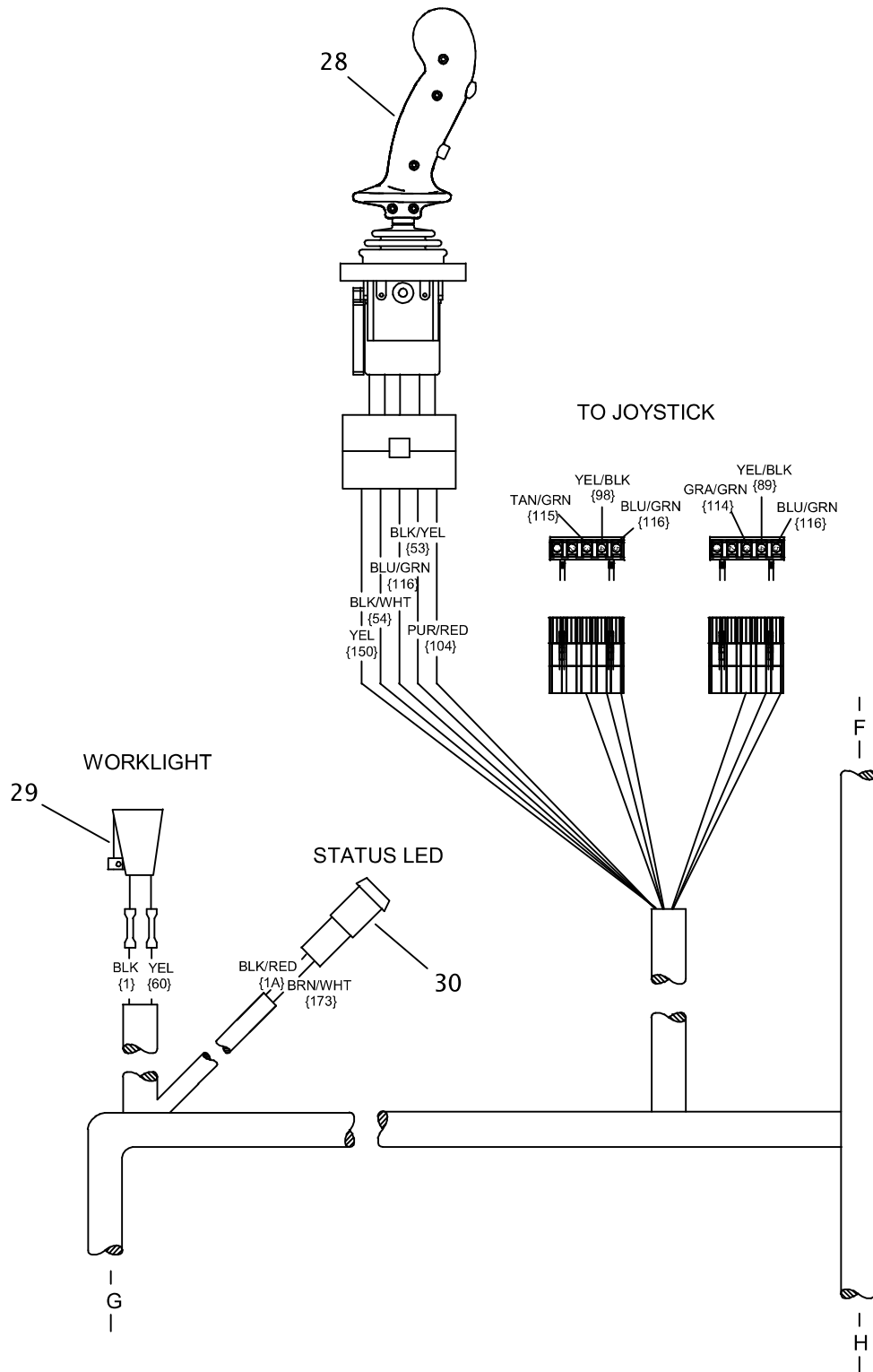

ELECTRICAL DIAGRAM OPERATOR STATION HARNESS

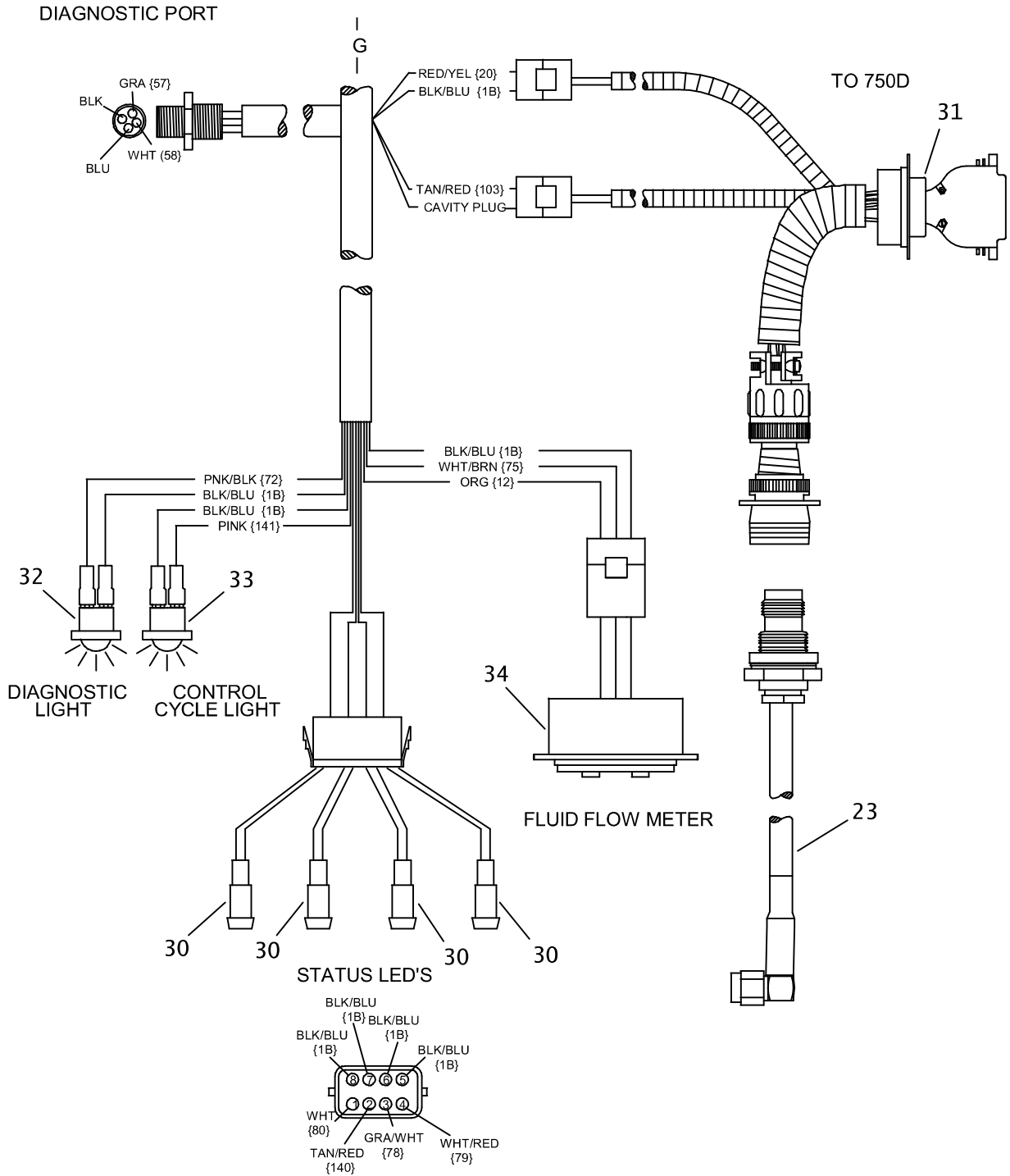

ELECTRICAL DIAGRAM OPERATOR STATION HARNESS

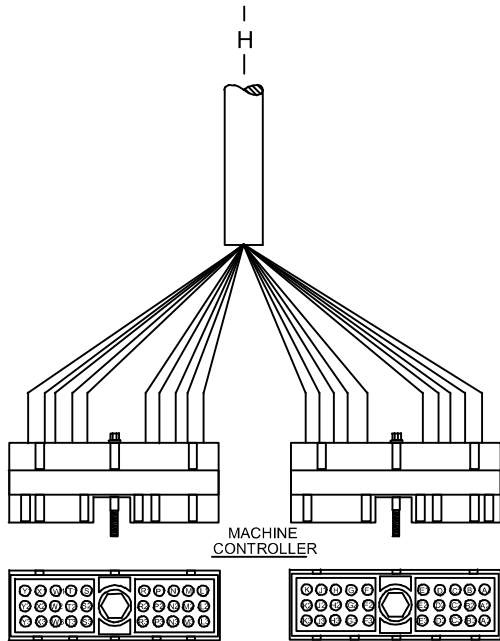

L1	GRA/ORG {83}	S1	BRN/GRN {196}
L2	CAVITY PLUG	S2	TAN/BLK {113}
L3	TAN/WHT {56}	S3	PNK/WHT {58}
M1	GRAY/YEL {84}	T1	BRN/BLU {184}
M2	CAVITY PLUG	T2	PNK/BLU {57}
M3	NO CONNECTION	T3	BLU/GRN {116}
N1	BLU/ORG {81}	W1	BRN/RED {185}
N2	CAVITY PLUG	W2	YEL/BLK {89}
N3	WHT/PUR {71}	W3	BLK/BLU {18}
P1	BLU/YEL {82}	X1	BLU/BLK {93}
P2	CAVITY PLUG	X2	RED/BLU {17}
P3	TAN/BLU {182}	X3	BLK/BLU {18}
R1	BRN/WHT {173}	Y1	GRN/BLK {92}
R2	PUR/BLK	Y2	RED/GRN {16}
R3	NO CONNECTION	Y3	RED/GRN {16}

A1	BRN {123}	F1	GRA {119}
A2	PUR/GRN {85}	F2	GRA/WHT {78}
A3	WHT/BLK {55}	F3	CAVITY PLUG
B1	YEL {122}	G1	TAN {117}
B2	YEL/PUR {109}	G2	TAN/RED {140}
B3	TAN/GRN {115}	G3	WHT/GRN {190}
C1	PUR/ORG {105}	H1	PUR {118}
C2	YEL/GRN {107}	H2	WHT/RED {79}
C3	GRA/GRN {114}	H3	CAVITY PLUG
D1	BLU {121}	J1	PNK {141}
D2	BRN/YEL {112}	J2	WHT {80}
D3	CAVITY PLUG	J3	CAVITY PLUG
E1	GRN {120}	K1	CAVITY PLUG
E2	BRN/ORG {110}	K2	NO CONNECTION
E3	BLK/WHT {54}	K3	PUR/RED {104}

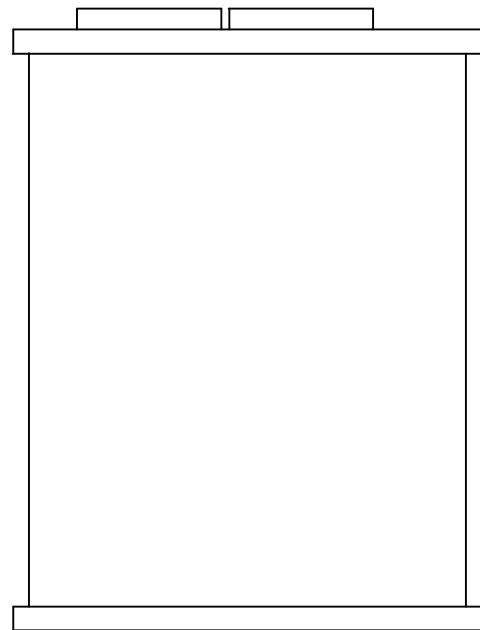

11

ELECTRICAL DIAGRAM OPERATOR STATION HARNESS

REF NO.	PART NUMBER	QTY	DESCRIPTION	REMARKS
1.	217-253	1	OPERATOR STATION HARNESS	
2.	214-502	1	DELAY TIMER	
3.	217-184	1	DELAY TIMER (2-SECOND)	
4.	217-809	2	FUSE (ATC, 5 AMP)	
5.	217-811	3	FUSE (ATC, 15 AMP)	
6.	217-812	3	FUSE (ATC, 20 AMP)	
7.	217-710	10	MICRO RELAY (SPDT)	
8.	211-031	1	BORE/MOBILE RESISTOR PACK	
9.	211-026	1	DIODE PACK (DEUTSCH)	
10.	214-566	2	POTENTIOMETER	
11.	216-059	1	CONTROL MODULE	
12.	214-489	7	ROCKER SW (DPDT) (ON)-OFF-(ON)	SEE FOOTNOTE 1
13.	217-923	1	ROCKER SW (DPDT) ON-OFF-ON	
14.	217-241	1	ESID MODULE	
15.	217-911	2	ROCKER SWITCH (SPDT) ON-OFF-ON	
16.	306-607	1	HORN BUTTON	
	306-608	1	BUTTON COVER	
17.	217-918	1	ROCKER SW (DPDT) ON-ON	
18.	217-912	1	ROCKER SWITCH (DPDT) ON-ON-ON	
19.	217-907	2	ROCKER SWITCH (DPDT) ON-ON	
20.	214-692	2	PROXIMITY SWITCH	
21.	192-006	1	HIGH FREQUENCY HORN	
	214-416	2	HORN (ELECTRIC)	OBSOLETE
22.	217-750	1	SEAT SWITCH	
23.	214-413	1	RIG RF CABLE 2130MM	
24.	214-908	1	ON-OFF KEY SWITCH	
25.	217-206	1	BUTTON SWITCH (SPST)	
26.	214-852	1	IGNITION SWITCH	
27.	217-917	1	ROCKER SWITCH (DPDT) OFF-(ON)	
28.	215-1224	1	DUAL AXIS JOYSTICK	
29.	217-007	1	WORKING LIGHT (CLEAR, RECT)	
30.	214-701	5	STATUS LIGHT	
31.	214-415	1	90D MODULE TO RIG CABLE	
32.	214-564	1	GREEN LED (12V DC)	
33.	214-563	1	RED LED 12V	
34.	217-221	1	FLOW METER DISPLAY	
35.	217-908	1	ROCKER SWITCH (DPDT) ON-ON-ON	AT ONLY
	110-962	1	FILLER PLUG	JT ONLY
36.	211-089	1	4.5V-12.0V POTENTIOMETER	AT ONLY
	214-247	1	MALE CONNECTOR (4-WAY)	JT ONLY
	211-060	4	WP CAVITY PLUG	JT ONLY
37.	217-561	1	SPINDLE TACHOMETER (250 RPM)	AT ONLY
	215-225	1	3-WAY WP FEMALE CONNECTOR	JT ONLY
NOT SHOWN	211-060	3	WP CAVITY PLUG	JT ONLY
38.	211-099	1	SPINDLE TACHOMETER (250 RPM)	AT ONLY
	215-225	1	3-WAY WP FEMALE CONNECTOR	JT ONLY
	211-060	3	WP CAVITY PLUG	JT ONLY

FOOTNOTES:

- INNER ROTATION SWITCH REPLACED BY 110-962 FOR JT4020 MACH 1

NOTE:

ELECTRICAL DIAGRAM MAIN FRAME HARNESS

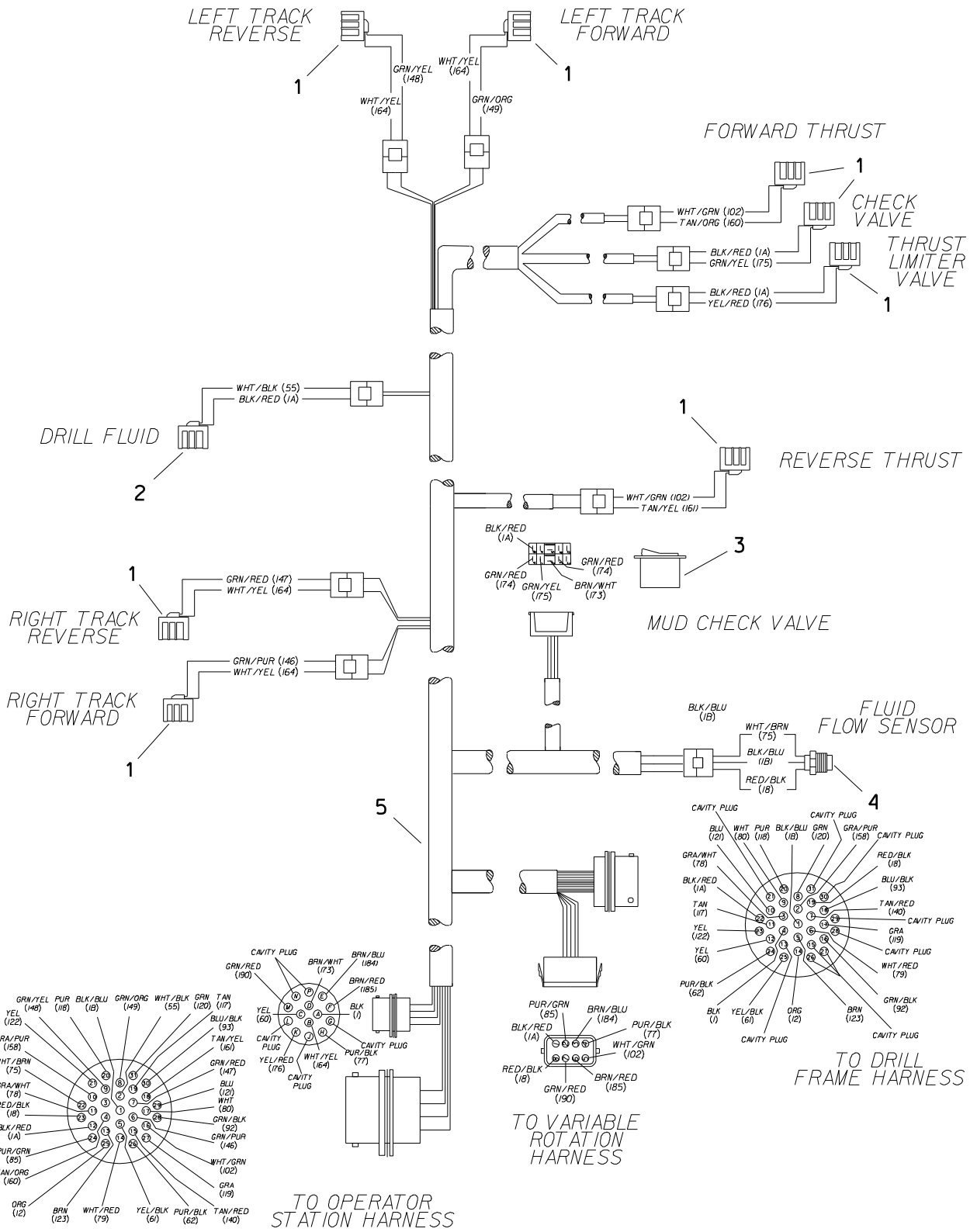

ELECTRICAL DIAGRAM MAIN FRAME HARNESS

REF NO.	PART NUMBER	QTY	DESCRIPTION	REMARKS
1.	214-434	8	SOLENOID COIL (SMALL)	SEE FOOTNOTE 1
2.	217-897	1	SOLENOID COIL (LARGE)	
3.	217-918	1	ROCKER SW (DPDT) ON-ON	
	217-925	1	ROCKER SWITCH (ACTUATOR)	
	217-137	1	ICON (WHT) OFF-STOP	
	217-158	1	DIFFUSION LENS (WHITE)	
	217-136	1	ICON (WHT) ON-START	
	217-156	1	DIFFUSION LENS (GREEN)	
4.	216-047	1	SPEED PICKUP	
5.	217-255	1	AT/JT MAIN FRAME HARNESS	

FOOTNOTES

1. THRUST LIMITER SOLENOID REPLACED BY 214-209 IN JT4020 MACH 1

ELECTRICAL DIAGRAM WORK LIGHT HARNESS

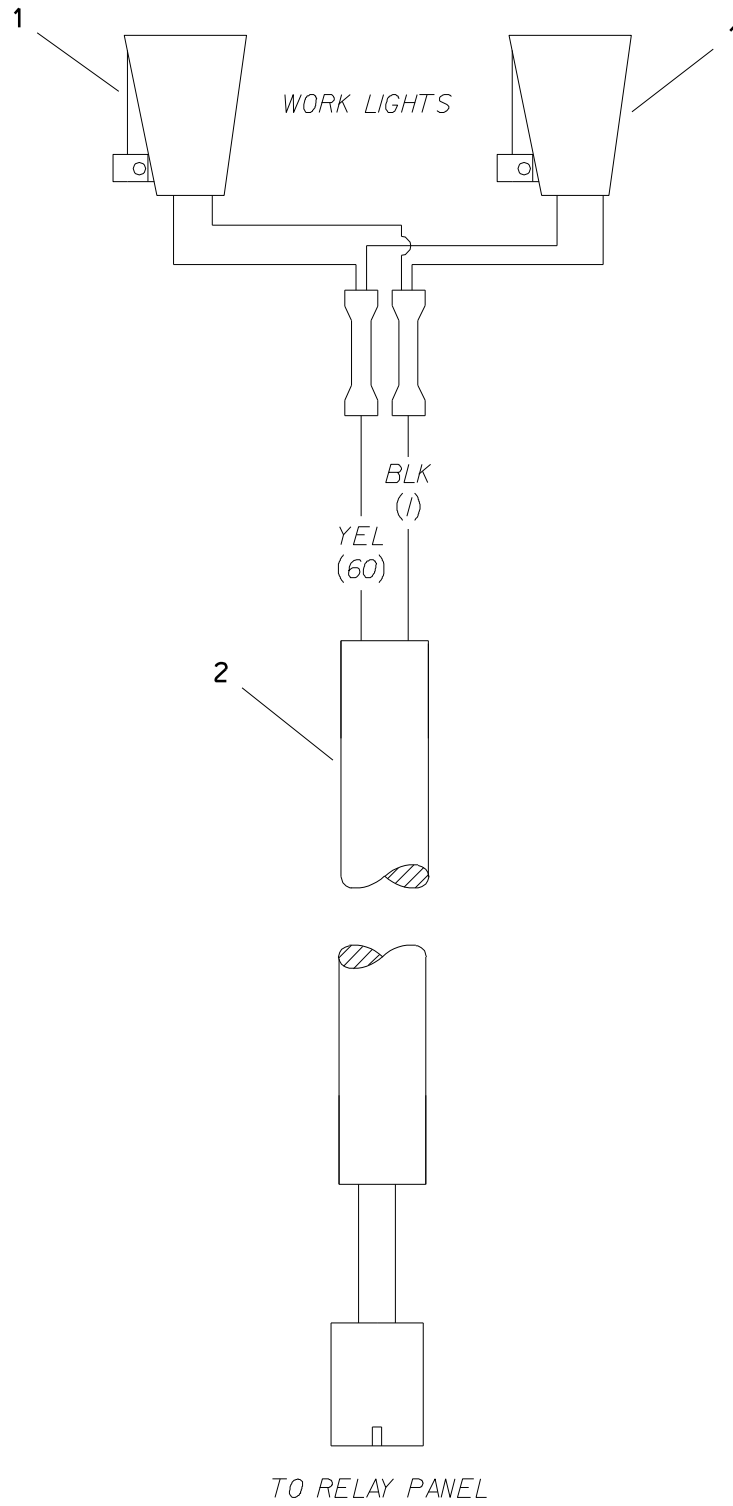

ELECTRICAL DIAGRAM WORK LIGHT HARNESS

REF NO.	PART NUMBER	QTY	DESCRIPTION	REMARKS
1.	217-057	2	WORKING LIGHT - CLEAR	
2.	214-763	1	WORK LIGHT HARNESS	

FOOTNOTES

ELECTRICAL DIAGRAM DRILL FRAME HARNESS

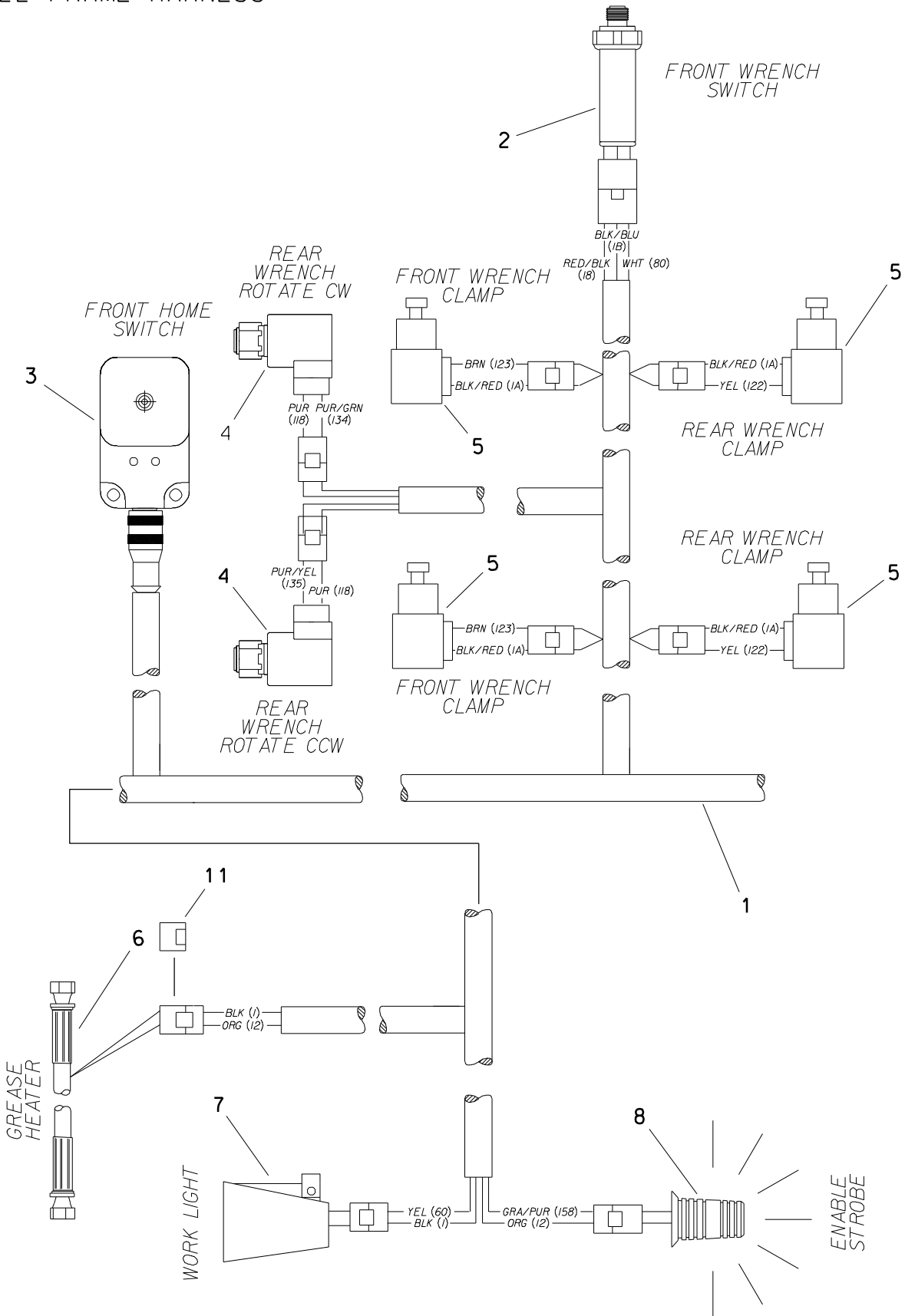

ELECTRICAL DIAGRAM DRILL FRAME HARNESS

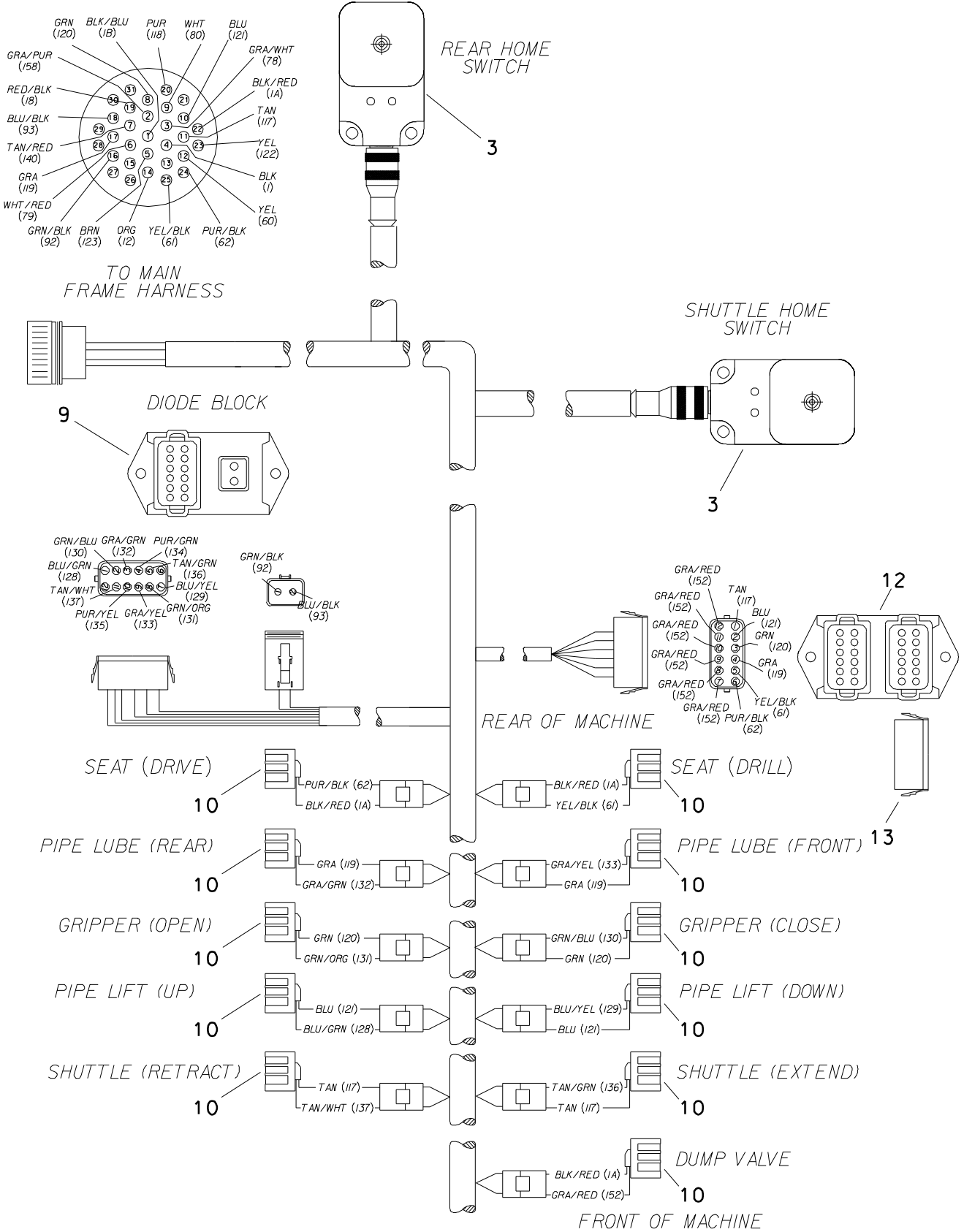

B

ELECTRICAL DIAGRAM

DRILL FRAME HARNESS

REF NO.	PART NUMBER	QTY	DESCRIPTION	REMARKS
1.	214-968	1	DRILL FRAME HARNESS	
2.	214-645	1	PRESSURE SWITCH (500PSI)	
3.	214-692	3	PROXIMITY SWITCH	
4.	499-310	2	SOLENOID COIL	
5.	217-897	4	SOLENOID COIL (LARGE)	
6.	153-585	1	HOSE (06QFX-18"-3000, SPCL)	
7.	217-007	1	WORKING LIGHT (CLEAR, RECT)	
8.	214-697	1	STROBE LIGHT (12V. DC, GREEN)	
9.	211-025	1	IN-LINE DIODE PACK	
10.	214-435	11	SOLENOID COIL (12V)	
11.	214-209	1	2-WAY MALE CAP	
12.	211-026	1	DIODE PACK (DEUTSCH)	
13.	214-781	1	12 WAY PLUG	

FOOTNOTES

ELECTRICAL DIAGRAM

PULLBACK STOP HARNESS

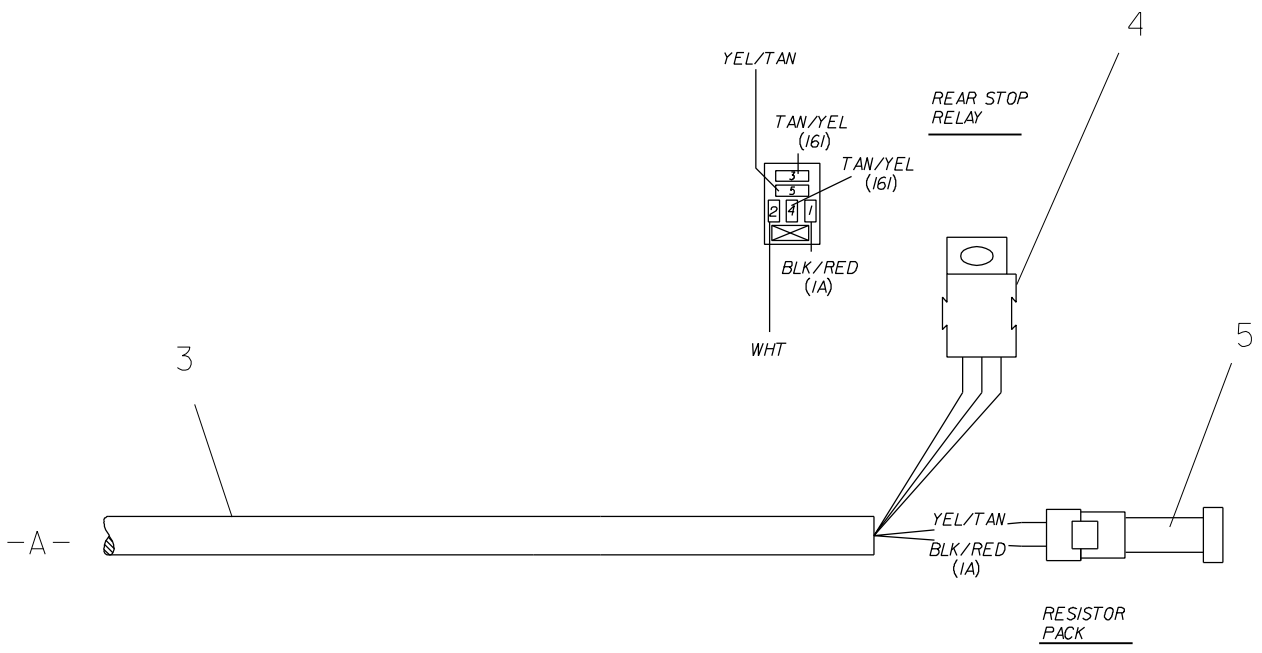

ELECTRICAL DIAGRAM

PULLBACK STOP HARNESS

REF. NO.	PART NUMBER	QTY.	DESCRIPTION
1.	214-692	1	PROXIMITY SWITCH
2.	214-434	1	SOLENOID COIL (SMALL)
3.	213-103	1	AT/JT42M1 REARSTOP HARNESS
4.	217-710	1	MICRO RELAY (SPDT)
5.	211-279	1	INNER ROTATION RESISTOR PACK

ELECTRICAL DIAGRAM

PULLBACK STOP HARNESS

REV. THRUST SOLENOID

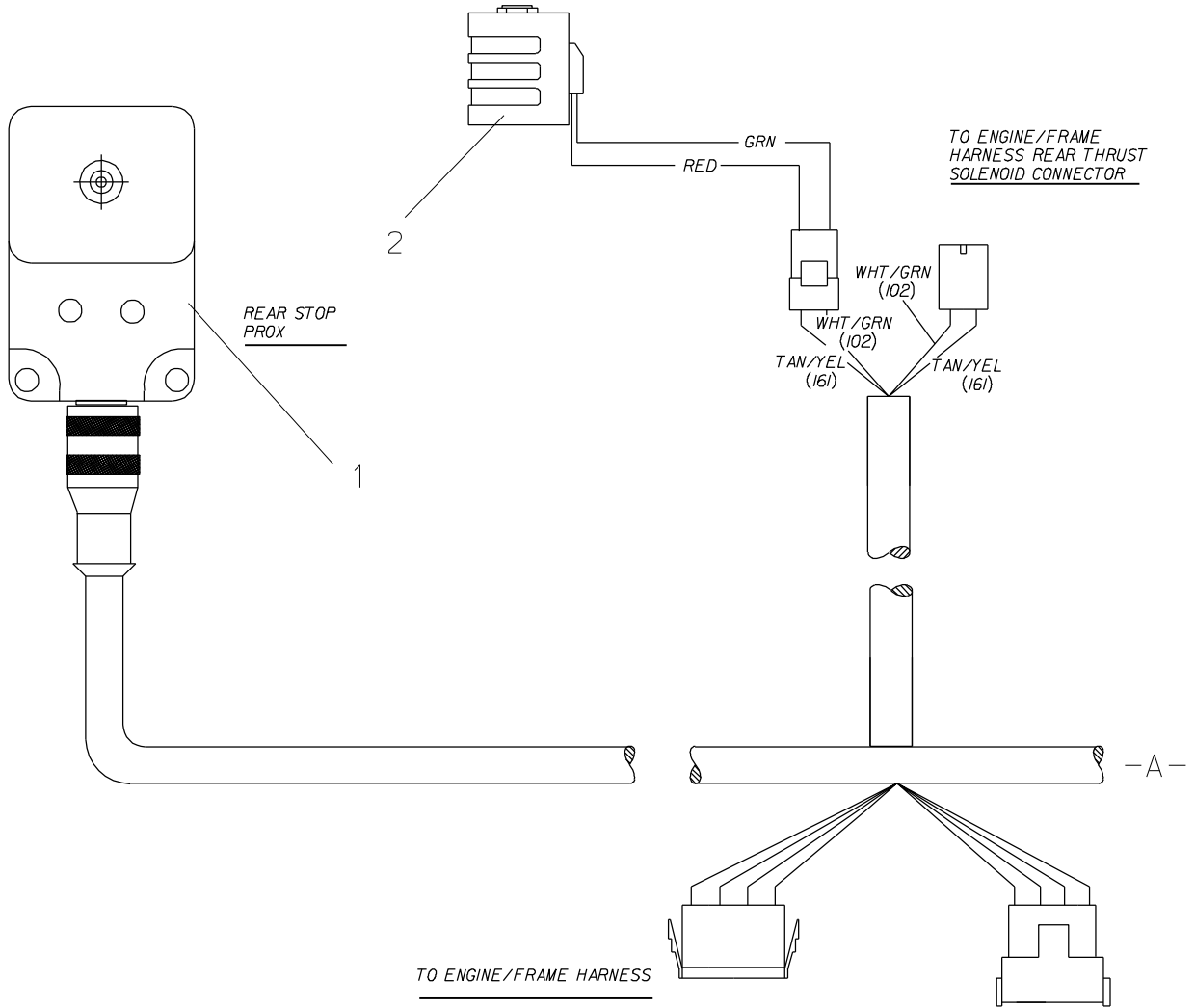

TO ENGINE/FRAME HARNESS

TO DRILL FRAME HARNESS

PIN #		PIN #	
1	BLK/RED (1A)	5	WHT/GRN (102)
2	PUR/GRN (85)	6	BRN/RED (185)
3	BRN/BLU (184)	7	GRN/RED (190)
4	PUR/BLK	8	RED/BLK (18)

PIN #		PIN #	
1	BLK/RED (1A)	5	WHT/GRN (102)
2	PUR/GRN (85)	6	BRN/RED (185)
3	BRN/BLU (184)	7	GRN/RED (190)
4	PUR/BLK	8	RED/BLK (18)

DITHER ASSIST HARNESS

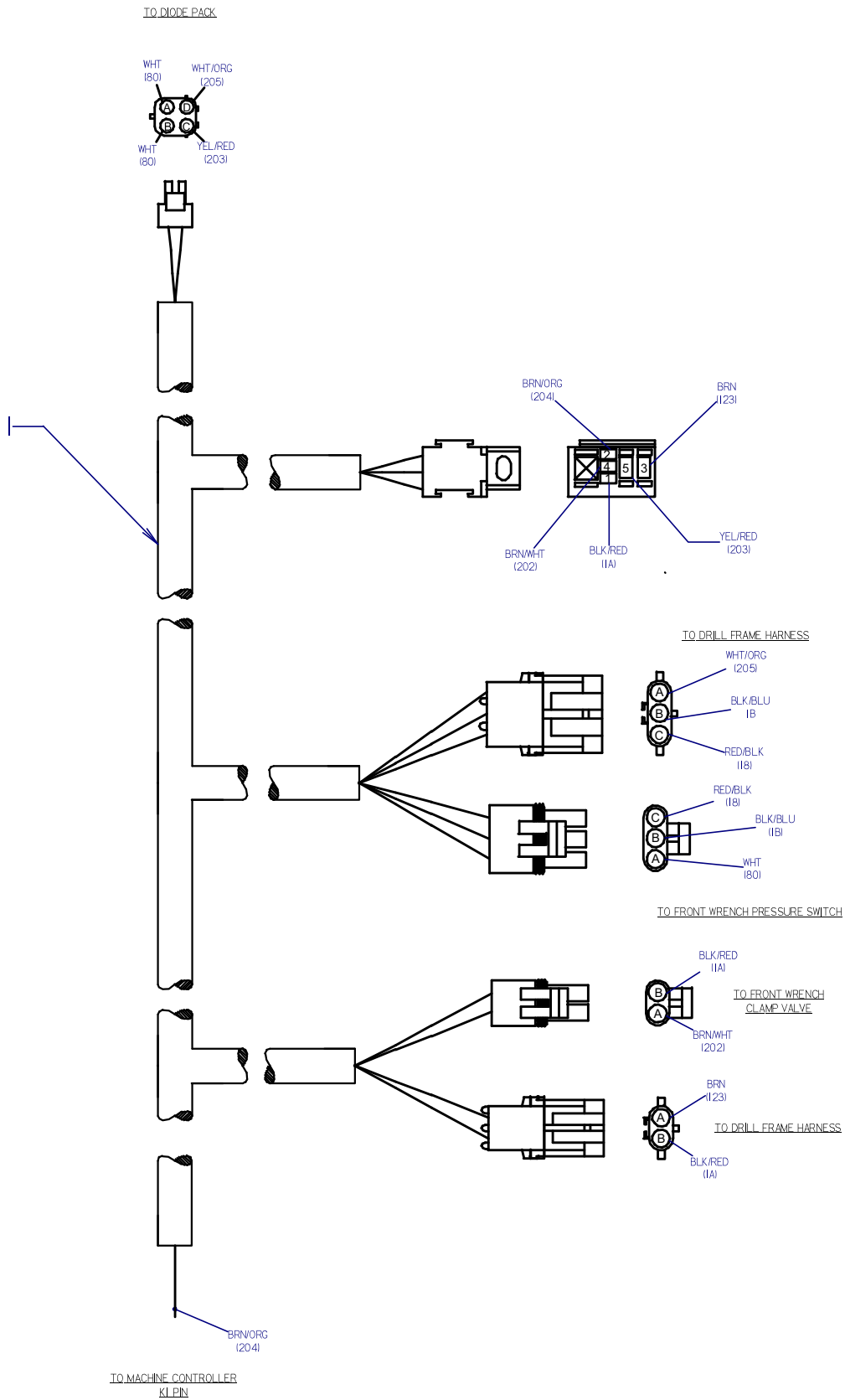

DITHER ASSIST HARNESS

REF NO.	PART NUMBER	QTY	DESCRIPTION	REMARKS
I.	213-251	1	DITHER ASSIST HARNESS	FOR USE ON THE AT42MI ONLY

FOOTNOTES

NOTE:

B

809-189

ELECTRICAL DIAGRAM ROTATION HARNESS

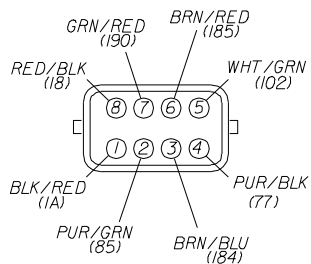
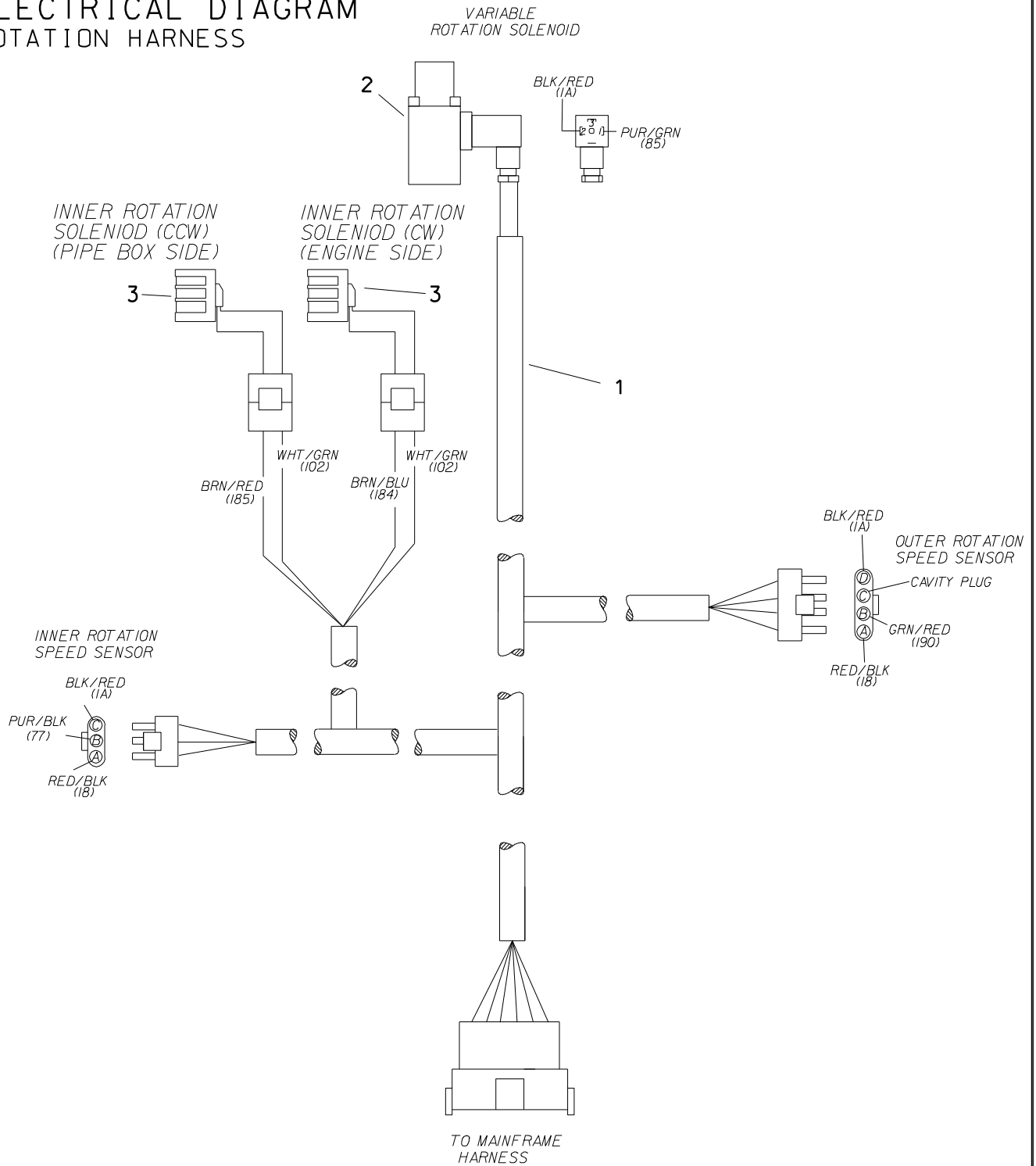

ELECTRICAL DIAGRAM ROTATION HARNESS

REF NO.	PART NUMBER	QTY	DESCRIPTION	REMARKS
1.	217-257	1	AT/JT ROTATION HARNESS	
2.	217-745	1	CONTROL SOLENOID	
3.	214-434	2	SOLENOID COIL (SMALL)	

FOOTNOTES

ELECTRICAL STRIKE SYSTEM

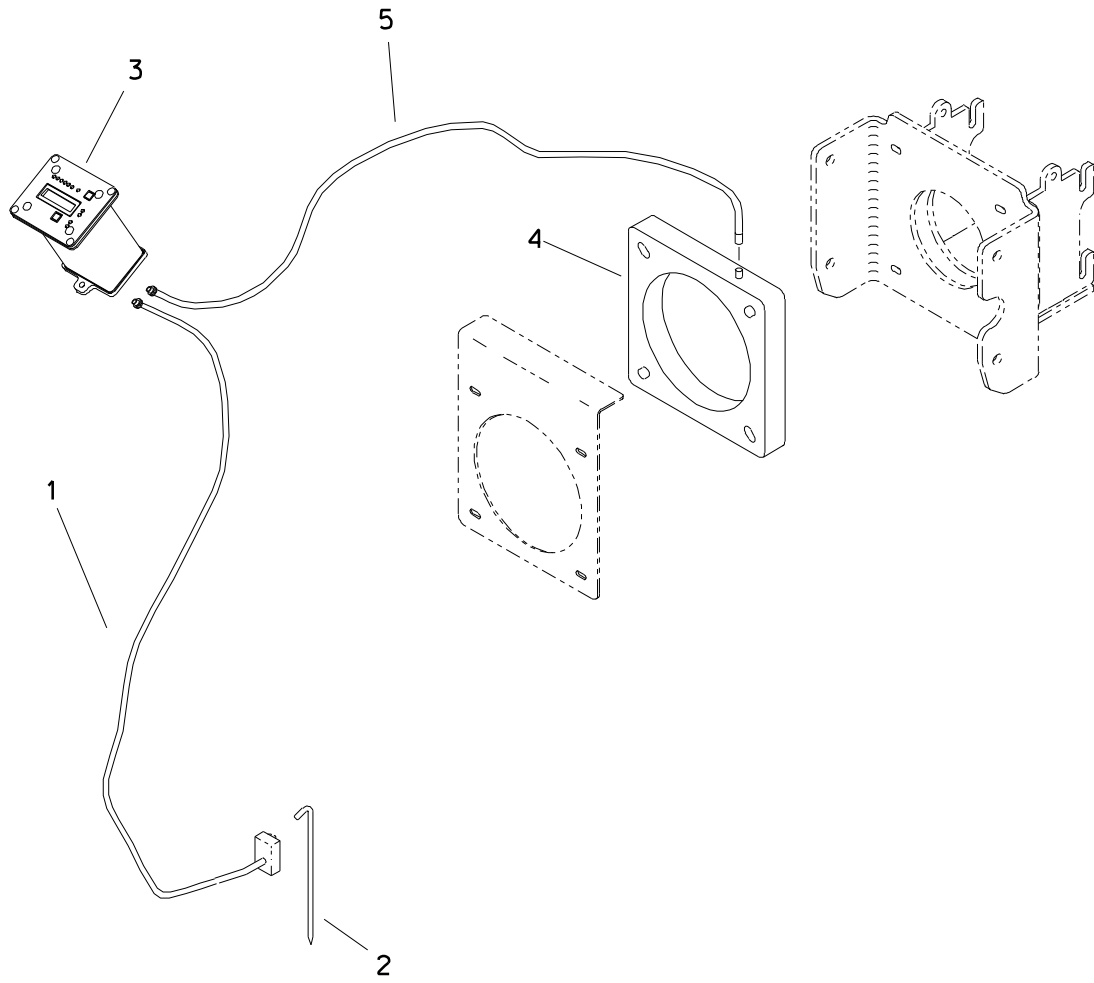

ELECTRICAL STRIKE SYSTEM

REF NO.	PART NUMBER	QTY	DESCRIPTION	REMARKS
1.	211-042	1	VOLTAGE LIMITER CABLE	
2.	215-799	1	VOLTAGE STAKE	
3.	217-241	1	ESID MODULE	
	197-079	-	REBUILT ESID MODULE 217-241	
4.	216-063	1	CURRENT TRANSFORMER	
5.	214-542	1	CURRENT COIL CABLE	

FOOTNOTES

RIGHT CONSOLE

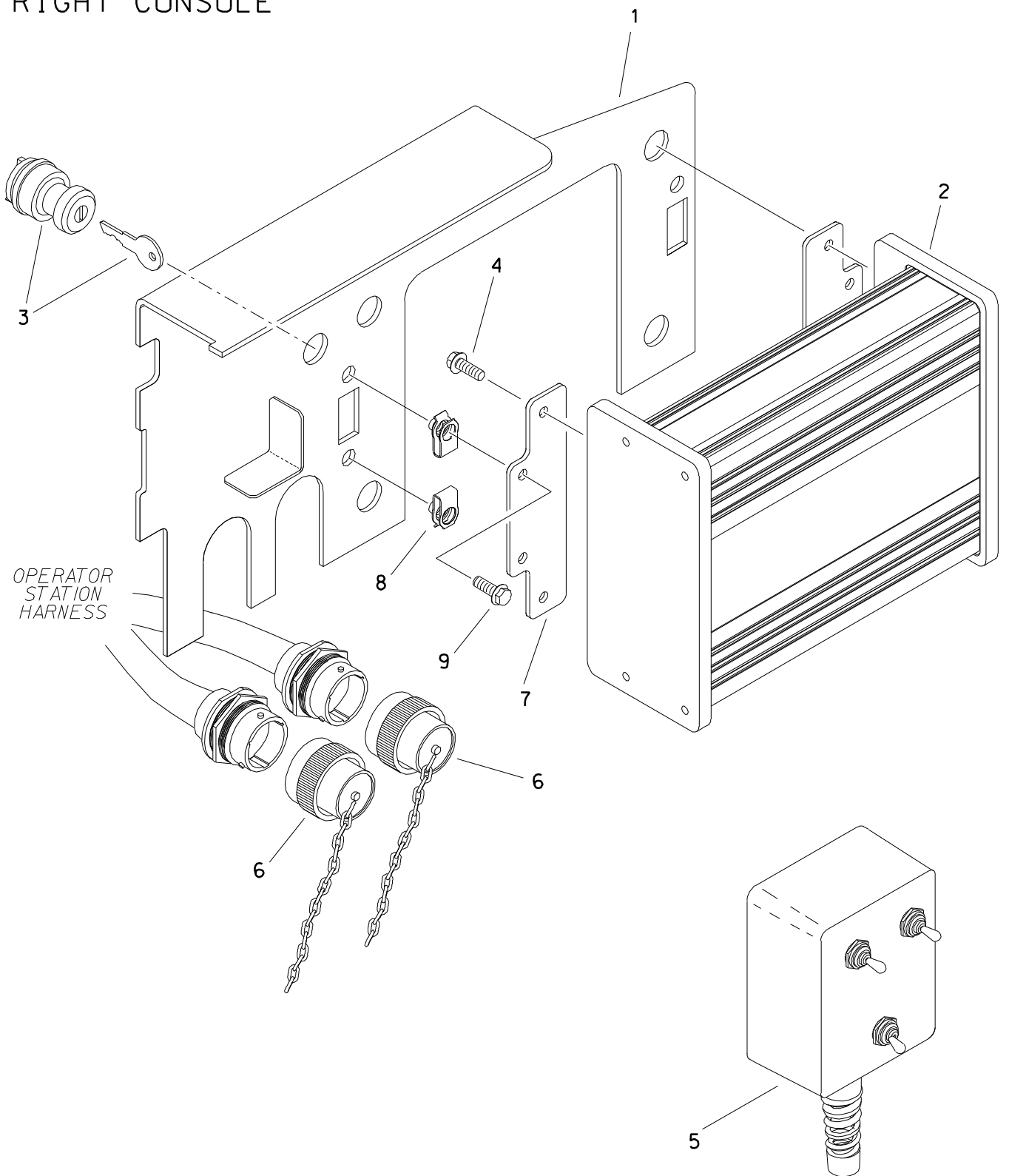

RIGHT CONSOLE

REF NO.	PART NUMBER	QTY	DESCRIPTION	REMARKS
1.	313-733	-	OPERATOR FRAME	
2.	216-059	-	CONTROL MODULE	
3.	217-248	-	OFF-ON KEY SWITCH	
	214-908	-	ON-OFF KEY SWITCH	
4.	106-378	4	FLG LK SCREW (M6-1.00 X 12MM)	
5.	214-648	1	OVERRIDE CONTROL BOX	
6.	214-812	2	PROTECTIVE CAP	
7.	316-791	2	MOUNTING BRACKET	
8.	106-574	3	CLIP NUT (M6-1.00)	
9.	106-988	3	FLG LK SCREW (M6-1.00 X 20MM)	

FOOTNOTES

BATTERY

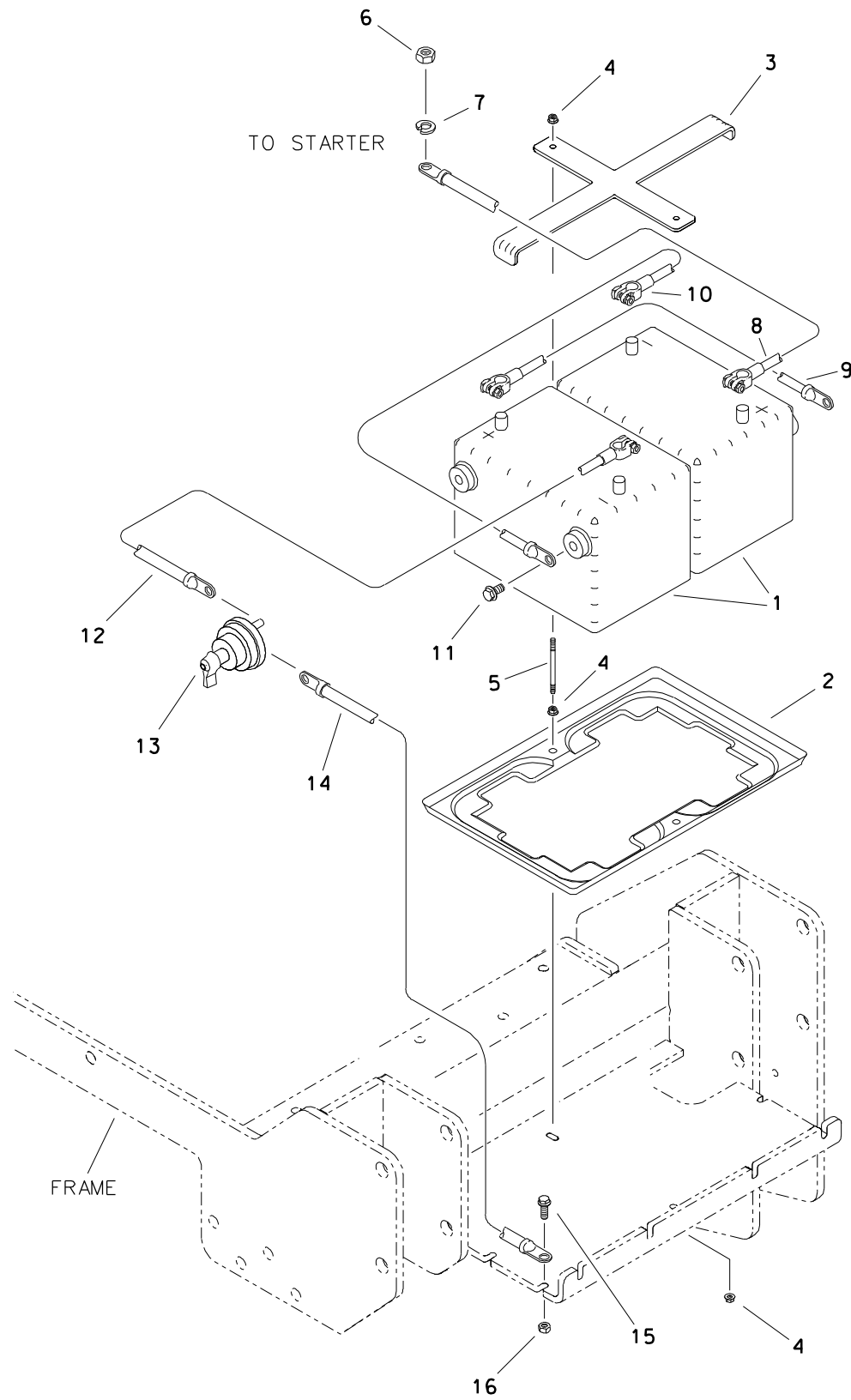

BATTERY

REF NO.	PART NUMBER	QTY	DESCRIPTION	REMARKS
1.	215-244	2	BATTERY	
2.	362-784	1	BATTERY TRAY	
3.	347-857	1	DUAL BATTERY STRAP	
4.	105-832	6	FLG LOCKNUT (1/4-NC)	
5.	356-491	2	TIE-DOWN ROD (1/4-NC X 9.3")	
6.	105-044	1	JAM NUT (1/2-NC)	
7.	105-070	1	LOCK WASHER (1/2")	
8.	215-241	1	BAT CABLE (2/0 GA X 81.8", RED)	
9.	215-361	1	BAT CABLE (2 GA X 23.6", RED)	
10.	215-360	1	BAT CABLE (2 GA X 23.6", BLK)	
11.	106-384	2	FLG LK BOLT (3/8-NC X 3/8")	
12.	215-337	1	BAT CABLE (2/0 GA X 19", BLK)	
13.	217-819	1	BAT DISCONNECT SWITCH	
14.	215-314	1	BAT CABLE (1/0 GA X 22", BLK)	
15.	106-381	1	FLG LK SCREW (M8-1.25 X 25MM)	
16.	106-561	1	LOCKNUT (M8-1.25, PRV TRQ, 10.9)	

FOOTNOTES

RELAY PANEL

JT4020 ALL TERRAIN ONLY

REF NO.	PART NUMBER	QTY	DESCRIPTION	REMARKS
1.	310-873	1	RELAY PANEL	
2.	310-981	1	BRACKET	
3.	106-048	12	LOCKNUT (#10-24)	
4.	105-185	8	BOLT (#10-24 X 1/2", RD SLT)	
5.	211-026	-	DIODE PACK (DEUTSCH)	
6.	217-252	-	AT/JT RELAY PANEL	PART OF WIRING HARNESS
	217-710	-	MICRO RELAY (SPDT)	
	217-826	-	MINI RELAY (SPDT)	
7.	106-049	4	BOLT (#10-24 X 3/4", PLPS)	
8.	106-378	1	FLG LK SCREW (M6-1.00 X 12MM)	
9.	110-333	1	BOLT-ON CLAMP (1")	
10.	217-937	-	START BYPASS DELAY TIMER	
11.	106-237	1	LOCKNUT (M6-1.00, PRV TRQ, NLK)	
12.	106-991	5	FLG LK SCREW (M8-1.25 X 20MM)	
13.	309-549	1	BRACKET	
14.	106-551	1	CLIP NUT (M8-1.25)	
15.	214-781	1	12 WAY PLUG	
16.	107-095	1	FLG SCREW (M8-1.25 X 16MM)	

FOOTNOTES

LEFT CONSOLE RELAY PANEL

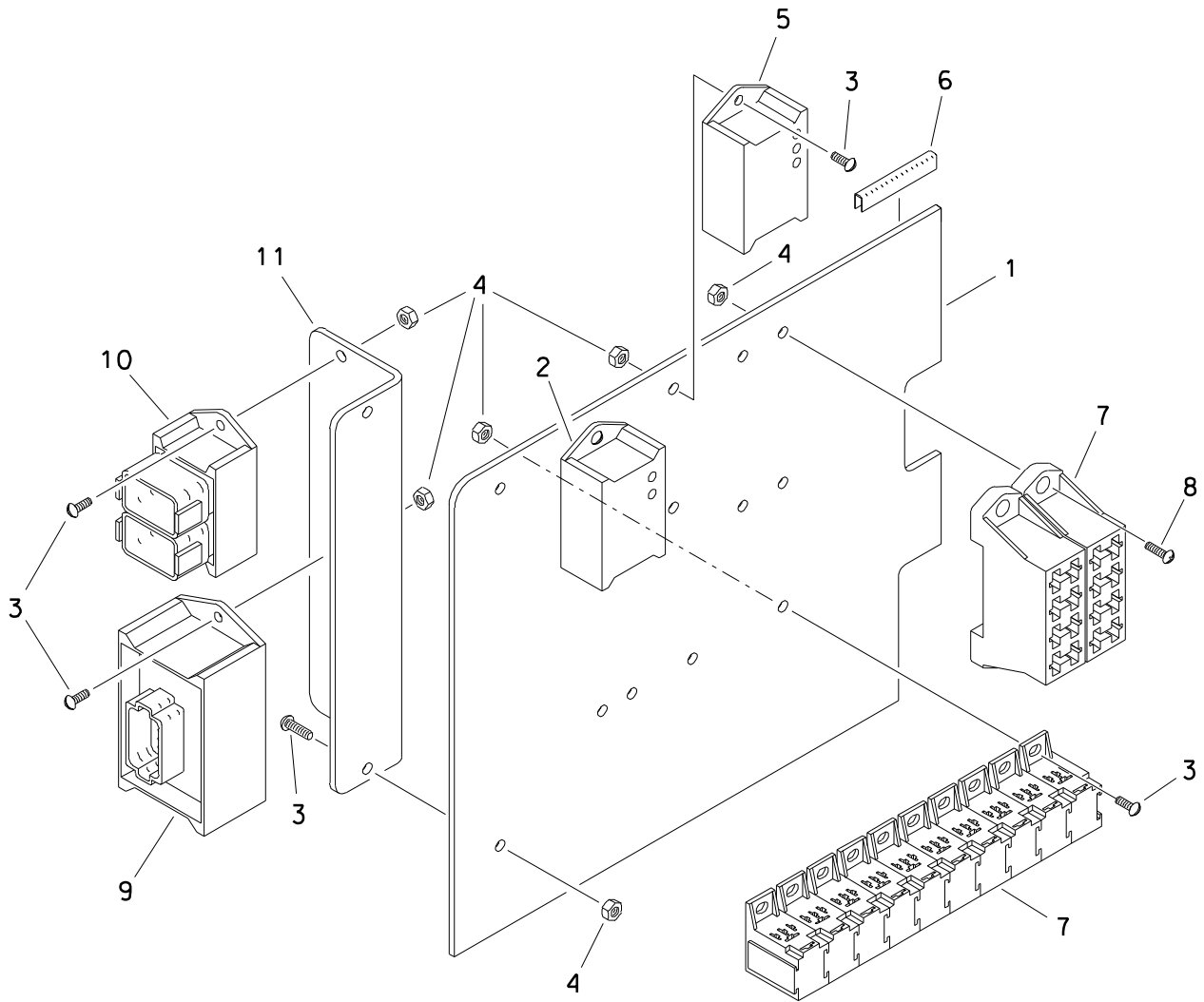

LEFT CONSOLE RELAY PANEL

REF NO.	PART NUMBER	QTY	DESCRIPTION	REMARKS
1.	313-733	-	OPERATOR FRAME	
2.	214-502	-	DELAY TIMER	ESID TIMER
3.	105-185	14	BOLT (#10-24 X 1/2", RD SLT)	
4.	106-048	18	LOCKNUT (#10-24)	
5.	217-184	-	DELAY TIMER (2-SECOND)	SEAT TIMER
6.	116-789	AR	RUBBER EDGE TRIM 1/8" (12 GA)	USE 1 @ 10.0"
7.	217-253	-	AT/JT OPERATOR STATION HARNESS	
8.	106-049	4	BOLT (#10-24 X 3/4", PLPS)	
9.	211-031	-	BORE/MOBILE RESISTOR PACK	
10.	211-026	-	DIODE PACK (DEUTSCH)	
11.	310-982	1	BRACKET	

FOOTNOTES

ENGINE GROUND

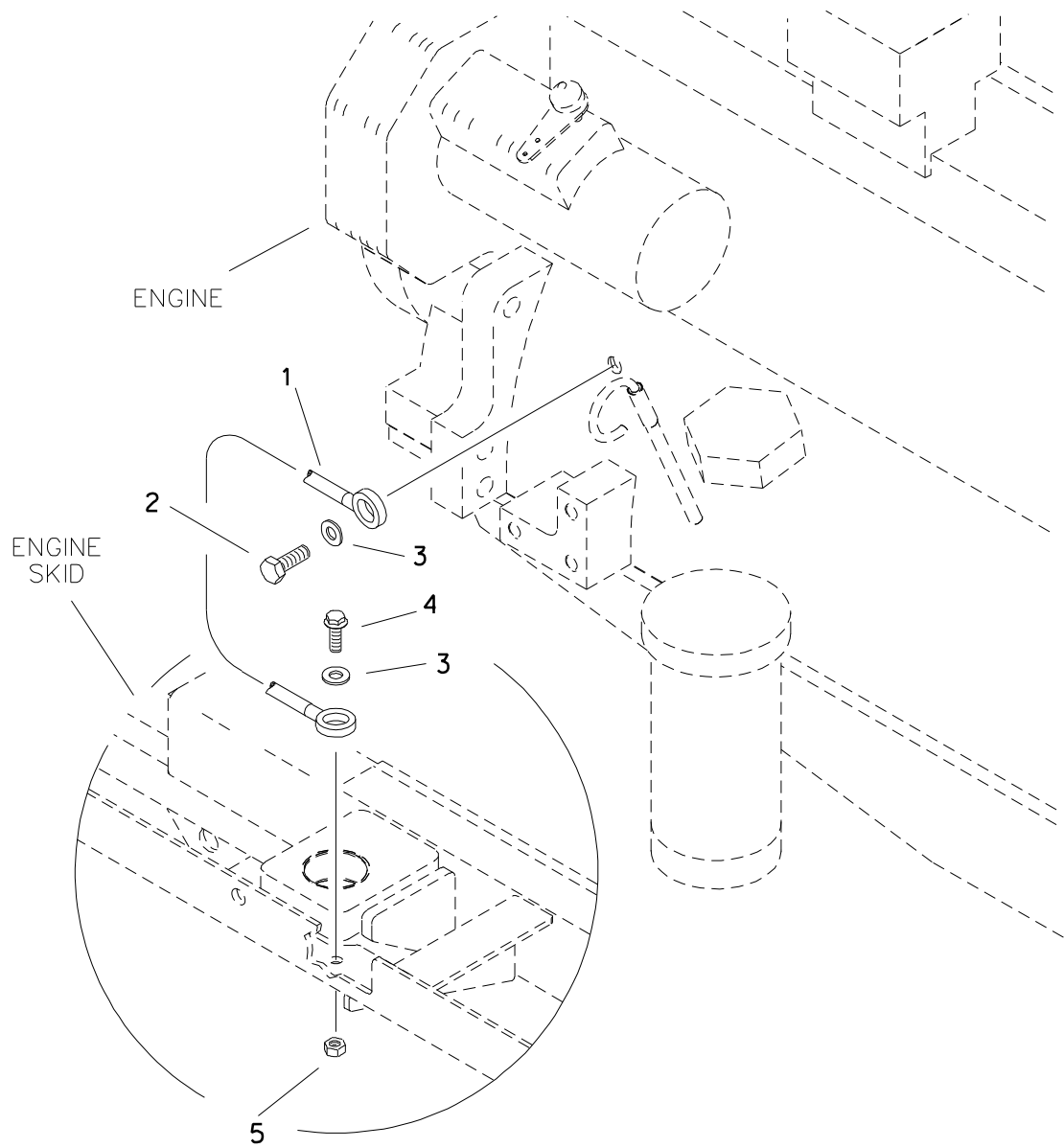

ENGINE GROUND

REF NO.	PART NUMBER	QTY	DESCRIPTION	REMARKS
1.	215-314	1	BAT CABLE (1/0 GA X 22", BLK)	SEE FOOTNOTE 1
2.	105-245	1	SCREW (M10-1.50 X 25MM)	
3.	105-118	2	WASHER (3/8")	
4.	106-162	1	FLG SCREW (M8-1.25 X 20MM)	
5.	106-561	1	LOCKNUT (M8-1.25,PRV TRQ,10.9)	

FOOTNOTES

1. REMOVE PAINT ON ENGINE SKID AND ENGINE BLOCK WHERE CABLE COMES INTO CONTACT.

ALARM AND STROBE LIGHT ELECTRICAL STRIKE SYSTEM

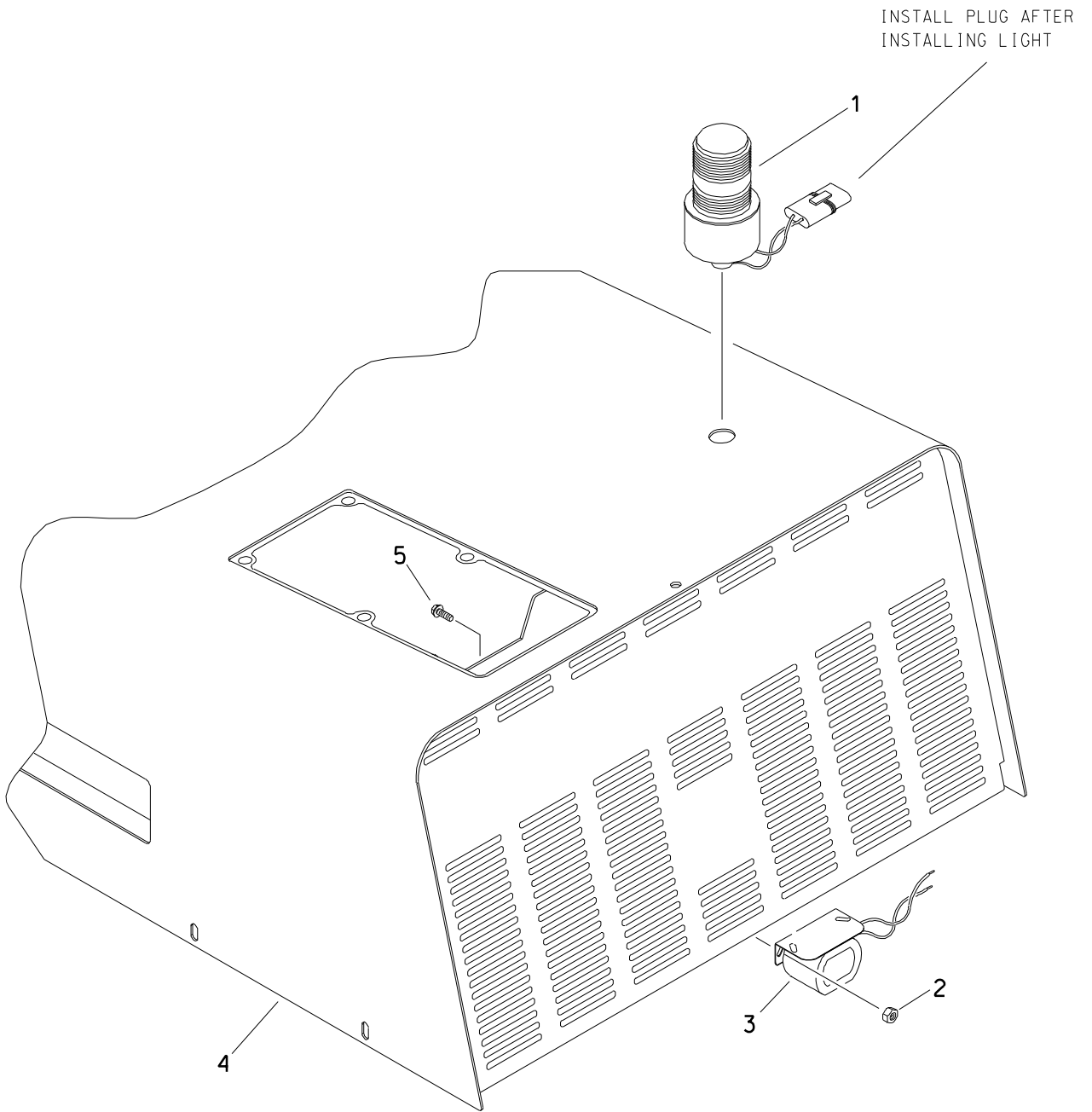

ALARM AND STROBE LIGHT ELECTRICAL STRIKE SYSTEM

REF NO.	PART NUMBER	QTY	DESCRIPTION	REMARKS
1.	214-722	1	STROBE LIGHT (AMBER)	INCL LENS & BULB
2.	106-561	2	LOCKNUT (M8-1.25, PRV TRQ, 10.9)	
3.	306-602	1	BACKUP ALARM	
4.	309-236	-	ENGINE PANEL (TOP)	
5.	106-162	2	FLG SCREW (M8-1.25 X 20MM)	

FOOTNOTES

ELECTRICAL DIAGRAM LOAD SENSE VALVE HARNESS

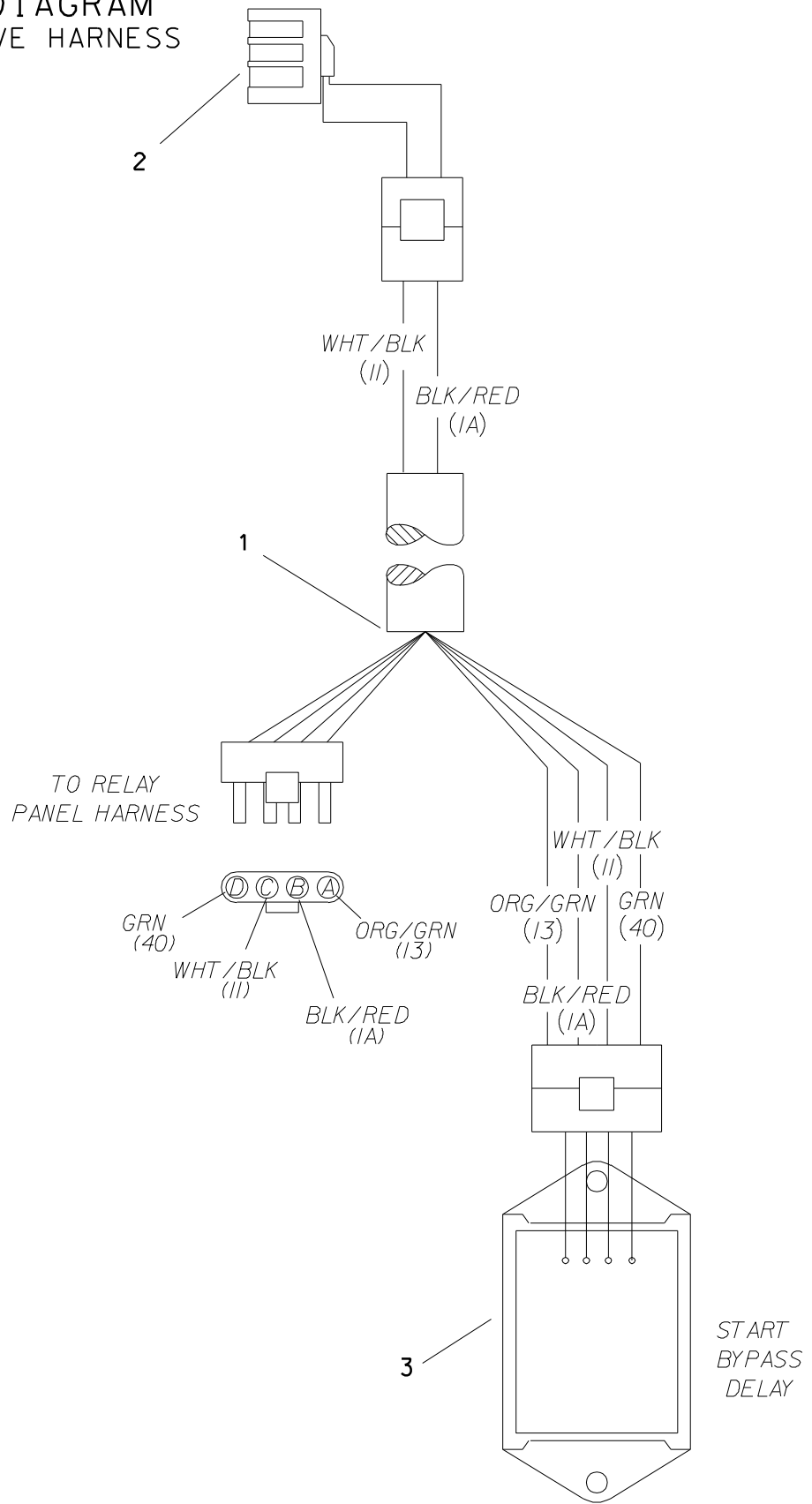

ELECTRICAL DIAGRAM

LOAD SENSE VALVE HARNESS

REF NO.	PART NUMBER	QTY	DESCRIPTION	REMARKS
1.	214-845	1	LOAD SENSE VALVE HARNESS	
2.	214-491	1	COIL, 12V	
3.	217-804	1	START BYPASS DELAY	

FOOTNOTES

ACCESSORIES

COLD START

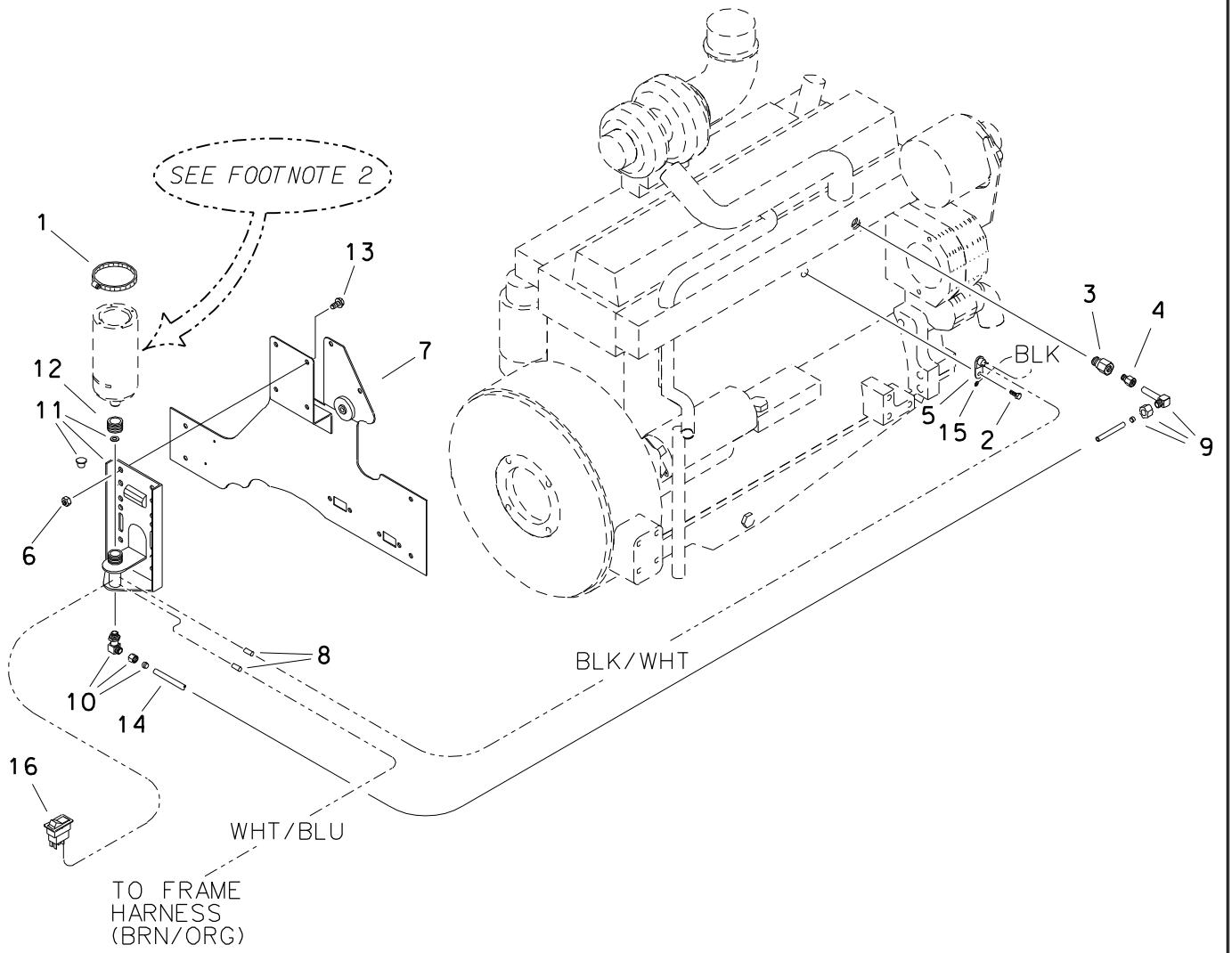

COLD START

REF NO.	PART NUMBER	QTY	DESCRIPTION	REMARKS
	101-073		COLD START KIT	INCL REF NOS. 1, 3-6, AND 8-16; SEE FOOTNOTE 1
1.	110-367	1	WORM CLAMP (3.250" TO 4.125")	
2.	105-245	1	SCREW (M10-1.50 X 25MM)	
3.	155-171	1	REDUCER (10S-06SF)	
4.	155-253	1	CONNECTOR (06S-02NF)	
5.	215-073	1	SENSOR SWITCH	
6.	105-047	4	LOCKNUT (3/8-NC)	
7.	303-705	1	FIREWALL	
8.	215-478	2	BUTT CONNECTOR (14-16 GA)	
9.	195-843	1	INJECTOR NOZZLE (CLDSTR)	INCL FERRULE AND NUT
	156-204	-	FERRULE (02T)	
	156-205	-	COMPRESSION NUT (02T)	
10.	156-272	1	TUBE CONNECTOR (02N-02T90,ORF)	INCL FERRULE AND NUT
	156-204	-	FERRULE (02T)	
	156-205	-	COMPRESSION NUT (02T)	
11.	195-841	1	VALVE/CANISTER BRACKET	INCL CAPLUG AND GASKET
	110-252	-	CAPLUG (3/4")	
	195-844	-	GASKET	
12.	115-365	AR	GROMMET (2-1/8", SOLD PER 1")	USE 1 @ 1.50"
13.	105-825	4	FLG LK BOLT (3/8-NC X 3/4")	
14.	156-018	AR	BULK TUBING (1/8", SOLD PER 1")	USE 1 @ 40"
15.	215-590	1	RING TERMINAL (3/8")	
16.	217-917	1	ROCKER SWTCH (DPDT) OFF-(ON)	REPLACES PLUG IN R.H. OPERATOR CONSOLE

FOOTNOTES

1. REFER TO INSTALLATION INSTRUCTIONS 051-252.
2. 8 OZ. ETHER CANISTER IS REQUIRED, WHICH WILL INCLUDE SEALS AND FOAM

DRILLING FLUID TRANSFER

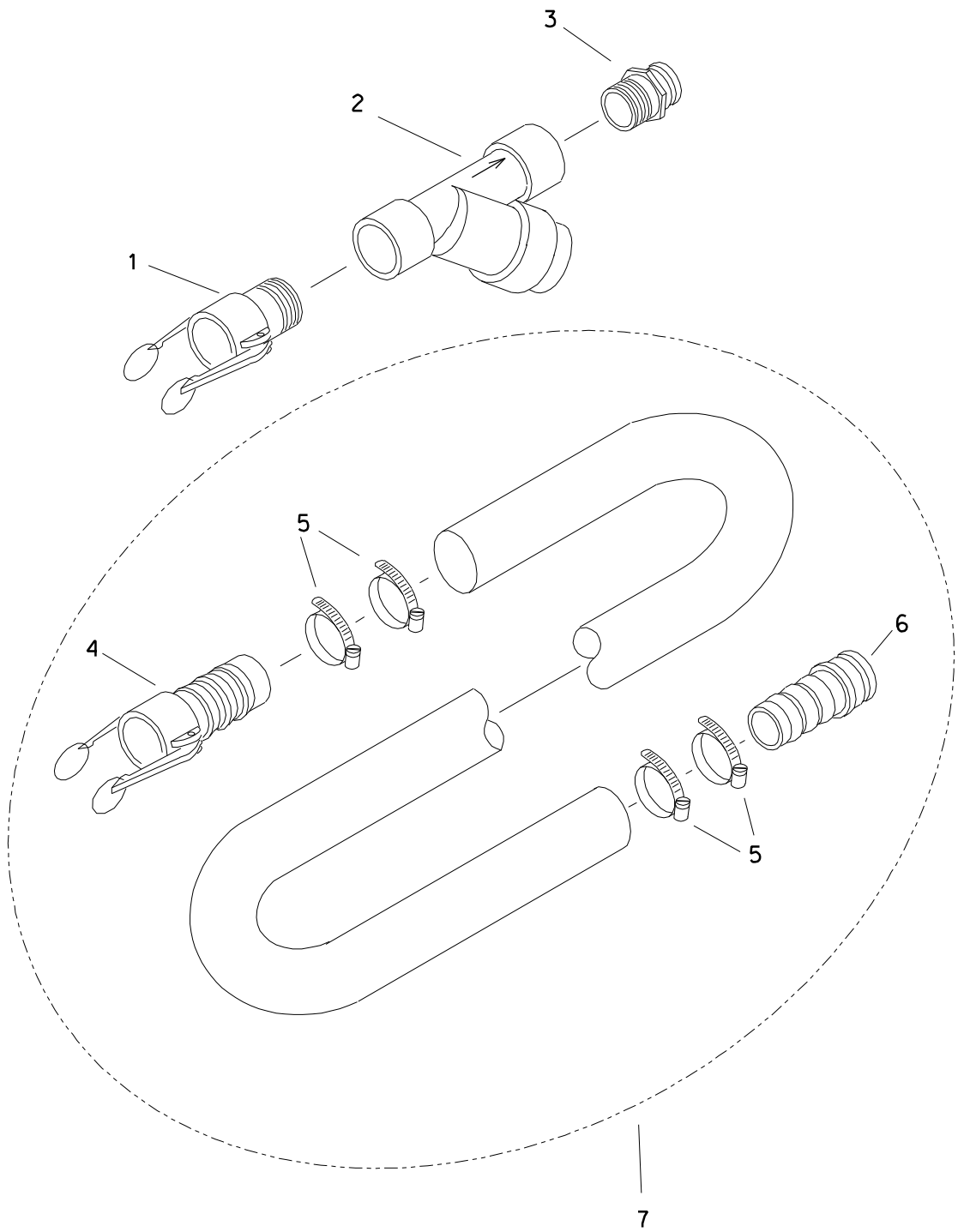

DRILLING FLUID TRANSFER

REF NO.	PART NUMBER	QTY	DESCRIPTION	REMARKS
	153-371		Y-STRAINER PARTS ASS'Y	INCL REF NO'S 1 - 3
1.	514-386	1	FHC BODY (3-1/2" FHC X 3"NPT)	
2.	159-439	1	Y-STRAINER (48NF)	
	159-490	-	STRAINER (4" X 9")	
	165-895	-	O-RING (END CAP)	
	111-083	-	END CAP	
	308-651	-	END CAP CLAMP	
3.	155-263	1	FHC ADAPTER (56-48N)	
4.	155-264	-	FHC BODY (56-48H)	USE TO REPAIR 153-358
5.	110-367	-	WORM CLAMP (3.250" TO 4.125")	USE TO REPAIR 153-358
6.	153-341	-	FHC ADAPTER (56-48H)	USE TO REPAIR 153-358
7.	153-358	-	TRANSFER HOSE (3" FHC, 50')	USE REF NO'S 4 - 6 TO REPAIR

FOOTNOTES

FLUID MIXING ACCESSORIES

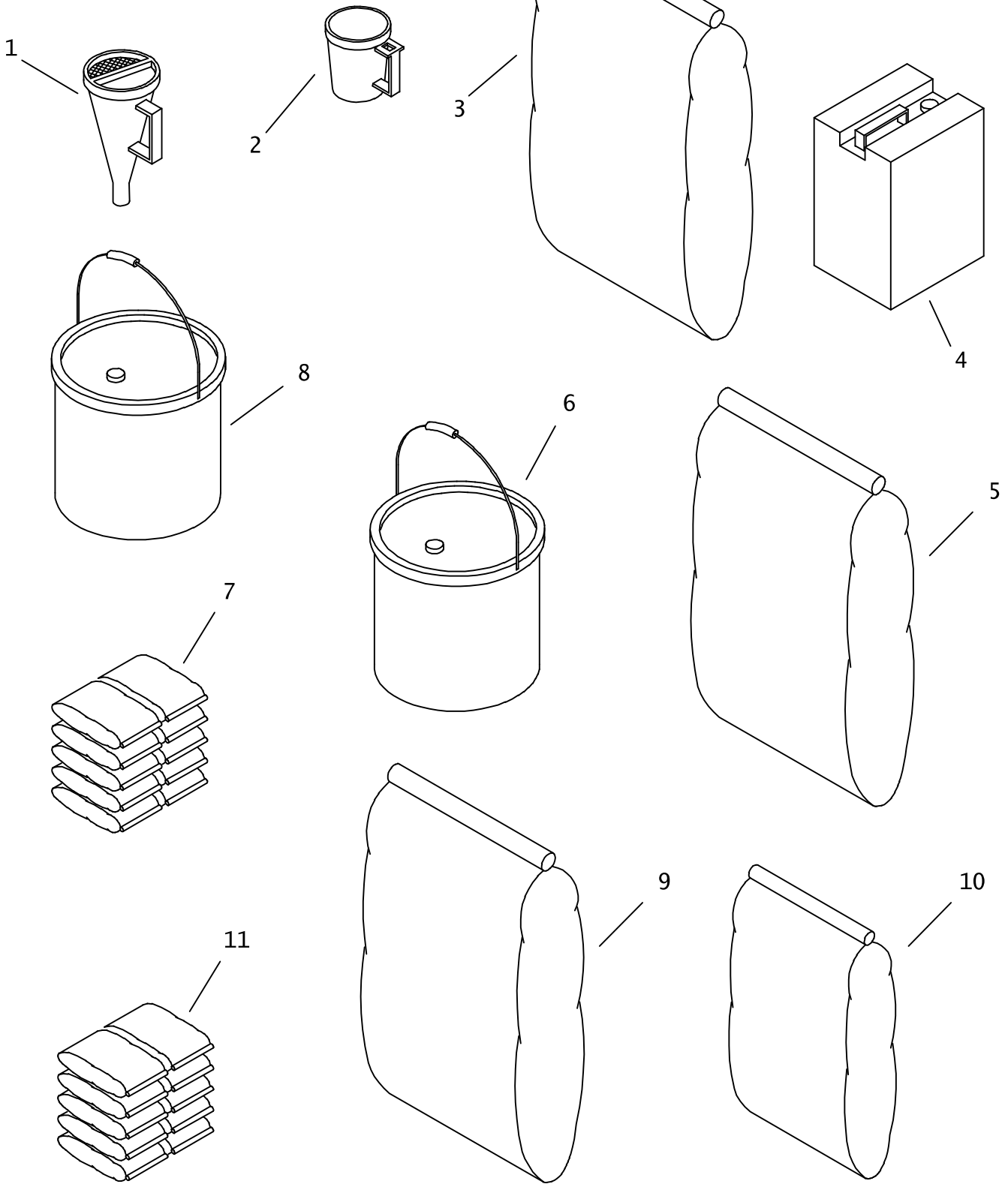

FLUID MIXING ACCESSORIES

REF NO.	PART NUMBER	QTY	DESCRIPTION	REMARKS
1.	259-195	1	VISCOSITY FUNNEL	
2.	259-196	1	VISCOSITY CUP	
3.	259-804	AR	BENTONITE, QUIK-GEL (50 LB)	
4.	259-805	AR	LIQUID POLYMER, EZ-MUD (5 GAL)	
5.	259-807	AR	BENTONITE, BORE-GEL (50 LB)	
6.	259-808	AR	VISCOSIFIER, LIQUI-TROL (5 GAL)	
7.	259-809	AR	POWDER POLYMER, QUIK-TROL (20 LB)	
8.	259-810	AR	WET AGENT, CON-DET (5 GAL)	
9.	259-821	AR	'PAC-R' FILTRATION CONTROL	
10.	259-822	AR	'BARAZAN D+' VISCOSIFIER	
11.	259-832	AR	'NO SAG' (20# BOX/10-2#BAGS)	

NOT SHOWN:

191-158	1	DRILLING FLUID TEST KIT
259-487	1	SHEAROMETER

FOOTNOTES:

NOTE:

HEATED HOSE KIT

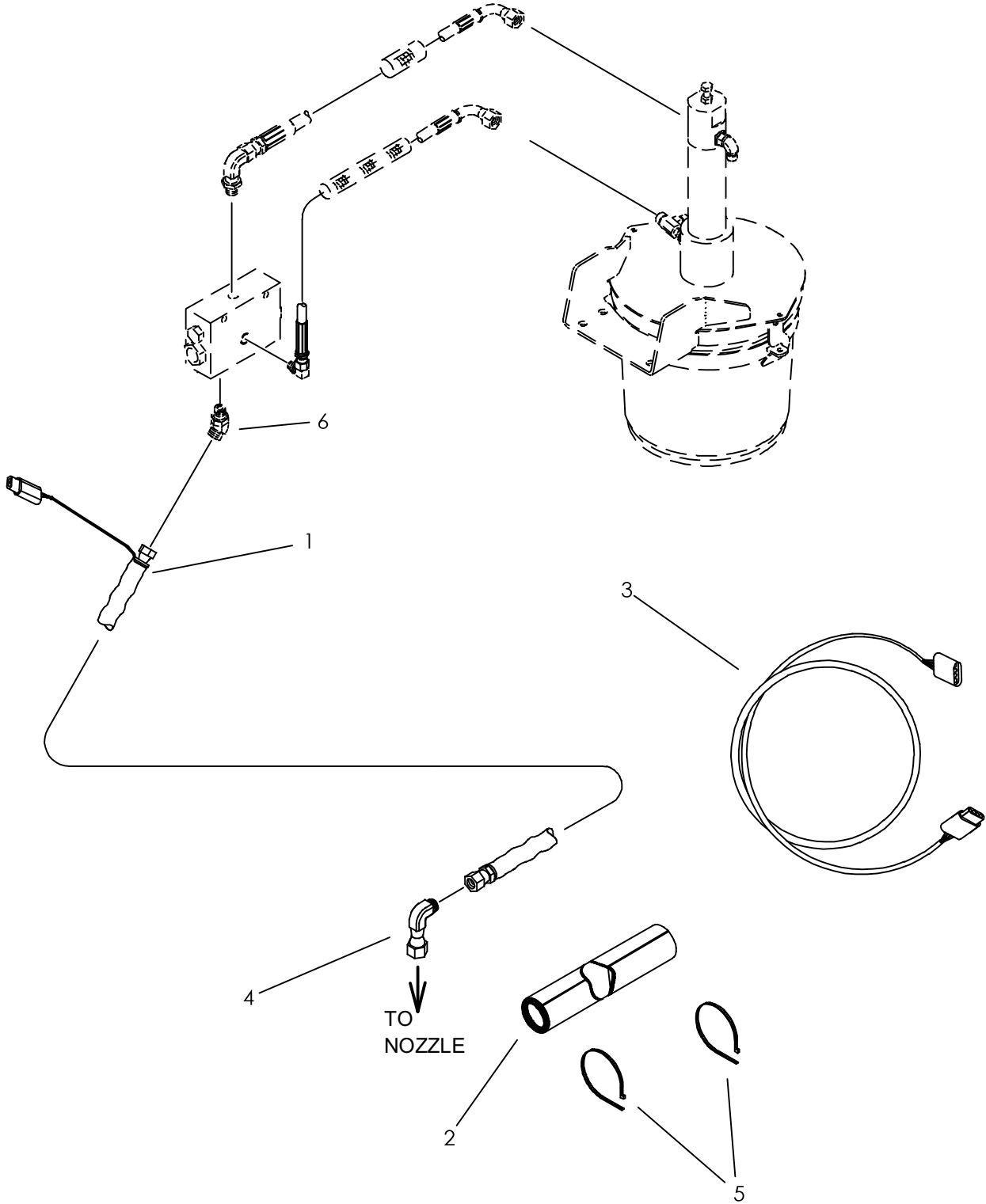

HEATED HOSE KIT

REF NO.	PART NUMBER	QTY	DESCRIPTION	REMARKS
	101-088		JT27M1 HEATED HOSE KIT	USE REF.'S 1, 2, 3, & 5
	101-089		HEATED HOSE KIT	USE REF.'S 1, 2, 4, & 5
1.	153-585	1	HOSE (060FX-18"-3000,SPCL)	
2.	117-549	1	INSULATOR (1" ID X 5.00")	
3.	214-843	1	GREASER JUMPER HARNESS	USED ON JT2720 MACH 1 ONLY
4.	154-228	1	UNION (060-060FX90)	USED ON JT1720 MACH 1 & JT4020 MACH 1 ONLY
5.	110-030	4	CABLE TIE (1/16" TO 4")	
6.	154-224	1	CONNECTOR (06S-06045)	

NOT SHOWN:

FOOTNOTES:

NOTE:

REFERE TO INSTALLATION INSTRUCTION 05I-29I.

WORKING LIGHT

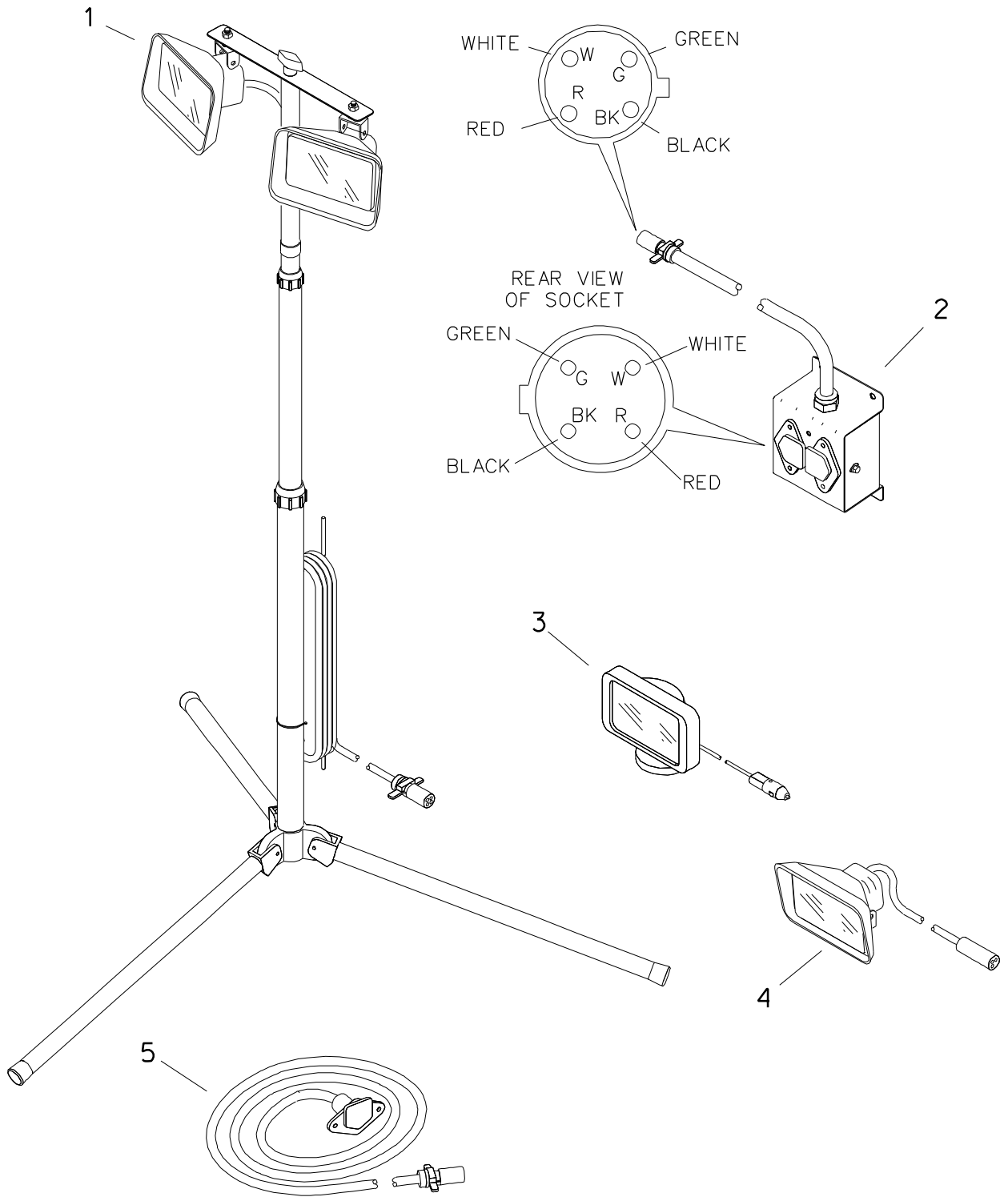

WORKING LIGHT

REF NO.	PART NUMBER	QTY	DESCRIPTION	REMARKS
1.	190-663	1	WORKING LIGHT CONVERSION KIT	INCL TRIPOD
	217-084	-	TRIPOD	
	217-094	1	DUAL LIGHT CABLE	
	217-080	2	WORKING LAMP (12V DC)	RECTANGULAR, MULTI-PURPOSE
	214-228	2	LIQUID-TIGHT FITTING	
	106-176	2	CONDUIT LOCKNUT (Ø8N)	
	110-373	1	BOLT-ON CLAMP (13/16")	
	106-162	1	FLG SCREW (M8-1.25 X 20mm)	
	106-386	1	FLG LOCKNUT (M8-1.25)	
	347-832	1	BRACKET (LIGHT KIT)	
	110-030	1	CABLE TIE (1/16" TO 4")	
	110-259	1	BOLT-ON CLAMP (.625")	
2.	190-664	1	LIGHT BOX KIT	
	347-833	1	LIGHT JUNCTION BOX	
	347-836	1	BACK PLATE	
	214-229	1	LIGHT HARNESS	JUNCTION BOX
	217-040	3	CONNECTOR (4-WAY, FM)	
	217-039	1	INDICATOR LIGHT (RED)	
	106-379	10	FLG LK SCREW (M6-1.00 X 20mm)	
	106-106	6	NUT (M6-1.00)	
	106-754	4	WELD NUT (M10-1.50)	
3.	217-098	1	WORK LAMP {12V DC, MAGNETIC}	
4.	190-665	1	LIGHT KIT (SINGLE)	
	217-080	1	WORKING LAMP (12V DC)	RECTANGULAR, MULTI-PURPOSE
	217-092	1	SINGLE LIGHT CABLE	
	214-228	1	LIQUID-TIGHT FITTING	
	106-176	1	CONDUIT LOCKNUT (Ø8N)	
5.	217-096	1	EXTENSION CABLE (30M {100'})	

FOOTNOTES

GROUNDING HARDWARE

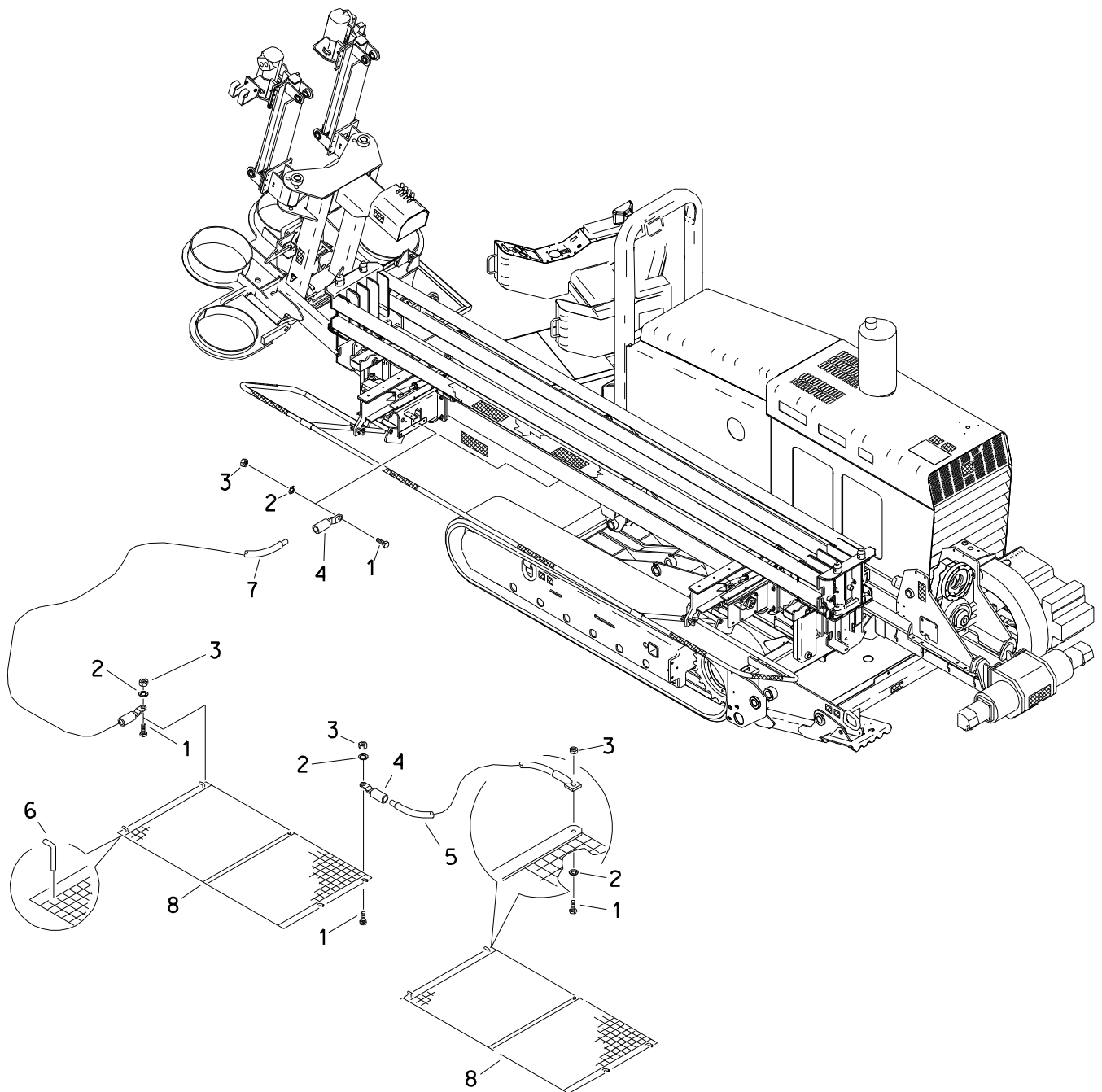

GROUNDING HARDWARE

REF NO.	PART NUMBER	QTY	DESCRIPTION	REMARKS
	100-074	-	STRIKE MAT KIT	INCL REF NO'S 1-8
1.	106-217	4	BOLT (1/4-NC X 1", SIL BRZ)	
2.	106-221	4	INT STAR WASHER (1/4", SIL BRZ)	
3.	106-455	4	LOCKNUT (1/4-NC, SIL BRZ)	
4.	215-771	2	GROUND RECEPTACLE (.3125" FM)	
5.	215-827	1	GROUND CABLE (6 GA X 6' M-EYE)	
6.	183-658	8	MAT STAKE	
7.	215-790	1	GROUND CABLE (6GA X 20' M-EYE)	
8.	215-824	2	GRID (6')	

FOOTNOTES

VANDAL COVERS

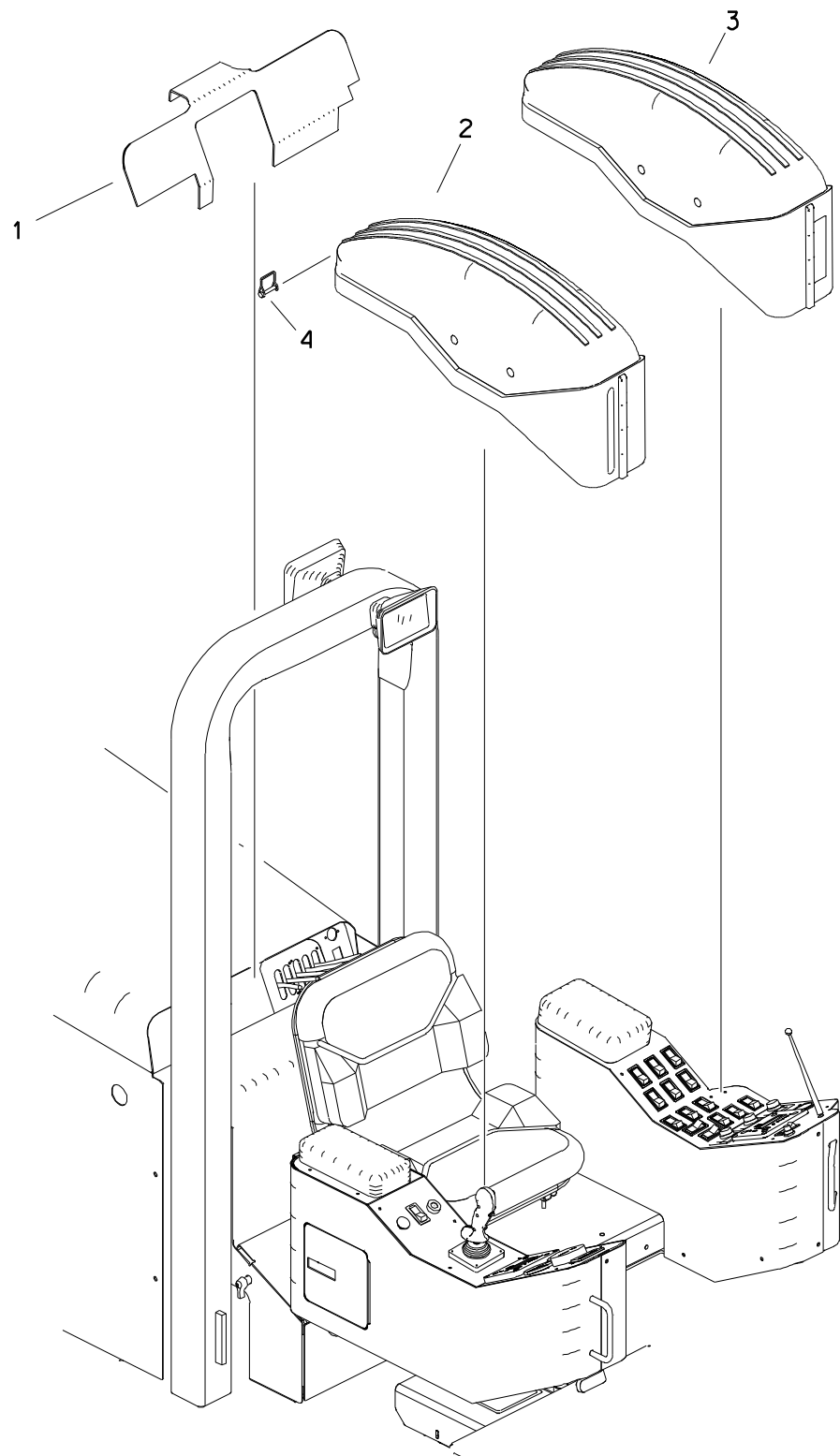

VANDAL COVERS

REF NO.	PART NUMBER	QTY	DESCRIPTION	REMARKS
	N/A		VANDAL KIT	
1.	310-961	1	GAUGE VANDAL COVER	
2.	310-960	1	RIGHT SIDE VANDAL COVER	
3.	315-790	1	LEFT SIDE VANDAL COVER	
4.	110-032	2	SNAPPER PIN (5/16" X 2-1/2")	

FOOTNOTES

TOOL BOX

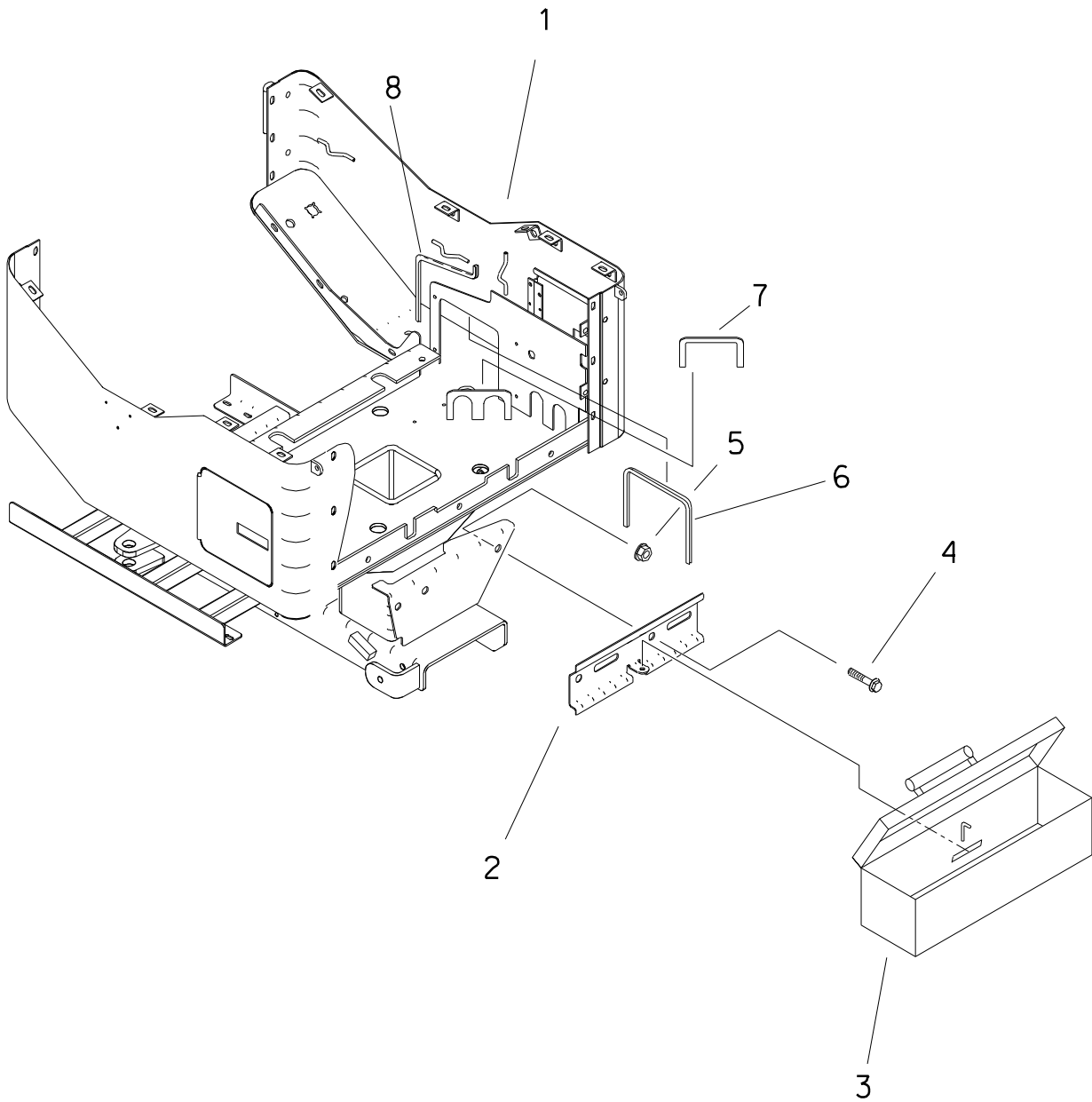

TOOL BOX

REF NO.	PART NUMBER	QTY	DESCRIPTION	REMARKS
1.	308-794	-	OPERATOR FRAME	
	313-778	-	PLATE	SEE FOOTNOTE 1.
2.	313-777	1	BRACKET	
3.	313-776	1	TOOL BOX	
4.	106-471	2	FLG SCREW (M16-2.00 X 30MM)	
5.	106-442	2	FLG LOCKNUT (M16-2.00,PRV TRQ)	
6.	116-789	AR	RUBBER EDGE TRIM 1/8" (FT)	USE 1 AT 18"
7.	116-789	AR	RUBBER EDGE TRIM 1/8" (FT)	USE 2 AT 10"
8.	116-789	AR	RUBBER EDGE TRIM 1/8" (FT)	USE 1 AT 19"

FOOTNOTES

1. EARLY MACHINES WILL REQUIRE THIS PART TO BE WELDED TO OPERATOR CONSOLE.

MISCELLANEOUS

SAE Bolt and Nut Torque Value Chart

Grade 5: UNC or UNF Thread

Size	Hex nut, or bolt tapped into hex nut, or d&t hole		Hex top deformed locknut		Flange nut, locknut, or bolt tapped into flange nut or d&t* hole	
	ft•lb	N•m	ft•lb	N•m	ft•lb	N•m
1/4	12	16	8	11	20	27
5/16	25	34	15	20	45	60
3/8	40	54	25	34	75	100
7/16	65	90	40	55	125	170
1/2	100	135	60	80	190	260
9/16	150	200	90	125	270	370
5/8	200	270	120	165	370	500
3/4	350	475	210	285	650	880
7/8	560	760	340	460	1250	1425
1	840	1140	500	680	1580	2145
1-1/8	1030	1400	320	840	1950	3645
1-1/4	1460	1980	880	1195	2760	3475

Grade 8: UNC or UNF Thread

Size	Hex nut, or bolt tapped into hex nut, or d&t hole		Hex top deformed locknut		Flange nut, locknut, or bolt tapped into flange nut or d&t* hole	
	ft•lb	N•m	ft•lb	N•m	ft•lb	N•m
1/4	14	19	10	14	24	33
5/16	30	40	18	25	50	70
3/8	55	73	35	50	90	125
7/16	85	115	50	70	140	190
1/2	130	175	80	110	220	300
9/16	190	260	110	150	310	420
5/8	260	355	160	245	430	585
3/4	450	610	270	365	750	1015
7/8	730	990	440	600	1210	1640
1	1090	1480	650	880	1320	2465
1-1/8	1550	2100	930	1260	2580	3500
1-1/4	2180	2955	1310	1780	3640	4935

*drilled and tapped

Metric Bolt and Cap Screw Torque Values

Size	Class 4.8				Class 8.8 and 9.8				Class 10.9				Class 12.9			
	Lubricated		Dry		Lubricated		Dry		Lubricated		Dry		Lubricated		Dry	
	N•m	ft•lb	N•m	ft•lb	N•m	ft•lb	N•m	ft•lb	N•m	ft•lb	N•m	ft•lb	N•m	ft•lb	N•m	ft•lb
M6	4.8	3.5	6	4.5	9	6.5	11	8.5	13	9.5	17	12	15	11.5	19	14.5
M8	12	8.5	15	11	22	16	28	20	32	24	40	30	37	28	47	35
M10	23	17	29	21	43	32	55	40	63	47	80	60	75	55	95	70
M12	40	29	50	37	75	55	95	70	110	80	140	105	130	95	165	120
M14	63	47	80	60	120	88	150	110	175	130	225	165	205	150	260	190
M16	100	73	125	92	190	140	240	175	275	200	350	225	320	240	400	300
M18	135	100	175	125	260	195	330	250	375	275	475	350	440	325	560	410
M20	190	140	240	180	375	275	475	350	530	400	675	500	625	460	800	580
M22	260	190	330	250	510	375	650	475	725	540	925	675	850	625	1075	800
M24	330	250	425	310	650	475	825	600	925	675	1150	850	1075	800	1350	1000
M27	490	360	625	450	950	700	1200	875	1350	1000	1700	1250	1600	1150	2000	1500
M30	675	490	850	625	1600	950	1650	1200	1850	1350	2300	1700	2150	1600	2700	2000
M33	900	675	1150	850	1750	1300	2200	1650	2500	1850	3150	2350	2900	2150	3700	2750
M36	1150	850	1450	1075	2250	1650	2850	2100	3200	2350	4050	3000	3750	2750	4750	3500

Do not use these values if a different torque value or tightening procedure is given for specific application. Torque values listed are for general use only. Check tightness of fasteners periodically.

Shear bolts are designed to fail under predetermined loads. Always replace shear bolts with identical property class fasteners.

Fasteners should be replaced with the same or higher property class. If higher property class fasteners are used, these should only be tightened to strength of original.

Make sure fastener threads are clean and that the threads are properly started. This will prevent them from cross threading or galling when tightened.

Tighten plastic insert or crimped type steel locknuts to approximately 50% of dry torque indicated on chart. Apply torque to the nut - not the bolt head. Tighten toothed or serrated type locknuts to full torque value.

LUBRICATED means coated with lubricant. DRY means plain or zinc plated without any type of lubricant.

Hydraulic Cylinder Bolt Torque Chart

Bolt Size (inch)	Bolt Part No.	Cylinder Repair Kit Part No.	Torque (ft•lb)	Torque (N•m)
1/2	106-096	190-165	90-100	120-135
5/8	106-097	190-166 & 190-169	180-200	245-270
3/4	106-098	190-167 & 190-170	290-325	395-440
7/8	106-122	190-172 & 190-174	410-640	550-625
1	106-145	190-175 & 190-189	630-700	855-950
1-1/8	106-146	190-177	770-850	1045-1170

As a general rule:

- 1/2-inch bolts are used in cylinders with 1-inch rods
- 5/8-inch bolts are used in cylinders with 1 1/4-inch rods
- 3/4-inch bolts are used in cylinders with 1 1/2-inch rods
- 7/8-inch bolts are used in cylinders with 1 3/4-inch rods
- 1-inch bolts are used in cylinders with 2-inch rods (one with 1 3/4-inch)
- 1-1/8-inch bolts are used in cylinders with 2-1/4-inch rods

IMPORTANT: Do not reuse cylinder piston bolts when rebuilding a hydraulic cylinder. Each cylinder repair kit contains a new bolt. Use it. Lubricate lightly and torque to value shown on chart.

SAE & ORS Hydraulic Fitting Replacement O-Ring Chart

Fraction Size	Dash Size	SAE (Port Seal O-Ring)		ORS (Face Seal O-Ring)	
		Thread Size	O-Ring P/N	Thread Size	O-Ring P/N
1/16	1	NA	NA	NA	NA
1/8	2	5/16 - 24	NA	NA	NA
3/16	3	3/8 - 24	NA	NA	NA
1/4	4	7/16 - 20	155-760	9/16 - 18	157-037
5/16	5	1/2 - 20	NA	NA	NA
3/8	6	9/16 - 18	155-705	11/16 - 16	157-038
1/2	8	3/4 - 16	155-706	13/16 - 16	157-039
5/8	10	7/8 - 14	155-707	1 - 14	157-040
3/4	12	1-1/16 - 12	155-709	1-3/16 - 12	157-017
7/8	14	1-3/16 - 12	155-747	NA	NA
1	16	1-5/16 - 12	155-748	1-7/16 - 12	155-714
1-1/4	20	1-5/8 - 12	155-702	1-11/16 - 12	NA
1-1/2	24	1-7/8 - 12	157-001	2 - 12	NA
2	32	2-1/2 - 12	NA	NA	NA
2-1/2	40	3 - 12	NA	NA	NA
3	48	3-1/2 - 12	NA	NA	NA

Thread size indicates the diameter of the threaded area in fractions of an inch and number of threads per inch.

NA = not a current CMW part numbered o-ring, or dash size does not occur in current CMW applications

SAE = straight thread fitting that seals by sandwiching a hard o-ring between a shoulder on the male part and an angular surface at the mouth of the female port.

ORS = o-ring face seal; a type of fitting that seals by compressing a hard, captive o-ring between two flat parallel faces, one grooved for the o-ring and the other plain to act as the sealing surface

JT4020 All Terrain

Related Publications

Component	Ass'y	P/N
Model:		
JT4020 All Terrain . Parts Manual		053-092
JT4020 All Terrain . Operators Manual		054-082
JT4020 All Terrain . Repair Guide (Service Manual)		N/A
JT4020 All Terrain . Supplementary Maint Guide - Trenchless		055-485
JT4020 All Terrain . Special Tools Guide		052-901
Engine:		
John Deere Parts Manual - 6068TF250	194-083	053-061
John Deere Operators Manual - 6068TF250		054-049
John Deere Service (Shop) Manual - 6068TF250		054-049

Filters

Engine:		
Air Filter Parts Ass'y		159-373
Element (primary)		194-827
Element (secondary)		194-828
Oil Filter Element (spin-on) - John Deere		194-815
Fuel Filter Element (water trap, spin-on) - John Deere		194-816
Fuel Strainer (04H) In Fuel Tank.....		156-268
Hydraulic:		
Oil Filter Element (_ _ / _ -UNF, spin-on) – Charge Remote		149-939
Element (_ _ / _ -UNF, spin-on, Micron 10, Replacement) - Return		157-486

Optional Kits

O-ring Repair Kit - FLG, ORS & SAE (15 different O-rings)	190-051
O-ring Repair Kit - Field Service (46 different O-rings)	190-052



Parts Manual Change Request

(Please print clearly)

Date: _____ Dealer No. (required): _____

Your Name: _____ Position: _____

Phone: _____ Fax: _____ E-mail: _____

Publication Information:

Parts Manual No.: _____ - _____ Model: _____

Illustration Part No.:	Manual Page No.:
1. _____ - _____	1. _____
2. _____ - _____	2. _____
3. _____ - _____	3. _____

Nature of Change Request:

- Text
- Graphics
- Missing Information

Describe change requested (if possible, include copy of publication page with changes marked.):

Please fax completed form to
Parts Manual Department (580) 572-3525

Thank you for taking the time to submit this request. We will contact you if further information is needed to process your request.

**A Note To
Ditch Witch
Equipment Owners:**

If your equipment was purchased through a Ditch Witch dealer, there is no need to read further.

However, if you purchased from any other source, please fill out the form on the reverse side and return it to us.

This will enable you to receive updates on this equipment as well as information on new products of interest.

Thanks for using Ditch Witch equipment.

(Please Fold Along This Line And Seal At Bottom With Tape)



**NO POSTAGE
NECESSARY
IF MAILED
IN THE
UNITED STATES**

BUSINESS REPLY MAIL
FIRST CLASS PERMIT NO 23 PERRY OKLAHOMA

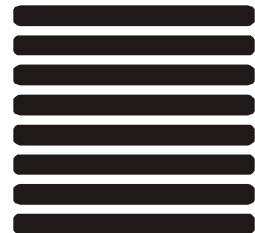

POSTAGE WILL BE PAID BY

**The Charles Machine Works, Inc.
P.O. Box 66
Perry, Oklahoma 73077-9989**



Ditch Witch® Registration Card

Please Type or Print All Information

Purchaser's Company Name

Attention

Street Address or P.O. Box

City County

State Zip Nation

()

Phone Number With Area Code

Model S rial Number

Attachments/Accessories Serial Numbers

Attachments/Accessories Serial Numbers

Attachments/Accessories Serial Numbers

Name of Ditch Witch Dealership

Your Signature